

WIRELESS STATION A510

TECHNICAL HANDBOOK - MODIFICATION INSTRUCTION

Receiver netting

SUMMARY

1. This modification has been introduced in order to improve the netting of the receiver by reducing the spurious responses. Additional bias is applied to the detector diode during netting.

Time required to perform modification - 1.1/2 man-hours.

2. Items affected:-

Wireless station A510
Receiver, Serial Nos B1 - B150.

3. Action required by:-

(a) Units affected :-

(i) Submit AF G1045 to REME requesting this modification to be carried out.

(b) Units authorized to carry out field or base repairs:-

- (i) Indent for stores.
- (ii) Carry out modification as detailed.

4. Priority: Group 'B' (ACI 407/58 refers).

5. Stores required:-

<u>VAOS Sect</u>	<u>Part No</u>	<u>Designation</u>	<u>Qty per eqpt</u>
Z	AZ 1756	Capacitors, silvered ceramic, tubular, 12pF ±5%, 500V d.c. wkg	2
Z	AZ 1761	Capacitors, silvered ceramic, tubular 4.7pF ±20%, 500V d.c. wkg	1
Z	Z 222130	Resistors, composition, grade 2, insulated, 1/4W, 10kΩ ±10%	1

Stores will be demanded through the normal Ordnance channels. Authority for demand (to be quoted on all indents) T/W/FZ/4.

DETAIL (See Fig 1)

6. (a) Remove the receiver from its case as follows:-

- (i) Remove the hexagon nuts and bolts from the corners of the panel.
- (ii) Holding the set upright with one hand, withdraw the unit from its case by means of the carrying handle, taking care not to damage the sealing gasket.

Note: The receiver will be opened only in dry conditions and under cover. Apparatus, seal testing, (See Tels M 630 - M 639) must be available for subsequent re-sealing operations.

- (b) Locate resistor R17 ($47k\Omega$ $1/2W$) and unsolder and lift that end of it which is connected to the tag marked 'C32'.
- (c) Cover the body of one of the Capacitors, Z/ZA 1756 supplied, with $3/8$ in. of 10 mm P.V.C. sleeving and solder this capacitor between pin 1 (green spot) of the inductor L10 and the tag marked 'R17'. This capacitor becomes 'C40'.
- (d) Solder the floating end of R17 (disconnected at (b)) back on to the tag marked 'C32'.
- (e) Unsolder and remove the wire lead connecting pin 2 of V5 to the tag marked 'R7'.
- (f) Solder the other Capacitor Z/ZA 1756 in circuit between the two points from which the wire was removed at 7(e), ie between pin 2 of V5 and the tag marked 'R7'. This capacitor becomes 'C41'.
- (g) Solder the resistor Z/Z 222130, supplied, between the tag marked 'R7' and the centre spigot of the valve holder V4. This resistor becomes 'R21'.
- (h) Connect the tag marked 'R7' to pin 4 of the valve holder V4 using 20 s.w.g. tinned copper wire insulated by $1.1/2$ mm yellow P.V.C. sleeving.
- (j) Unsolder and lift the wire lead which connects at the tag marked 'C25' (This lead joins tag 'C25' and pin 4 of the second i.f. transformer, TR2). Also, unsolder and lift the earth end of resistor R14.
- (k) Connect the Capacitor Z/AZ 1761, $4.7pF$, supplied, between pin 4 of the valve-holder V4 (covering this lead of the capacitor with $1.1/2$ mm yellow P.V.C. sleeving) and pin 1 (red spot) of TR2. This capacitor becomes 'C42'.
- (l) Resolder the connections removed at (j) to their respective tags.
- (m) Strike through the figure 2 on the receiver modification record plate.
- (n) Connect the receiver to its power supplies and check the netting and the general functioning of the set.
- (o) Replace the receiver in its case together with a fresh desiccator and carry out the complete drying and resealing procedure which is detailed at paras 7(q)(i) to (q)(ix) of Tels F 567, Mod Instr No 1, but substituting the word 'receiver' for 'transmitter' where appropriate.

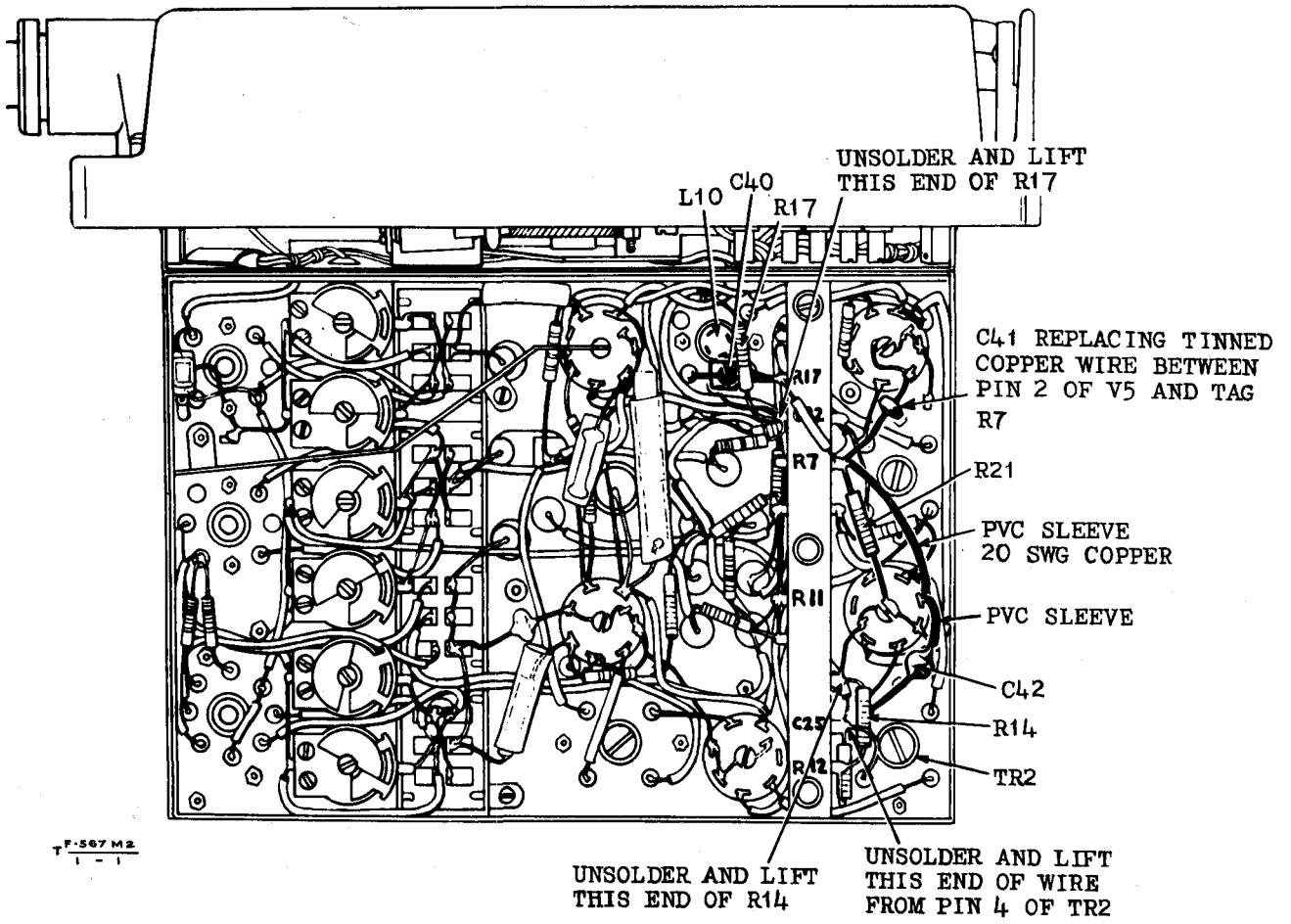

Fig 1 - Underside view of receiver chassis

Encl 3 to
57/Maint/7216

END

WIRELESS STATION A510.

TECHNICAL HANDBOOK - MODIFICATION INSTRUCTION

Increasing keying speed

SUMMARY

1. Equipments above serial number B150 have been modified in production to have a transmitter sidetone oscillator keying speed of 20 w.p.m. This regulation gives details of the changes necessary to increase the keying speed of the earlier equipments from 8 to 20 w.p.m.

Time required to perform modification: 1 man-hour.

2. Items affected:-

Wireless station, A510.

Transmitter, Serial Nos B1 - B150

3. Action required by:-

(a) Units affected:-

(i) Submit AF G1045 to REME requesting this modification to be carried out.

(b) Units authorized to carry out field or base repairs:-

(i) Indent for stores.

(ii) Carry out modification as detailed

4. Priority: Group 'B' (ACI 407/58 refers).

5. Stores required:-

<u>VAOS.</u> <u>Section</u>	<u>Part No</u>	<u>Designation</u>	<u>Qty</u> <u>per eqpt</u>
Z	Z 115626	Capacitors, paper, ins, tub, 0.005 μ F \pm 25%, 350V d.c. wkg, No 2	2
Z	Z 223079	Resistors, composition, grade 2, insulated 1/4W, 220k Ω \pm 10%	1
	1.1/2 mm P.V.C. sleeving (to be obtained locally)		As required

Stores will be demanded through the normal Ordnance channels. (Serial Nos of sets to be quoted on all demands).

Authority for demand (to be quoted on all indents) - T/W/FZ/3

6. Stores removed:-

Capacitors C109 (0.01 μ F) and C111 (0.005 μ F).

These items to be disposed of locally.

DETAIL

7. (a) Remove the transmitter from its case as follows; noting that the transmitter will only be opened in dry conditions and under cover. Apparatus, seal testing (see Tels M 630-639) must be available for subsequent re-sealing operations.
- (i) Remove the four hexagon nuts and bolts from the corners of the panel.
 - (ii) Holding the set upright with one hand withdraw the unit from its case by means of the carrying handle.
- (b) Locate capacitor C109 (0.001 μ F) (see Fig 1).
- (c) Replace C109 by one of the 0.005 μ F capacitors (Z/Z 115626) provided, connecting one end of the new capacitor to the earth point directly below the spacing pillar and the other end to the top tag diagonally opposite to this earth point. Discard the 0.001 μ F capacitor.
- (d) Locate and remove capacitor C111 (0.005 μ F), which is connected between pin 2 of the valve holder V6 and the terminal plate, and lies underneath capacitor C127 (0.01 μ F) (see Fig 2). Discard the capacitor.
- (e) Place the other capacitor Z/Z 115626 supplied, into the space vacated by C111 and connect it between pin 3 of the valve holder V6 and the earthed spigot of the valve holder V7, after cutting each of the leads of the new capacitor to a suitable length and insulating it with 1.1/2 mm yellow sleeving. This new capacitor becomes 'C129' (see Fig 3).
- (f) Referring to Fig 4, locate and remove the lead which joins the centre tag of the 3-point key socket SK3 to pin 7 of the switch SWE. Solder the resistor (220k Ω , Z/Z 223079) supplied, between the same two points ie so that it takes the place of the lead removed. The new resistor becomes R117.
- (g) Strike out the figure '1' on both transmitter and receiver modification record plates.
- (h) Check the sidetone oscillator keying speed, and the transmitter generally, for correct operation.
- (j) Replace the transmitter in its case together with a fresh desiccator and carry out complete drying and resealing procedure detailed in Tels F 567 Mod Instr No 1 sub-para 7(g)(i) to (ix).
- (k) Repeat the detail at (h).

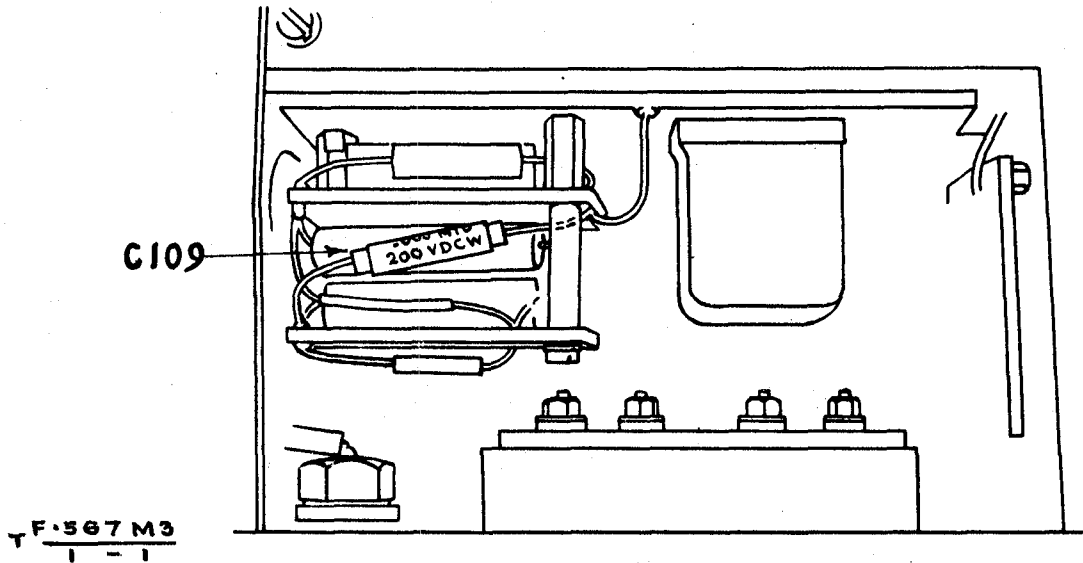

Fig 1 - Location of C109

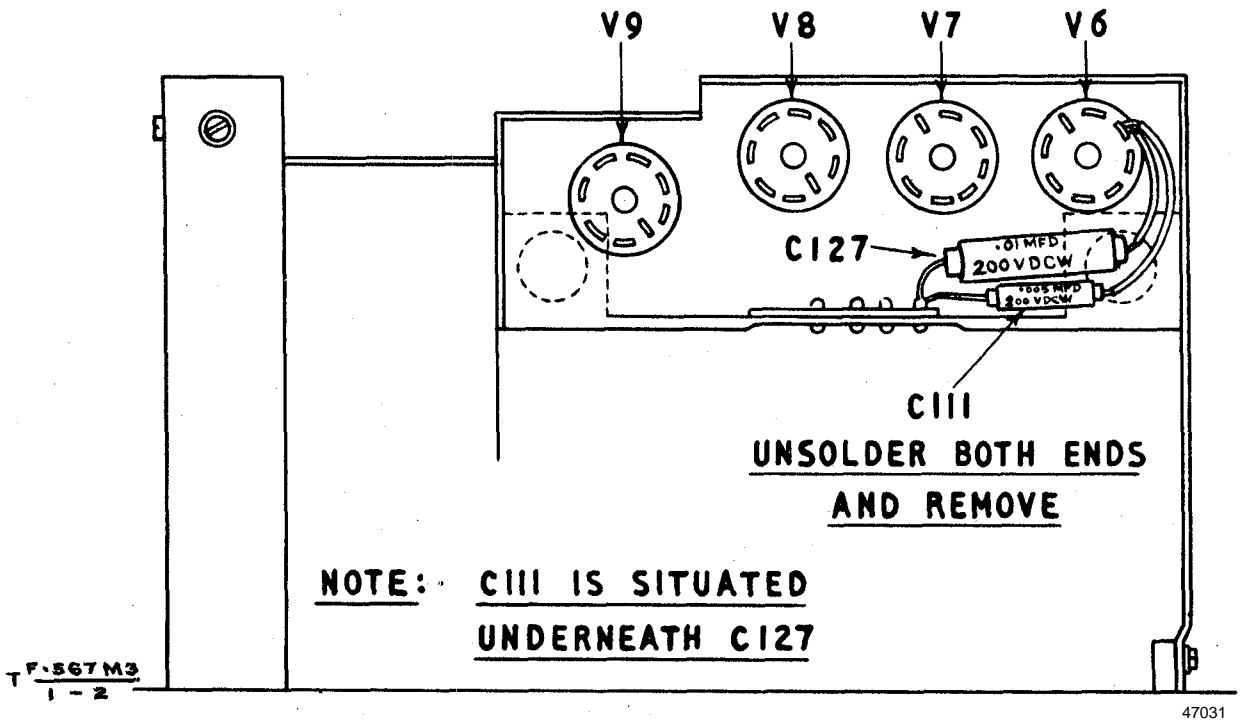

Fig 2 - Location of C111 and C127

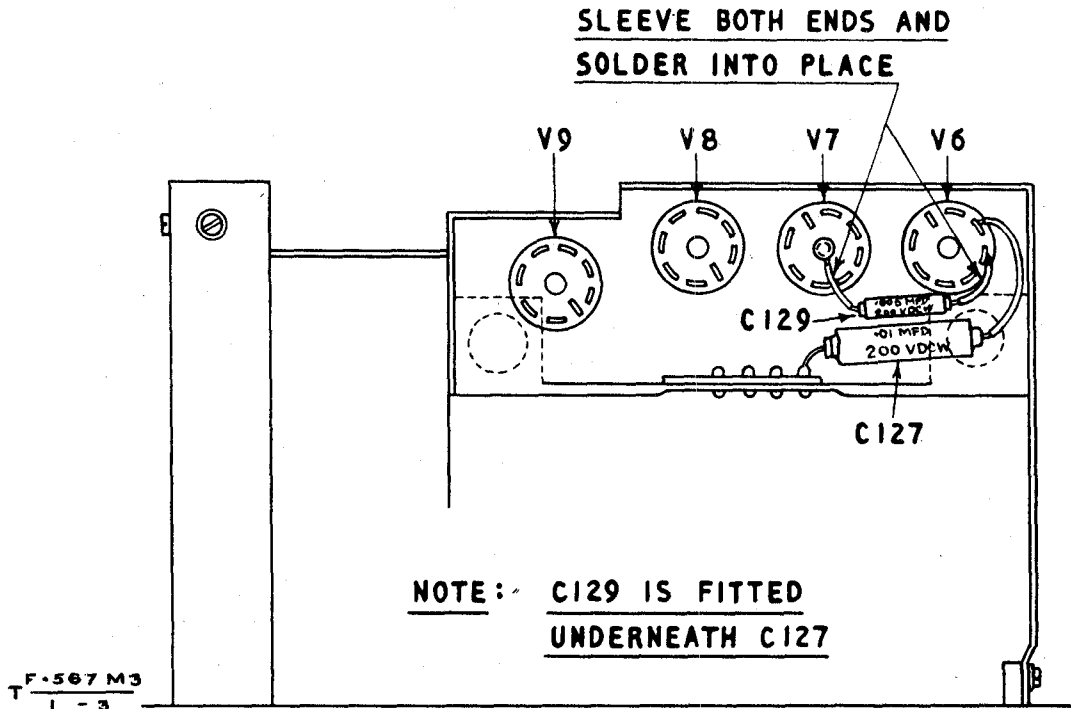

Fig 3 - Capacitor C129 in position

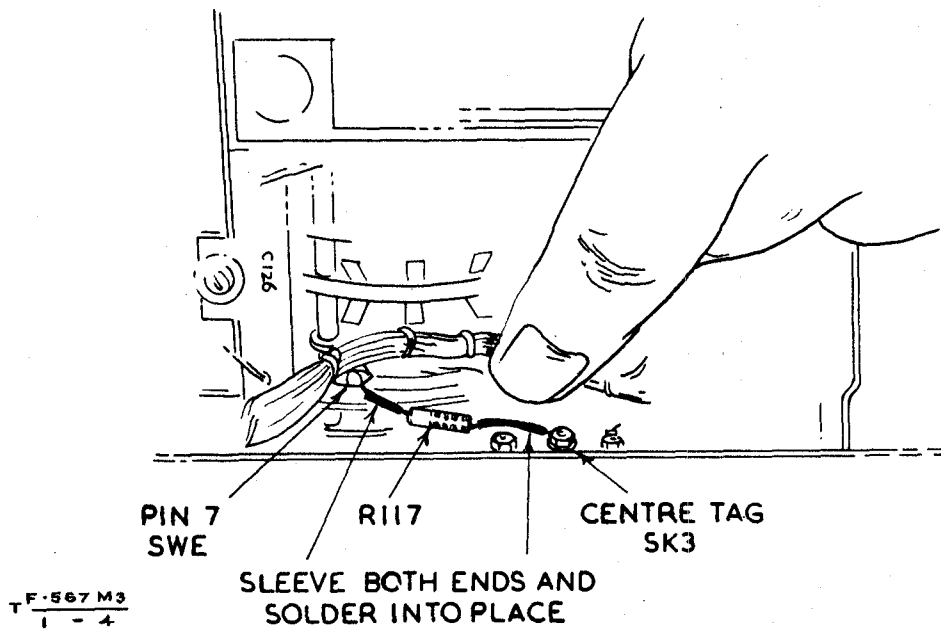

Fig 4 - Resistor R117 in position

WIRELESS STATION A510TECHNICAL HANDBOOK - MODIFICATION INSTRUCTIONReplacement of wave change switch index plateSUMMARY

1. The clicker plate and spindle assembly of the wavechange switch fitted to Wireless station A510 (W.S.A510) receivers of serial Nos below B401 is designed for use with the original flexible index plate. The index plate provided as a maintenance spare for the W.S.A510, however, is of steel, case-hardened and non-flexible, and cannot be used with the assembly mentioned. When the index plate of receivers of serial Nos B1 - B400 needs to be replaced for the first time it will also be necessary to replace the existing clicker plate and spindle assembly by the maintenance item provided. The spindle of the new assembly is fitted with a yoke to which is attached a flexible crescent-shaped leaf having a hole to accommodate a 1/8 in. diameter steel ball. This Regulation gives the necessary fitting detail.

Estimated time required to carry out this modification: 1 man-hour.

2. Items affected:-

Wireless Station A510
Receiver - Serial Nos B1 - B400

3. Action required by:-(a) Units authorized to carry out field or base repairs:-

- (i) Demand stores from Ordnance when the wave change switch index plate requires replacement.
- (ii) Carry out the detail of this instruction.

4. Priority: Group 'C' (ACI 407/58 refers).5. Stores required:-

<u>VAOS, Section</u>	<u>Part No</u>	<u>Designation</u>	<u>Qty per eqpt</u>
Z1	TSE(W)8 - 700	Clicker plate and spindle assembly	1
Z2	TSE(W)8 - 26	Plates, index, wave change switch	1
LV6	MF7/BG-418-1	Balls, steel, 1/8 in. diameter	1

Stores to be demanded through the normal Ordnance channels as replacement items.

DETAIL

6. (a) Remove the receiver from its case as follows, noting that the receiver will only be opened in dry conditions and under cover. Apparatus, seal testing (see Tels M 630-639) must be available for subsequent resealing operations.

- (i) Remove the hexagon nuts and bolts from the corners of the panel.
- (ii) Holding the set upright with one hand, withdraw the unit from its case by means of the carrying handle, taking care not to damage the sealing gasket.

- (b) Remove the top cover and silica gel containers from the chassis.
- (c) Remove the two No 6 BA screws securing the front panel to the chassis assembly.
- (d) Turn the FREQUENCY knob fully clockwise, ie capacitor plates fully meshed.
- (e) Turn the FREQUENCY BAND switch fully anti-clockwise until the spindle disengages from the double-start nut as the lower edge of the front panel is eased away from the chassis. If the double start nut will not disengage, remove the screw from the centre of the knob and lift the knob to clear the panel stop to obtain more movement.
- (f) Remove the FREQUENCY BAND knob.
- (g) Remove the existing index plate and spindle assembly and fit the new index plate; using the packing washer provided to level the plate, and the two screws to locate it.
- (h) Fit the new shaft together with the Ball, steel, 1/8 in. Replace and secure the FREQUENCY BAND knob.
- (j) Close the front panel up to the chassis and re-engage the switch spindle with the double start nut taking care that the nut and the switch spindle are in the same relative positions, to avoid a 180 degree error in switching.
- (k) Replace the two No 6 BA screws to secure the front panel to the chassis.
- (l) Carry out a functional check of the receiver.
- (m) Strike through the figure 3 on the modification record plate.
- (n) Replace the top cover of the receiver, fit a fresh silica gel desiccator and replace the set in its case.
- (o) Carry out complete drying and resealing procedure as given at para 7(q) of Tels F 567 Mod Instr No 1
- (p) Finally, repeat the functional check.

WIRELESS STATION A510

TECHNICAL HANDBOOK - MODIFICATION INSTRUCTION

Replacement of Cone, lock, and Covers, cable entry

SUMMARY

1. In order to provide a more reliable sealing and to lessen the risk of damage during repairs, new types of Cone, lock, and Covers, cable entry, have been fitted to the interconnecting cables of transmitters and receivers of the Wireless station A510 (W.S.A510). The Cone, lock, has been changed on both cables on transmitters and receivers of serial numbers above B199. The Covers, cable entry, have been changed on transmitters of serial numbers B501 onwards, and on receivers of serial numbers B650 onwards. This regulation details action to be carried out on unmodified equipments.

Estimated time required to complete this modification: 4 man-hours per complete equipment.

2. Items affected:-

Wireless station A510

Transmitter - Serial Nos B1 - B199 for Cone, lock, modification.
Serial Nos B1 - B500 for Covers, cable entry, modification.

Receiver - Serial Nos B1 - B199 for Cone, lock, modification.
Serial Nos B1 - B649 for Covers, cable entry, modification.

3. Action required by:-

(a) Units affected:-

(i) Submit AF G1045 to REME requesting this modification to be carried out when the set is otherwise in need of repair or is to be inspected.

(b) Units authorised to carry out field or base repairs:-

(i) Demand stores from Ordnance after checking the requirement as at para 2.

(ii) Carry out the detail of this instruction on all equipments undergoing repair, inspection or overhaul.

4. Priority: Group 'B' (ACI 407/58 refers).

5. Stores required:-

<u>VAOS</u> <u>Section</u>	<u>Part No</u>	<u>Designation</u>	<u>Qty per</u> <u>equip</u>
Z1	TSE(W)8 - 242	Cone, lock	2
Z1	TSE(W)8 - 246	Covers, cable entry	1 or 2
		Sleeving, PVC, yellow, 3 mm (to be provided locally)	As required

Stores to be demanded through the normal Ordnance channels as replacement items.

6. Stores removed:-

<u>Description</u>	<u>Qty per equip</u>
Cone, lock (original type)	As applicable
Covers, cable entry (original type)	As applicable

These stores to be disposed of locally.

DETAIL

7. (a) Remove the unit (transmitter or receiver as applicable) from its case. This is to be done in the driest possible conditions and under cover, care being taken not to damage the sealing gasket as the set is hermetically sealed. Apparatus, seal testing (see Tels M 630 - 639) must be available for the subsequent resealing operation.
- (b) Lubricate the outer sheath of the cable with glycerine or french chalk, and unscrew the gland nut.
- (c) Remove and retain the four screws which secure the Covers, cable entry, to the chassis of the unit. Lift the cover.
- (d) Unsolder the cable connections at the set end after having first identified them for replacement purposes. Remove the cable from the unit.
- (e) Slide the Cover, cable entry, from the cable.
- (f) Remove the original type of Cone, lock.
- (g) Place the new Cone, lock, in position and spread the cable braid as evenly as possible. Trim if necessary.
- (h) Replace the Covers, cable entry, on the cable, substituting the new replacement if the item removed at (e) was of the old type.
- (j) Resolder the leads disconnected at (d) to their appropriate points after having first covered the end of each lead with a 1/2 in. length of Sleeving, PVC, yellow.
- (k) Push the excess cable down through the neck of the Cover, cable entry. Tighten the gland nut, lubricating it with glycerine or french chalk as necessary.
- (l) Place the Covers, cable entry, over its fixing holes on the unit and secure with the four screws removed at (c).
- (m) Strike through figures on the unit modification record plate of the transmitter and/or receiver as necessary according to the following table:-

	Change of Cone, lock	Change of Covers, cable entry
Transmitter	2	3
Receiver	4	5

- (n) Replace each unit in its case and carry out the sealing procedure described at para 7(q) of Tels F 567 Mod Instr No 1.
- (p) Carry out a complete functional test on the transmitter and receiver.

END

WIRELESS STATION A510

TECHNICAL HANDBOOK - MODIFICATION INSTRUCTION

Drive shaft worm of receiver tuning control

SUMMARY

1. To overcome backlash in the receiver tuning control of the Wireless station A510 (W.S. A510), receivers of serial numbers B650 onwards have been fitted with an improved type of worm drive shaft assembly. The new assembly directly replaces the original, the main difference being the inclusion of Springs, drive shaft and worm. The spring, which is recessed into one end of the Worm drive, shaft assembly, loads a 1/8 in. steel ball, and acts as an additional anti-backlash measure. This regulation details the action to be taken on unmodified equipments.

Estimated time required to complete this modification: 2 man-hours.

2. Items affected:-

Wireless station A510

Receivers - Serial Nos B1 - B649.

3. Action required by:-

(a) Units affected:-

(i) Submit AF G1045 to REME requesting this instruction to be carried out.

(b) Units authorized to carry out field or base repairs:-

- (i) Demand stores from Ordnance.
- (ii) Carry out the detail of this instruction on W.S.A510 receivers undergoing repair, overhaul or inspection.

4. Priority: Group 'B' (ACI 407/58 refers).

5. Stores required:-

<u>VAOS, Section</u>	<u>Part No</u>	<u>Designation</u>	<u>Qty per eqpt</u>
Z1	TSE(W)8-47	Worm drive, shaft assembly	1

This store to be demanded through the normal Ordnance channels as a replacement item.

DETAIL

6. (a) Remove the receiver from its case. This is to be done in the driest possible conditions and under cover, care being taken not to damage the sealing gasket. Apparatus, seal testing (see Tels M 630-639) must be available for the subsequent resealing operation.

- (b) Remove the top cover and silica gel containers from the chassis.
- (c) Remove the two No 6 BA screws which secure the front panel to the chassis.
- (d) Turn the FREQUENCY control knob fully clockwise, ie capacitor plates fully meshed.
- (e) Turn the FREQUENCY BAND knob fully anti-clockwise so that, as the front panel is eased away from the chassis, the double-start nut on the spindle of the knob can be disengaged from the switch spindle. If the nut will not disengage remove the screw from the centre of the knob and withdraw the knob slightly so that it can over-ride the front panel projection, which acts as a stop, and thus be moved further.
- (f) Put a short length of No 16 gauge wire into one of the small holes at the side of the spring-loaded split gear on the capacitor shaft to allow the spring loading to be retained when the worm drive is disengaged.
- (g) Remove the panel hinge screw, plain washer and spring washer from the volume control end of the front panel and ease that end of the panel away from the chassis. Slide the panel sideways to disengage the pivot screw of the worm drive shaft (this also acts as a panel hinge screw) from the chassis. The front panel will now be free of the chassis except for the connecting wires and care must be taken not to break or strain these in subsequent operations.
- (h) Put a $1/4$ in. or $5/16$ in. length of No 16 gauge wire into one of the small holes in the side of the split gear which drives the tuning dials. This wire is to retain the existing spring loading of the gear while the worm drive shaft is being changed, and must be short enough not to impede the motion of the gear when the small hole is covered by the plate which supports the gear.
- (j) Remove the locking nut and pivot screw of the worm drive shaft. Remove the shaft from the front panel and fit the new component supplied, together with its spring and the $1/8$ in. steel ball. Replace the pivot screw and adjust it so that the shaft turns freely without end-play. Replace and tighten the locknut.
- (k) Reverse the sequence of operations given at (g) and turn the FREQUENCY knob clockwise, if necessary, to ensure that it is at the limit of its travel.

WARNING: when subsequently re-engaging the double-start nut mentioned at (e) care must be taken to ensure that the FREQUENCY BAND knob indicates the true position of the switch, as the nut can be made to engage at two diametrically opposite positions.

- (l) Verify that the end lines of the tuning dial are coincident with, or equidistant from, the cursor line at each extreme of the FREQUENCY knob travel: if they are not the tuning dial gear must be disengaged from its worm and moved by the appropriate number of teeth to correct it. When the dial has been correctly adjusted remove the two short lengths of wire inserted at (f) and (h), close up the front panel again and replace the screws removed at (c).

R E S T R I C T E D

ELECTRICAL AND MECHANICAL
ENGINEERING REGULATIONS

TELECOMMUNICATIONS
F 567 Mod Instr No 6

- (m) Strike through the figure 6 on the receiver modification record plate.
- (n) Carry out a complete functional check of the receiver.
- (o) Fit fresh silica gel desiccators, replace the top-cover of the receiver and replace it in its case.
- (p) Carry out the complete drying and sealing procedure given in Tels F 567 Mod Instr No 1 para 7(q)(i) to (ix), substituting the word 'receiver' for 'transmitter' where appropriate; then repeat the functional check.

57/Maint/7216

END