



WS No. 19 Mark III

**This file has been down loaded from
The Wireless-Set-No19 WEB site.**

**All files from this WEB site are free of charge.
If you have been charged for this file then please
contact the person you obtained it from as he/she
has illegally obtained both the file and money they have
charged you.....**

H 4

Crown Copyright Reserved

PW—H4

Post Office Engineering Department

TECHNICAL PAMPHLETS FOR WORKMEN

Subject

Underground Construction Part I—Conduits

ENGINEER-IN-CHIEF'S OFFICE,
1919.

REVISED AND REISSUED SEPT., 1924. PREVIOUS ISSUES
CANCELLED

(*Reprinted March, 1927, including Corrections to date.*)
{ " *January, 1930,* " " " }
{ " *April, 1931,* " " " }
{ " *March, 1933,* " " " }

LONDON

PUBLISHED BY HIS MAJESTY'S STATIONERY OFFICE

To be purchased directly from H. M. STATIONERY OFFICE at the following addresses:
Admiral House, Kingsway, London, W.C.2; 1,0 George Street, Edinburgh;
York Street, Manchester 1; 1 St. Andrew's Crescent, Cardiff;
80 Chichester Street, Belfast;
or through any Bookseller

1936.

Price 6d. Net.

LIST OF Technical Pamphlets for Workmen

GROUP A.

1. Magnetism and Electricity.
2. Primary Batteries.
3. Technical Terms.
4. Test Boards.
5. Protective Fittings.
6. Measuring and Testing Instruments.
7. Sensitivity of Apparatus.
8. Terms and Definitions used in Telegraphy and Telephony.

GROUP B.

1. Elementary Principles of Telegraphy and Systems up to Morse Duplex.
2. Telegraph Concentrators.
3. Wheatstone. Morse Keyboard Perforators.
4. Quadruplex. Telegraph Repeaters, Sx., Dx., and Quad.
5. Hughes Type-printing Telegraph.
6. Baudot Multiplex.
7. Western Electric Multiplex. Murray Multiplex. Other Systems.
8. Fire Alarm Systems.

GROUP C.

1. Wireless Transmission and Reception.
2. Interference with Reception of Broadcasting.

GROUP D.

1. Elementary Principles of Telephony.
2. Telephone Transmission. "Loading." Telephone Repeaters and Thermionic Valves.
3. Principles of Telephone Exchange Signalling.
4. Magneto Exchanges—Non-Multiple Type.
5. Magneto Exchanges—Multiple Type.
6. C.B.S. No. 1 Exchanges—Non-Multiple Type.
7. C.B.S. Exchanges—Multiple Type.
8. C.B. Exchanges—No. 9 Type.
9. C.B. Exchanges—No. 10 Type.
10. C.B. Exchanges—No. 12 Type.
11. C.B. Exchanges—22 Volts.
12. C.B. Exchanges—40 Volts.
13. Trunk Telephone Exchanges.
14. Telephone Exchange Maintenance.
15. Telephone Testing Equipment.
16. Routine Testing for Telephone Exchanges.
17. Internal Cabling and Wiring.
18. Distribution Cases, M.D.F. and I.D.F.
19. Cord Repairs.
20. Superposed Circuits, Transformers, etc.
21. Call Offices.

[Continued on page iii of Cover.]

CORRECTION SLIP TABLE.

The month and year of issue is printed at the end of each amendment in the Correction Slips, and the number of the slip in which any particular amendment is issued can, therefore, be traced from the date. In the case of short corrections made in manuscript, the date of issue of the slip should be noted against the correction.

The Summary portions of the Correction Slips should be completed and affixed below in numerical order.

FOR OFFICIAL USE

UNDERGROUND CONSTRUCTION

PART I,—CONDUITS **(H. 4.)**

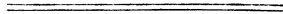

*The following pamphlets in this series are of
kindred interest :—*

- H.5. Underground Construction, Part II.
- H.6. Underground Maintenance.
- H.8. Power Circuit Guarding.

UNDERGROUND CONSTRUCTION.

PART I.—CONDUITS.



TABLE OF CONTENTS.

| | PAGE |
|--|------|
| 1. TYPES OF CONDUITS | 5 |
| 2. EXCAVATION | 7 |
| 3. CONDUIT LAYING | 10 |
| 4. JOINTING POINTS | 14 |
| 5. EARTH PLATES | 31 |
| 6. TESTING BONDED PIPES AND CABLES | 32 |
| 7. TOOLS | 32 |

UNDERGROUND CONSTRUCTION.

PART I.—CONDUITS.

1. TYPES OF CONDUITS.

The **general types of conduits** used by the Post Office are :—

- (a) **Self-aligning ducts (Single and Multiple way), Salt-glazed earthenware.**
- (b) **Creosoted Wood Troughing.**
- (c) **Cast Iron Pipes.**
- (d) **Steel Pipes.**
- (e) **Mild Steel Pipes.**

Details of Conduits are given in Fig. 1.

(a) **Ducts.**—The class of conduit most frequently used is the earthenware duct, fitted with spigot and socket ends and lined with Stanford's composition. The ducts are "self-aligning," *i.e.*, when the spigot of one duct is placed in the socket of another and pressed home, the inside walls coincide and there is no need for further adjustment. The ducts are issued in single and multiple "ways." The single-way types are 3 in. and 4 in. internal diameter respectively, whilst the multiple types are made up in 2, 3, 4, 5, 6 and 9 way sizes, each having an internal diameter of $3\frac{5}{8}$ in.

(b) **Troughing.**—Creosoted Wood Troughing, having a circular internal space of $1\frac{1}{2}$ in. diameter and supplied in lengths from 6 ft. to 20 ft. is used on local underground distribution work when the ultimate development is not likely to exceed 50 pairs of wires. Cases also occur where pole lines in streets are objected to. Troughing is the cheapest form of underground conduit available; it is laid in narrow trenches, also at shallow depths, according to the class of paving disturbed.

(c) **Cast Iron Pipes** have been extensively used in the past, but self-aligning ducts are superseding them. The use of cast iron pipes is now confined to congested thoroughfares, where frequent disturbance of the ground is probable. The pipes are made with spigot and socket ends and are issued in three sizes, 3 in., $3\frac{1}{4}$ in. and 4 in. All sizes are 9 ft. long, exclusive of the socket.

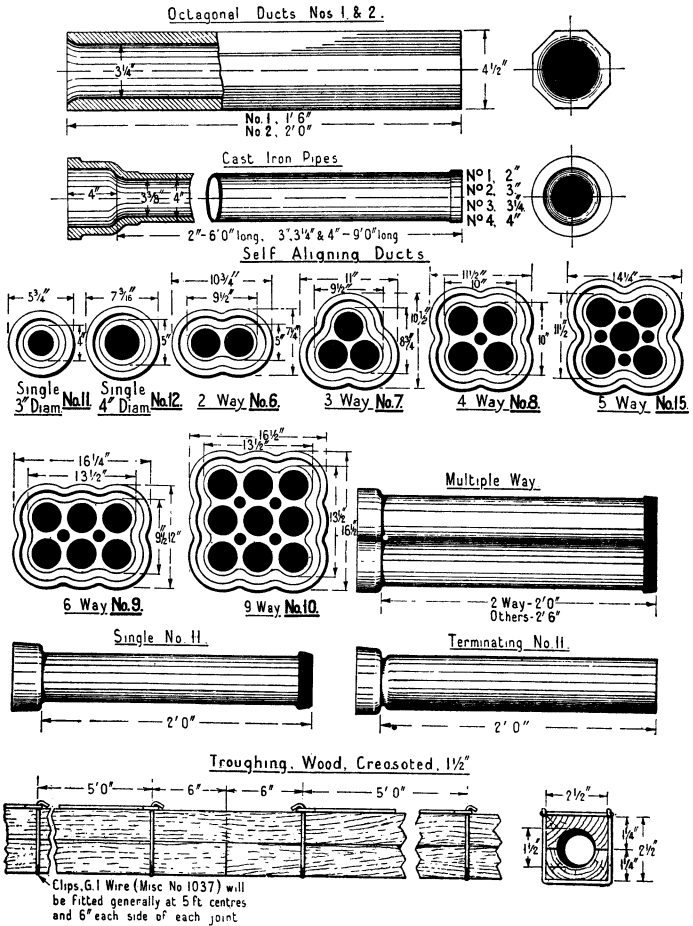

Fig. 1.
EXAMPLES OF CONDUITS.

(d) **Steel Pipes** are used in cases, such, for example, as bridge crossings, where conduits have to be laid shallow and, because of lack of cover, earthenware ducts or cast iron pipes would be liable to fracture. They are also used across bridges or canals, where the pipes have to be slung. Lengths varying from 18 to 28 ft., with spigot and socket ends, are issued. The internal diameter is $3\frac{1}{4}$ in. and the pipes are covered with prepared jute, and coated inside and outside with preservative compound.

(e) **Mild Steel Pipes.**—In cases where a small dimension conduit is required, mild steel pipe is used. It is issued in four sizes, with internal diameters of $\frac{3}{4}$ in., 1 in., $1\frac{1}{2}$ in., and 2 in. Each length is screwed at both ends and one end of each length is fitted with a socket for screw jointing. The smaller sizes are used for taking underground circuits direct into subscribers' premises, under pavements, or enclosures, where the use of Troughing is unsuitable, also for attachment to walls or fences. The $1\frac{1}{2}$ in. and 2 in. sizes are used for the protection of cables which leave the underground system and terminate at Distribution Poles. Mild Steel pipes are also used for leading-in underground cables to important business premises for Block Distribution. Mild steel pipes can be bent locally as required. For the $\frac{3}{4}$ in. size, a pipe vice is used, whilst Jim Crows are employed for bending the larger sizes.

2. EXCAVATION.

Trench Work.—Before the ground is opened, the general route is agreed to and the number and type of conduits decided upon. The route is carefully examined and any Hydrant Indicators, Coal Shutes, etc., located, which may appear, from surface inspection, to be likely to hinder the work. Information is also sought from Local Authorities, in order that any mains, etc., known to exist, may be avoided. The most direct line of trench is taken and, if there is any choice, the route requiring the least expenses in trenching and reinstating is followed. The width of the trench is confined to the narrowest limits.

Every care is taken in planning the route to ensure that the trench will not endanger the footings of old walls or buildings.

When a route is being planned, ground which is known to be waterlogged, running sand, or made up of soft and unstable soil should, if possible, be avoided. In cases where such soil cannot be avoided, or where it is met with in small patches or sections, special precautions will be taken to provide a satisfactory foundation for the duct route. This can be done by laying a 3-in. foundation of concrete, and then bedding the ducts on 3 in. of fine soil on top of the concrete.

Pilot Holes are opened up in advance of, and on the line of, the trench work. A liberal opening of Pilot holes is economical and may be the means of saving expensive diversions later on. Trial holes on the site of jointing chambers are cut both in line

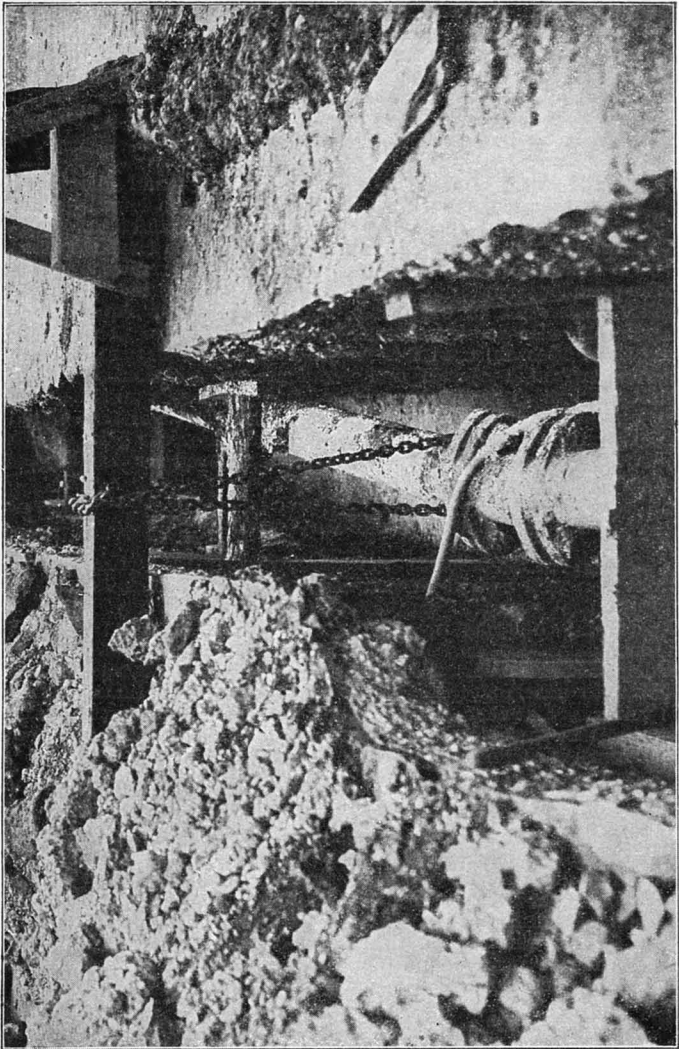

Fig. 2.
METHOD OF SUPPORTING MAINS.

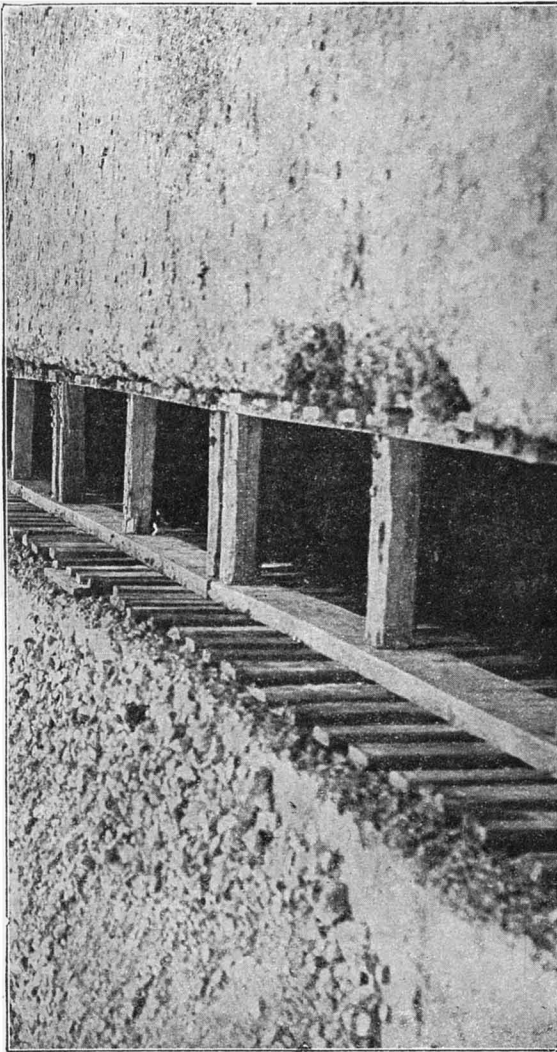

Fig. 3.
"TIMBERING" A TRENCH.

with, and at right angles to, the route. Pilot holes will be cut to a width and depth of at least 6 in. beyond the position proposed for the Department's conduits, in order to disclose the presence of any plant belonging to other undertakers.

Jointing chamber sites are carefully selected in order to avoid obstruction to traffic, both during construction and also when work is carried on in the jointing chambers later.

If plant belonging to other Authorities is met with, every care is taken to avoid interference, and should it be necessary to excavate under plant belonging to other parties, care should be taken to support securely such mains, by means of chains, slung from baulks of wood, placed across the top of the trench. (Fig. 2.)

To guard against any possibility of subsidence of the sub-soil later on, large mains, or nests of ducts, which may have been undercut, through the Department's operations, are supported by brick or concrete pillars built at intervals.

Where self-aligning ducts have to be laid for a distance of 25 yds. or more directly in the carriageways of roads subject to motor lorry traffic, and the soil below the sub-crust is of a yielding nature, the ducts should be surrounded by 3 in. of concrete (one part cement to 12 parts aggregate) in order to prevent movement of the cable due to vibration.

In trenches of abnormal depth, especially in loose soils, it may be necessary to timber the trench (Fig. 3). This timbering is recovered later on, as the filling-in proceeds. In cases where excessive depth near buildings is required, and also in the case of tunnelling, it is sometimes essential to leave the timbering in position permanently.

3. CONDUIT LAYING.

(a) **Self-aligning Ducts** are laid at a depth below the surface, to the top of the body or barrel of the uppermost duct, as follows :—

Single-way :—Roadway, 24 in. ; Footway, 14 in.

Multiple-way :—Roadway, 24 in. ; Footway, 18 in.

The bottom of the trench is well punned and a firm foundation obtained for the ducts. The soil is excavated under the sockets in order that the ducts lie evenly on the bed of the trench. Multiple-way ducts marked with a smudge of black paint will be laid with the marked side underneath. In rocky soils, a layer of loose earth, well rammed, is spread over the bottom of the trench to provide a bedding. If a diversion from the straight line is necessary, a slight "set" not exceeding 1 in. in 24 in. laterally, or 1 in. in 60 in. vertically, is given to the joints but every care is taken when providing the "set" that the test mandrel passes easily through the ducts. If the curve is too sharp to be obtained by a "set," standard bends are used.

As a general rule, concrete is not required for duct work, but where ducts are laid near to gas, water, or other mains, a 3-in. layer of concrete is provided.

Where one line of ducts is laid over another, in the same trench, 3 in. of sifted earth is placed over the lower line of ducts and carefully rammed, so as to provide a firm foundation for the top layer. Sifted earth is also rammed between ducts laid side by side in the same trench. The sockets of ducts in adjacent layers should be "staggered." This is done by using a duct of less than the standard length at the beginning of a Section. Both the spigot and socket ends of the ducts to be jointed are wiped clean, and a coating of Compound No. 6, applied with a brush, is put on at a temperature of about 200 deg. F. The compound must be free from lumps. Every care should be taken to apply the compound evenly, especially on the under sides of the ducts. No dirt or grit must be allowed to cling to the "compounded" spigot or socket when lowering the duct into position.

In the case of multiple-way ducts, a block of wood is held to the face of the duct, and the duct forced home by prizing the wooden block with a crowbar or spade. Single-way ducts are fixed by the use of a spade as a lever. When the ducts are in position in the trench, the joint is well smeared with the compound. Care is taken when filling in the trench to pun the soil lightly and evenly on each side of the ducts and to keep out stones which might cause fractures during punning operations.

To prove the alignment of single-way ducts, a working mandrel of 5 ft. in length is drawn through as the ducts are laid, but where a "set" is given to the ducts, a 9½-in. test mandrel is substituted for the 5-ft. size. In the case of multiple-way ducts, a 9½ in. test mandrel is drawn through each "way" whilst the ducts are being laid, and, after carrying out the mandrel test, a piece of test cable, 6 ft. long, of 3 in. diameter, is drawn through each "way." Finally, on completion of each section of duct work, a brush or mop is drawn through each "way" in order to clear away any dirt which may have entered. In cases where jointing chambers are provided after the ducts are laid, or when any disturbance to the duct line takes place that may affect the alignment, the mandrel test of each "way" will be repeated.

Double spigot ducts are supplied to finish off a section at jointing points.

(b) **Creosoted Wood Troughing.**—The depth or laying below the surface, to the top of cover, for different classes of paving, is shown below.

| | Inches. |
|---|---------|
| Carriageway | 24 |
| Carriageway Paving across Footway | 12 |
| Footway Gravel | 8 |
| Tar, Tarred Gravel, York, Artificial Stone, Asphalte, Granolithic or similar paving .. | 6 |

The width of the trench is kept as narrow as possible and a special spade is used for excavation work.

The bottom part of the troughing is jointed by means of a piece cut from a section of the troughing, 1 ft. in length. This piece is nailed across the underside of the joint by means of eight 2½-in. oval brads. The top half of the troughing is placed in position with the ends well butted together, and the joints "staggered" in such a way that the top half joint does not occur at the same point as the lower half. The two halves of the troughing are bound together with Clips G.I. at intervals of 5 ft. in the runs between the joints and 6 in. each side of each joint.

The interior of the troughing when laid must be free from dirt.

On completion of laying, the earth will be filled in, being lightly punned round the troughing and the upper layers well consolidated.

Cabing in Troughing.—The cable is usually laid in troughing before the cover is placed in position and long lengths of cable are run without joints.

Cable under Tramway Crossings.—Wood troughing must not be used to carry cables under electric tramway tracks. In such cases, iron pipes or earthenware conduits should always be used. To prevent water accumulating in the conduit directly below the tramway tracks, the ducts should be laid so that there is a gradual fall to each side.

Where iron pipes are used they should be carefully bonded to the sheathing of the cable on both sides of the crossing.

(c) **Cast Iron Pipes** are normally laid at a depth of 2 ft. in Carriageways and 14 in. in Footways. In the laying of one pipe, a width of trench of 9 in. in the footway and 12 in. in the carriageway is generally found sufficient. When two or more pipes are laid in one trench, the joints are "staggered." If pipes are laid over each other, 3 in. of well punned earth is placed between them. Pipes are laid with sockets to the front in order that the caulking may help to increase the tightness of pipes already laid. Double socket pipes are supplied for special cases where, for example, spare spigot lengths, which have been cut, can be brought into service. Double spigot pipes are provided at jointing points, to fit Coupling Pieces or Solid Slides. The spigot end is also arranged to enter on each side of Jointing Chambers for Bonding purposes.

Terminating Pipes, either spigot or socket type, are supplied for use at one side, at points where large size cables have to be

jointed. These pipes have a larger diameter than the ordinary pipe and are used either at the beginning or end of a section, to allow the lead sleeve to be passed over the cable and pushed into the Terminating Pipe whilst cable jointing is in progress.

The jointing of cast iron pipes is done by inserting the spigot of one pipe into the socket of its fellow and packing and caulking the space between them with tarred hemp pipe-yarn. A layer of plastic clay is then placed firmly round the mouth of the socket and a small lip formed on the top side of the clay. Molten lead is poured through the lip, until the space between the socket and spigot is filled. After the lead has cooled, the joint is carefully caulked in order to make it solid and water-tight.

These operations are carried out above ground and three pipes are jointed together before they are laid in the ground. The three pipes to be jointed are placed in slotted blocks of wood about 6 in. high and, when they are jointed, the three pipes are carefully lowered into the trench. The free spigot end of the combination lowered into the trench is placed in the socket of the completed section and this joint made in the trench. On completion of a section of pipework, a brush, or mop, is drawn through each conduit followed by an iron test mandrel $9\frac{1}{2}$ in. long.

Bonding.—The bonding of cast iron pipes is necessary to provide a continuous path for any stray currents in the earth, which might be picked up by the conduit. Such currents may enter and leave the lead-covered cable at gaps in the route, set up very serious defects in the lead sheath, and probably result in a breakdown.

The spigot ends of pipes must extend for $1\frac{1}{2}$ in. on the inner walls of jointing chambers and the pipes are drilled to receive a special bonding bolt. This bolt securely clamps a length of 1 in. 8 lb. lead strip to the pipe and the strip is fastened neatly to the sides of the chamber.

In those cases where empty pipes are cut into, at a later stage, for the construction of a jointing chamber, bonding bolts are fitted, but if there are cables in the pipe, too large in size, or too numerous to allow of the drilling of the pipe, a Bonding Clip is fixed. The pipe ends are cleaned and wrapped with a strip of lead, clamped in position by the clip. The inner surface of the clip is slotted in order to take the usual type of 1 in. 8 lb. lead strip. The bolts of the clip are tightened up and the lead wrapping, together with the 1 in. strip, forced into metallic contact with the pipe. The strip connecting the two pipes is then neatly fastened to the sides of the jointing chamber.

Depth of Conduits in grass margin.—If the normal footway depth of 14 in. for cast iron pipes and single-way ducts, and

of 18 in. for multiple-way ducts, provides insufficient cover because of transverse crossings, or if there is a likelihood of the grass margin being converted into carriageway, the question of placing the conduits at an increased depth should be considered.

A wood plug is inserted in the ends of each "way" in every line of conduits, until the length has been tested and passed.

A wire, G.I. 60 lb., is threaded through and left in each "way," intended to be used for immediate cabling.

Steel Pipes are fitted with sockets and spigots and are joined together in the same way as cast iron pipes. Steel pipes may also be joined direct to multiple-way ducts by means of "Connecting Ducts," which are supplied either with spigot or socket ends. One end of each of these ducts is provided with a special lining into which the steel pipe is fixed. By this means, the provision of a jointing chamber at the junction between earthenware duct and steel pipe is avoided.

Bends are not provided for use with steel pipes, as it is found that sufficient "set" is obtained round curves by "springing" the pipes locally.

4. JOINTING POINTS.

Split Couplings (Fig. 4) or Buried Chambers, are used at cable jointing points for single-way ducts or pipes, and also for 2-way and 3-way ducts laid under margin, or under inexpensive pavings. In other cases, where the cost of opening up and reinstating is likely to be high, jointing chambers, of the surface entrance type, are constructed. Special couplings are used for single or double branching points.

At all points where couplings are fixed it is important that the ground be properly filled in and consolidated both below, around, and above the coupling, in order to prevent damage to the ducts or cable by subsidence.

The two halves of couplings are bolted together, care being taken to apply pressure gradually so that stoneware ducts are not fractured. The ends and flanges of couplings used for ducts are served with Compound No. 6, and yarn, coated with the mixture, placed between the flanges of the coupling to make the combination as water-tight as possible.

In the case of couplings for Cast Iron Pipes, the flanges are slotted to receive pins and cotters. The joint between the flanges is made with yarn and Mixture No. 2, whilst, to preserve electrical continuity, the ends of the coupling are caulked and leaded.

No. 2. Coupling, Split, Distribution, for 3" & 3 1/4" C.I. Pipes, & 3" Self-aligning Ducts No. 11.

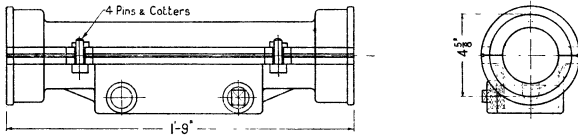

No. 5. Coupling, Split, for 3" & 3 1/4" C.I. Pipes, & 3" Self-aligning Ducts No. 11.

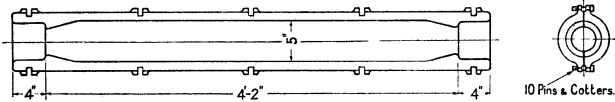

No. 8. Coupling, Split, for 4" C.I. Pipes, & 4" Self-aligning Ducts No. 12.

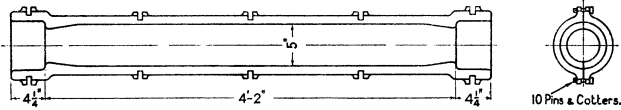

No. 10. Coupling, Split, with groove, for 3" & 3 1/4" C.I. Pipes, & 3" Self-aligning Ducts No. 11.

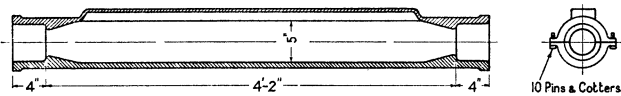

No. 13. Coupling, Split, with branches, for 3" & 3 1/4" C.I. Pipes, & Self-aligning Ducts No. 11.

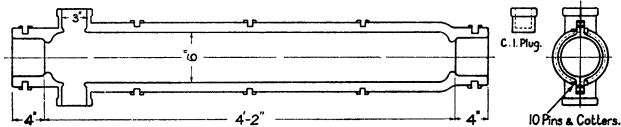

No. 17. Coupling, Split, with branch for Ducts No. 11 & **No. 19.** Coupling, Split, with branch for Ducts No. 12

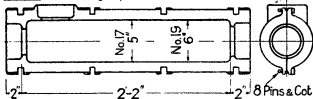

No. 18. Coupling, Split, for Ducts Nos. 11 & 12.

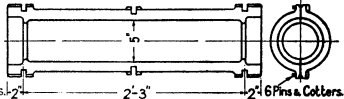

Fig. 4.

EXAMPLES OF COUPLINGS.

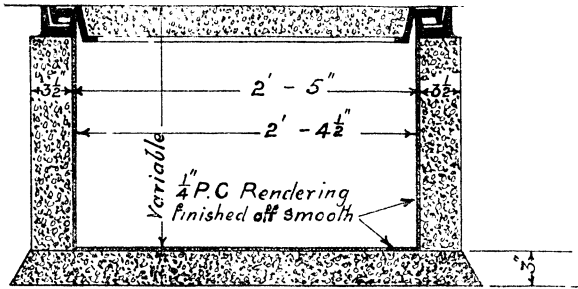

Fig. 5.—CHANNEL JOINT BOX, CONCRETE. (J.R.F. 2.)
Showing general construction of all types of Concrete Channel Joint Boxes.

Joint Box Channels are built up either by means of concrete (Fig. 5) or brickwork (Fig. 6) and are fitted with Cast Iron Channel frames to suit the cover. All covers of joint box channels and man-holes are fitted with Artificial Stones. The channels are constructed in seven different sizes to meet requirements.

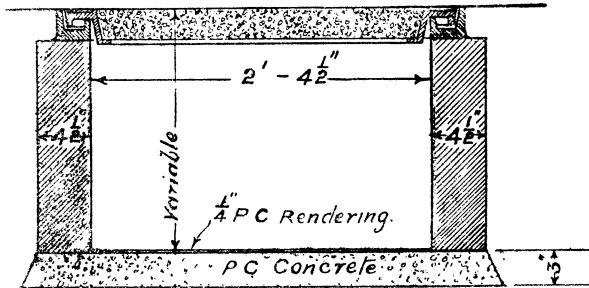

Fig. 6.—CHANNEL JOINT BOX, BRICKWORK. (J.F. 2.)
Showing general construction of all types of Brickwork Channel Joint Boxes.

A Distribution Box is used on single-way routes carrying subscribers' small cables for through, or branch joints.

The Small and Large Boxes are used on single-way routes for through, or branch joints, on larger cables, in town areas.

The Extra Large Box will accommodate two conduits, and is used for main cable jointing, and also for important distribution cable joints.

Junction Boxes.—Where conduits have to be laid at a greater depth than 18 in., a larger box is provided, in order that the jointer may have room to work. Junction Boxes are also used for important branch cable joints, or where the route turns at right angles. They provide room for three conduits. The Double Junction Box is used for three main cable joints. This

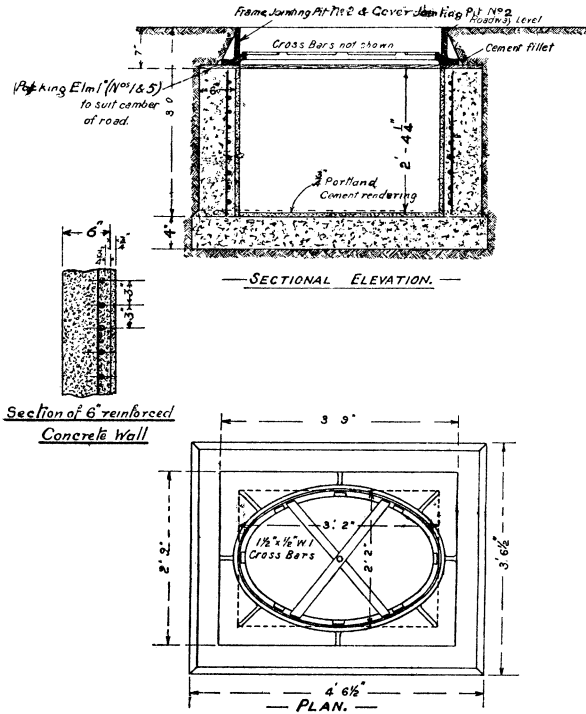

Fig. 7.

CARRIAGEWAY JOINTING CHAMBER, SURFACE ENTRANCE, REINFORCED CONCRETE. (J.R.C. 1.)

box is fitted with two covers, each of similar size to the Single Junction cover. A movable crosspiece is placed across the centre of the frame into which the lips of the two covers fit. The line of conduits should run near to one side of the chamber and not across the centre. The cables are thus in a safer position and brackets and bearers can be more readily fitted. The double junction box with extension provides additional length for the long joints necessary on balanced cables.

A Carriageway Jointing Pit (Figs. 7 and 8) is used in expensive roadway pavements, where the conditions do not justify the provision of a manhole. An oval cover is fitted in this case and the pit will accommodate two conduits.

Wherever it is economical to do away with a surface entrance, namely, in cases where straight through joints on main cables are made in margins or under inexpensive pavings, **buried boxes of Reinforced Concrete or Brickwork** are constructed. (Figs. 9, 10 and 11.)

The position of Couplings and Buried Boxes is indicated by **Marking Posts or Joint Markers**. The Posts are generally used on country roads and placed in the hedgebanks. Each Marking Post is fitted with a slot into which figures are inserted to show the distance of the cable joint from the Post. Joint Markers are placed flush with the surface of the road, immediately over the joint, and are attached to the coupling, etc., by means of a chain.

Manholes of Carriageway or Footway types are constructed either of—

- (a) Reinforced concrete throughout.
- (b) Brickwork with reinforced concrete roof.
- (c) Brickwork throughout fitted with steel joists and boiler plate.

Examples of representative types of manholes are given in Figs. 12 to 17 inclusive.

In footway types, the manhole frames and covers are square, and the ordinary Junction Box cover is fitted; whilst in the case of roadway manholes, circular openings are provided, the covers being fitted with hardwood blocks, cemented in.

Light and Heavy Roadway Manhole Frames are provided to meet traffic conditions. The frame rests on **elm packing** pieces, by this means the frame and can be adjusted to coincide with the slope of the road.

Sump Holes are sunk in a convenient position in all manholes, and are fitted with a 2-ft. length of 9 in. glazed earthenware drain pipe. The socket is placed upward and brought to the level of the cement floor. The bottom of the drain pipe is floated with concrete and a cast iron grating fitted in the socket. The floor of the manhole is given a slight fall towards the Sump Hole.

Anchor Irons are fitted in the four corners of every manhole in order to anchor the tackle during cabling operations.

Steps are fixed in the walls of manholes during construction.

In cases where, owing to the presence of other mains, etc.

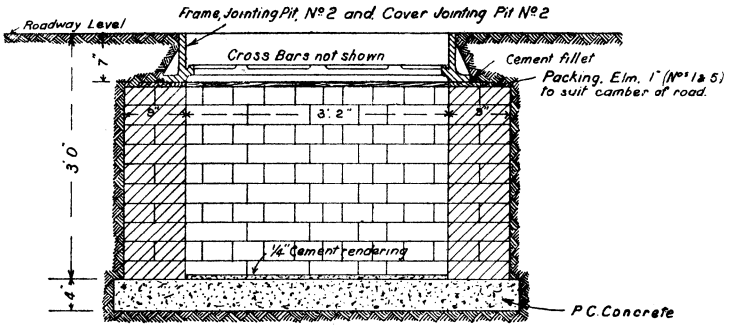

SECTIONAL ELEVATION.

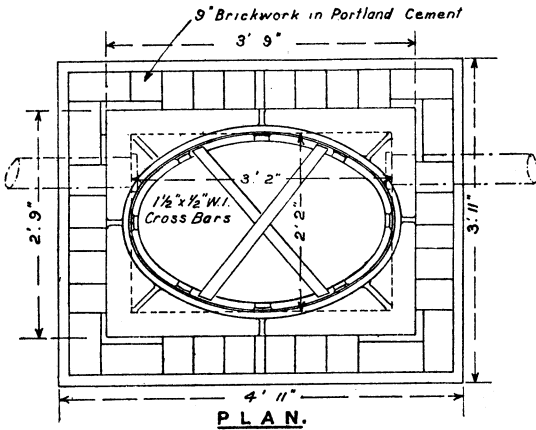

PLAN.

Fig. 8.

CARRIAGEWAY JOINTING CHAMBER, SURFACE ENTRANCE, BRICKWORK. (J.C. 1.)

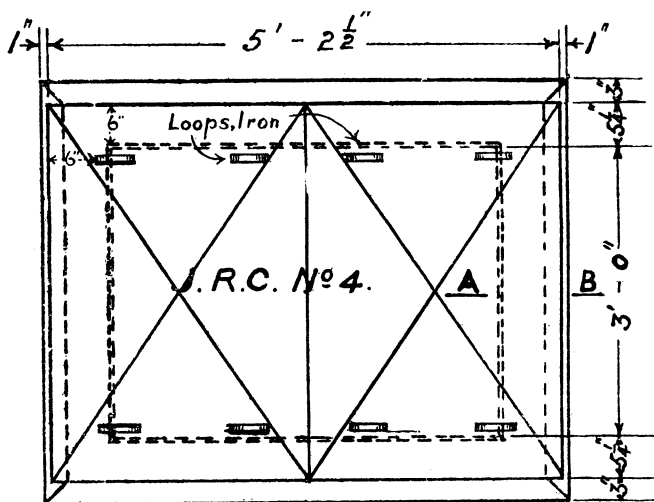
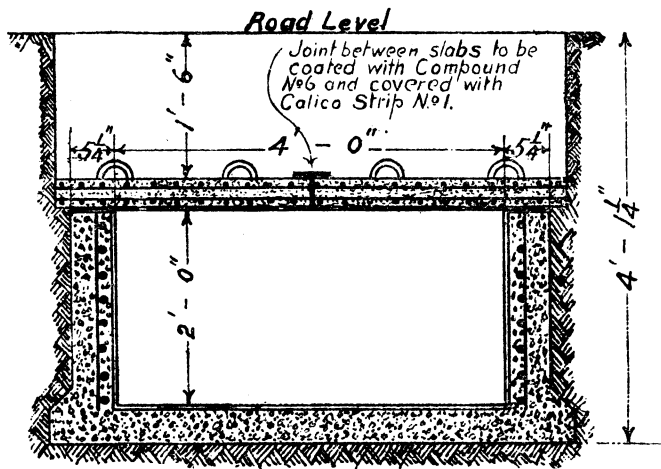
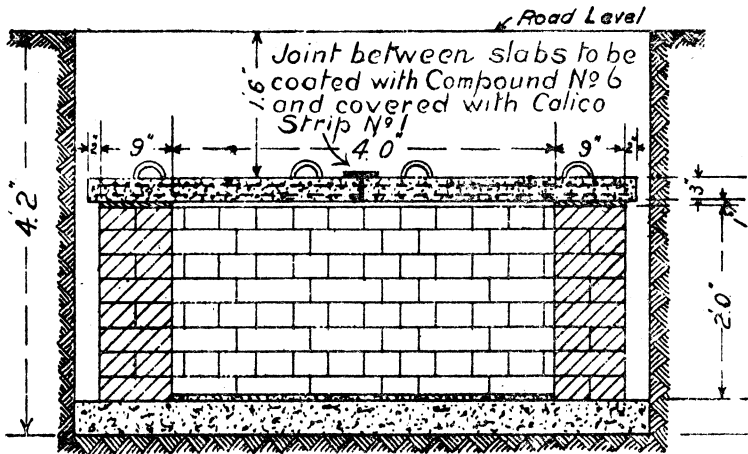

Fig. 9.

**CARRIAGEWAY JOINTING CHAMBER (BURIED)
REINFORCED CONCRETE. (J.R.C. 4.)**

Showing general construction of all types of Buried Reinforced Concrete Carriageway Jointing Chambers.



SECTION

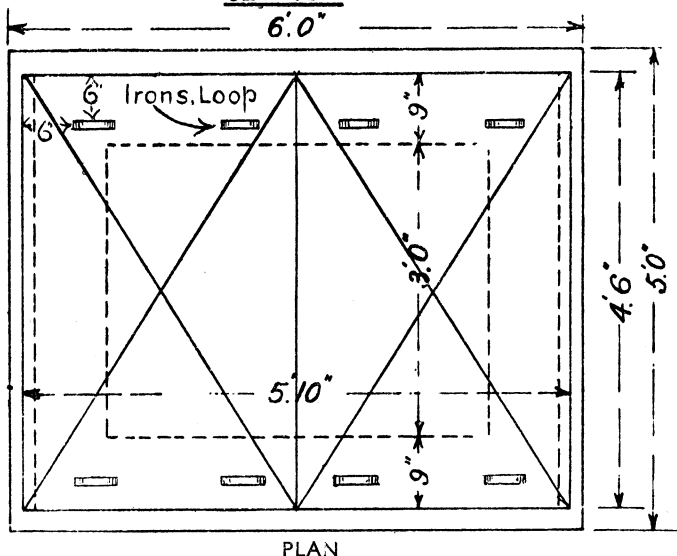

PLAN

Fig. 10.

CARRIAGEWAY JOINTING CHAMBER (BURIED) BRICKWORK, WITH REINFORCED CONCRETE ROOF. (J.C.C. 4.)

Showing general construction of all types of Buried Brickwork Carriageway Jointing Chamber, fitted with Reinforced Concrete Roofs.

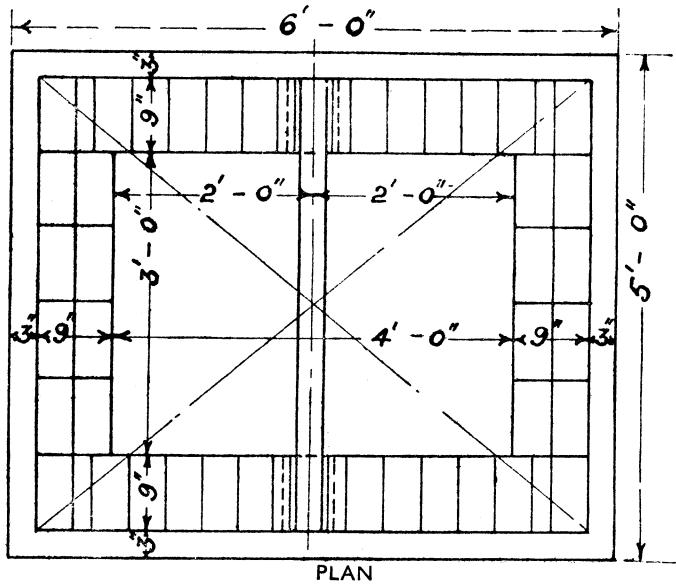
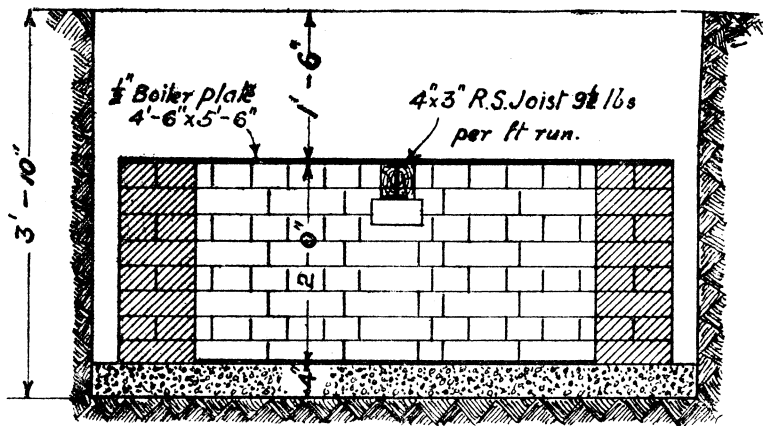

Fig. 11.

CARRIAGEWAY JOINTING CHAMBER (BURIED),
BRICKWORK. (J.C. 4.)

Showing general construction of all types of Buried Brickwork Carriageway Jointing Chambers.

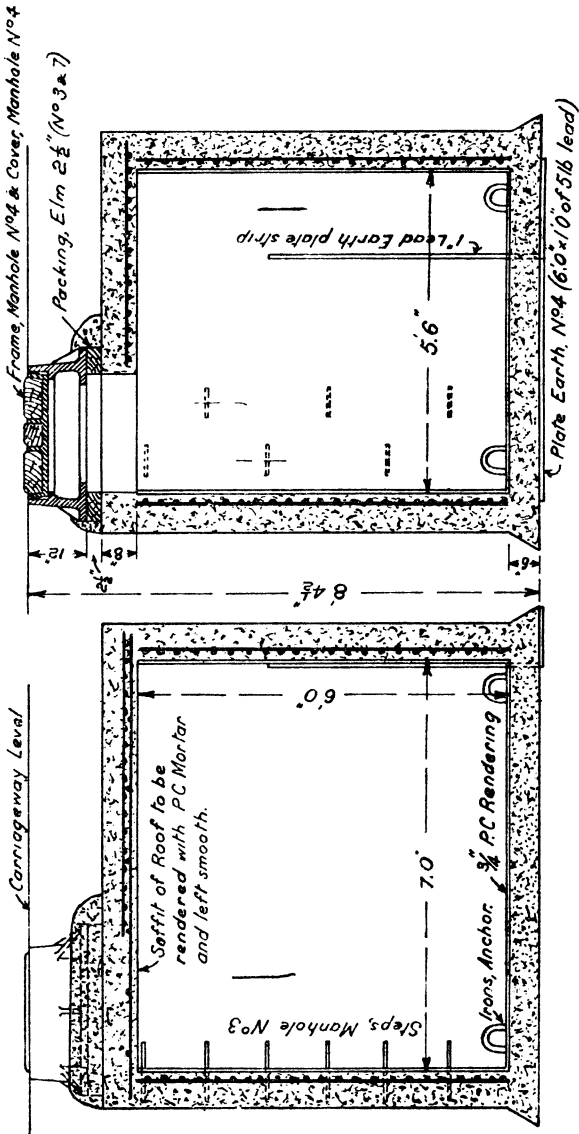

Fig. 12.

CARRIAGEWAY MANHOLE, REINFORCED CONCRETE. (R.C.C. 7.)

Showing general construction of all types of Reinforced Concrete Carriageway Manholes.

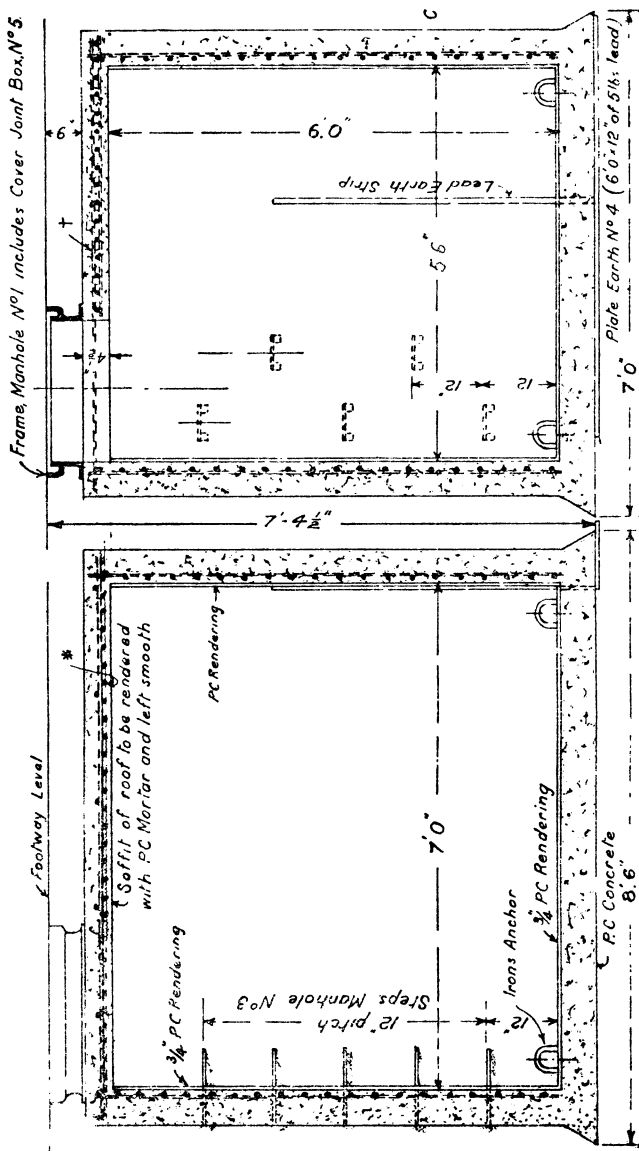

Fig. 13.

FOOTWAY MANHOLE, REINFORCED CONCRETE. (R.C.F. 7.)
 Showing general construction of all types of Reinforced Concrete Footway Manholes.

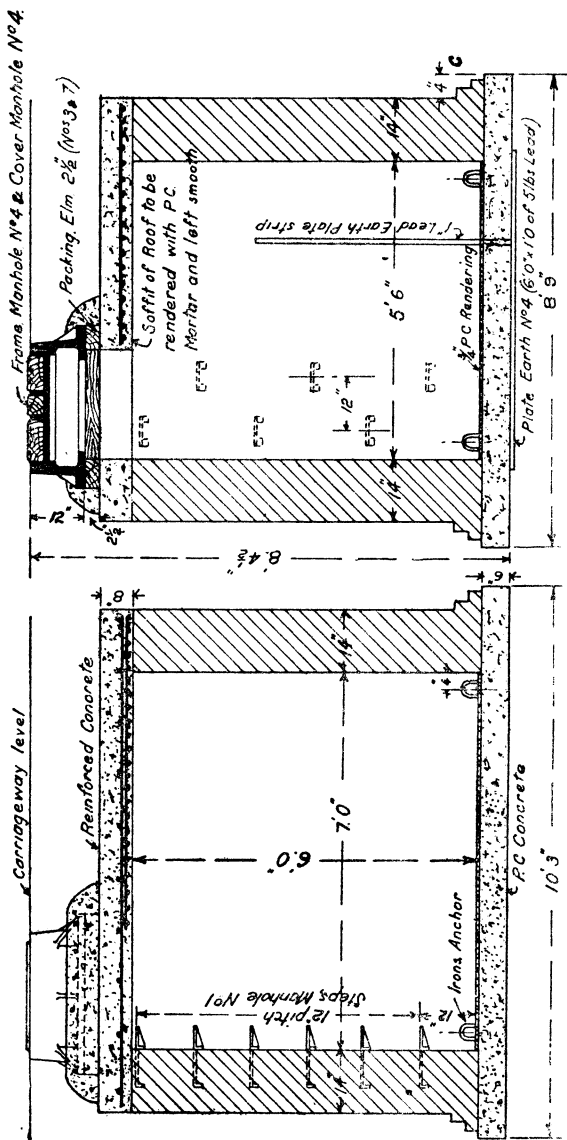

Fig. 14.

CARRIAGEWAY MANHOLE, BRICKWORK, WITH REINFORCED CONCRETE ROOF. (C.F. 7.)
 Showing general construction of all types of Brickwork Carriageway Manholes, fitted with Reinforced Concrete Roofs.

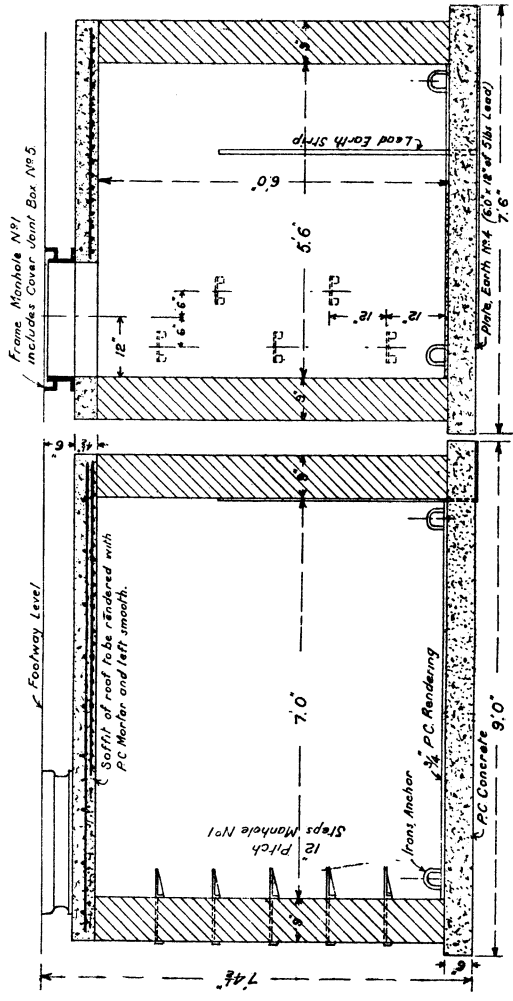
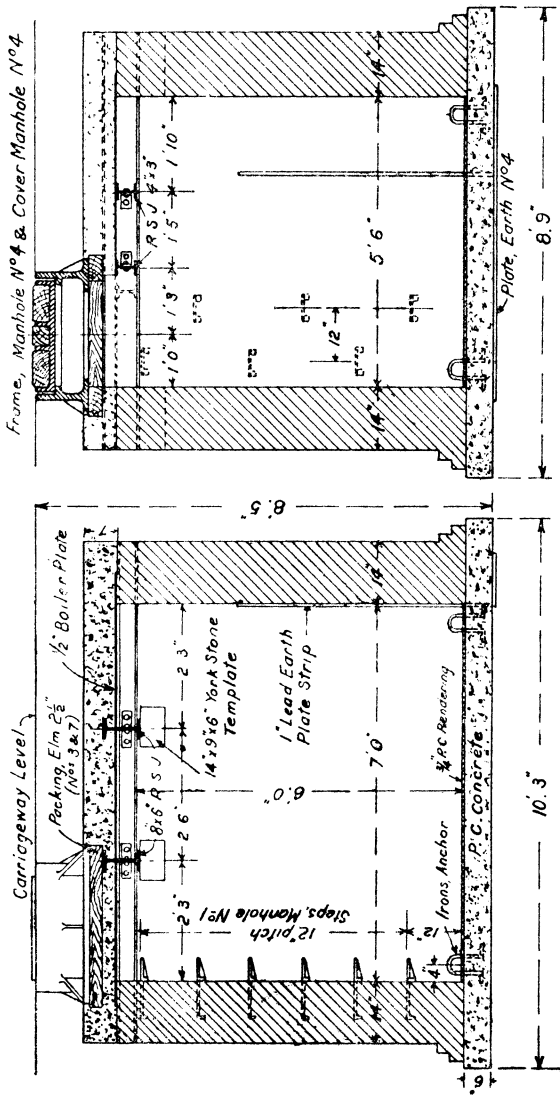

Fig. 15.
FOOTWAY MANHOLE, BRICKWORK, FITTED WITH ROLLED STEEL JOISTS AND YORK STONE ROOF. F.7.
Showing general Construction of all types of Brickwork Footway Manholes.



SECTION C.D.

SECTION A.B.

Fig. 16.

CARRIAGEWAY MANHOLE, BRICKWORK, FITTED WITH ROLLED STEEL JOISTS AND BOILER PLATE ROOF. (C. 7.) Showing general construction of all types of Brickwork Carriageway Manholes.

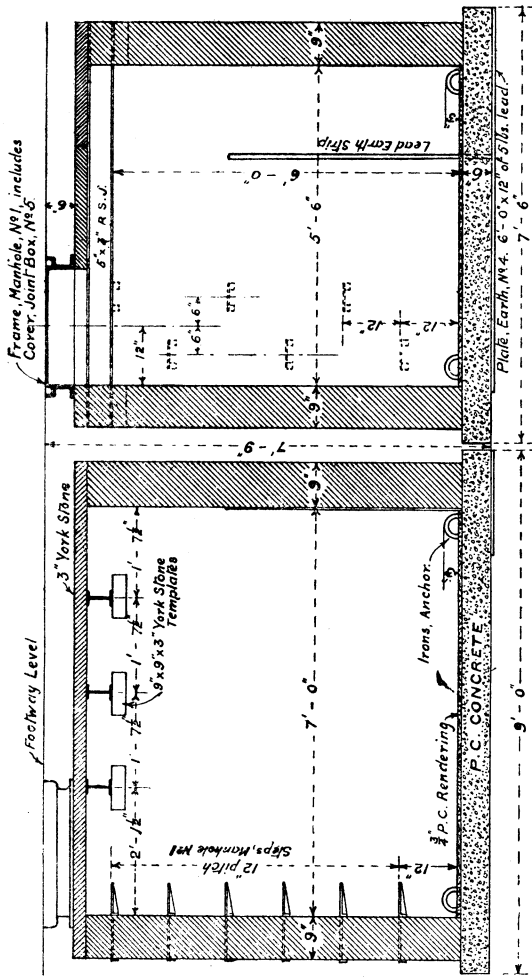

Fig. 17.

FOOTWAY MANHOLE, BRICKWORK, WITH REINFORCED CONCRETE ROOF. (F.F.F.)
 Showing general construction of all types of Brickwork Footway Manholes, fitted with Reinforced Concrete Roofs.

it is not possible to construct the roof of a manhole near the surface, a **concrete or brick shaft** is built.

In wet situations, the outside of the jointing chamber may be surrounded with 6 in. of well pugged clay, or the inside walls rendered with **1 in. waterproofed cement mortar**.

In exceptionally wet situations it may be necessary to cover the bottom and a portion of the sides of the excavation with a tarpaulin, in order to prevent the water from damaging the concrete by washing away the cement.

Method of Increasing Length of Jointing Chamber.—Where it is necessary to provide additional jointing space in manholes, concrete extensions may be provided in accordance with diagram E.C. 1288 shown in Fig. 18.

Reinforced Concrete Jointing Chambers.—It is important that reinforced concrete work be carried out with strict attention to detail, in order that full advantage of this form of construction may be obtained.

All the materials used should be free from dirt, and the tools employed should be clean. The Portland Cement should be "slow setting," the mixing thoroughly done and the cement properly distributed in the ballast. Neglect in mixing, or the addition of too much water, may entirely spoil the work. The mixing of the concrete and the filling in of the moulds and framings should, when once started, be carried through to completion. The ground is excavated to the required dimensions and the sides slightly undercut to make room for the concrete foundation and the wall footings. The floor is levelled and well punned and the sump hole fitted. In the case of earthenware ducts, a lead Earth Plate, fitted with a lead strip connection, is laid under the floor. The concrete floor is laid and four Anchor Irons—one in each corner—inserted in the concrete. A roughened face is left on the concrete surface, where the walls will be constructed, in order to form a "key."

The flooring, when once completed, should not be walked upon, or disturbed, for at least 12 hours, after which, by covering it with sacks, overlaid with boards, the erection of the framing for the walls is put in hand.

Centerings and framings should remain rigid during the laying and tamping of the concrete and no shaking or jarring should occur during the setting period.

Manhole steps and other wall fittings are inserted through slots cut in the shuttering. The steps should not be used for at least 48 hours after the concrete has been filled in. A small wooden ladder is used as an alternative.

All conduits in jointing chambers are carefully plugged until the work is completed in order to prevent moist concrete from entering the conduits.

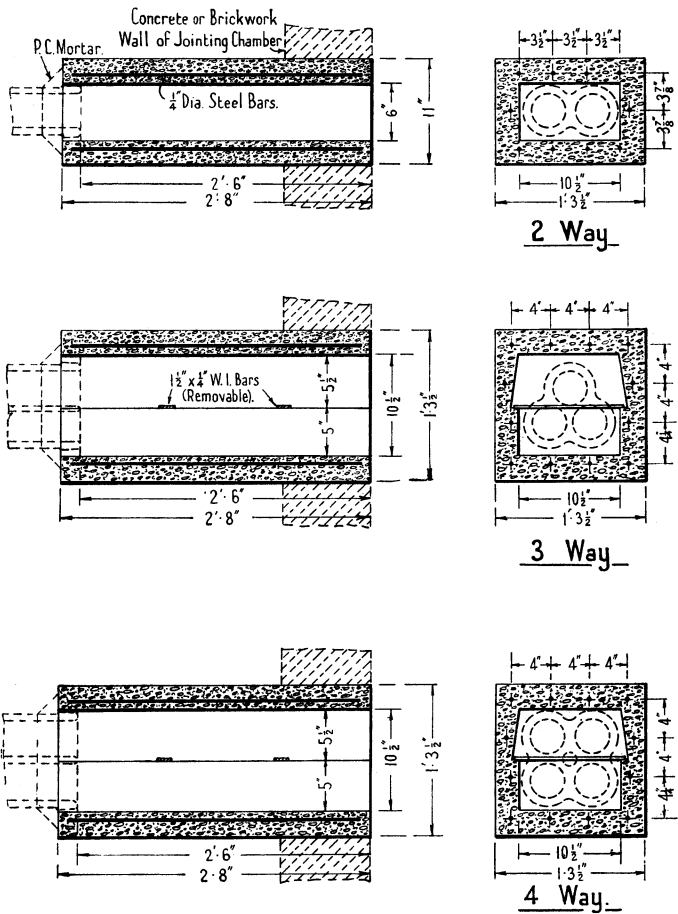

Fig. 18.

When the framing is fixed, the reinforcing material is carefully placed in position and the concrete filled in and lightly tamped. The concrete is kept moist for at least 7 days to ensure proper setting. Protection from frost and too rapid drying is effected by covering the work with sacks.

The centerings and framings should remain in position for at least 7 days, and be so constructed that the various parts, when dismantled, may be withdrawn through the roof entrance.

Jointing Chambers should be examined at regular intervals and their condition reported upon. They should be kept free from the accumulation of refuse. All ironwork should be thoroughly scraped and painted once in every two years.

The frames and covers of all jointing chambers should not be allowed to project above the level of the footway or roadway pavements. Care is taken to ensure that all covers fit properly and also that they do not "rock." Neglect of these important points may result in serious accidents to the public.

The horizontal bars of Cable Bearers are provided with a pad of sheet lead (5 lbs.) in order to protect the sheathing of lead-covered cables from injury.

5. EARTH PLATES.

The efficient earth wiring of Protectors, Main Distribution Frames, Test Boxes, Test Panels, Cable Connection Boxes, Cut Outs, etc., is of the utmost importance. It is imperative that good earth connections be obtained in all cases, and care is taken to see that all earth wires are run as straight as possible.

For Telephone Exchange and Telegraph Office working, a galvanised iron earth plate, 2 ft. 6 in. square, is sunk vertically in a moist position, the top of the plate being at least 2 ft. from the surface. The earth plate required for use in connection with cables in jointing chambers into which stoneware ducts are led is referred to on page 27. The cables are bonded together by a strip of 8 lb. lead, 2 in. wide, soldered to the cables and also to the earth connection.

The earth wire attached to the plate is connected to a Soft Copper wire (19/16 strand). The number of earth plates fitted at any one point depends upon the size of the Exchange and the nature of the soil. Generally speaking, an Exchange of 5,000 lines capacity, requires 4 earth plates. The resistance to earth, including the earth lead, must be under 1 ohm.

In soils where acids are present and corrosion of the iron plate likely to be fairly rapid, a Copper Earth Plate (4 ft. by 4 ft.) is used.

For minor offices and subscribers' circuits, Earth Clips fastened to iron water mains are used instead of earth plates, but where the resistance of mains or pipes reaches 10 ohms, G.I. Earth Plates are used as described above.

Connection to iron water pipes up to $1\frac{1}{2}$ in. diameter are made by means of "Clips, Earth, for Water Pipe," whilst for water pipes, exceeding $1\frac{1}{2}$ in. diameter, a Bonding Clip of suitable size is used. Gas pipes must not be used as earth connections.

6. TESTING BONDED PIPES AND CABLES

A yearly test of all bonded pipes in jointing chambers is made by means of a small portable testing set, consisting of a dry cell and a Detector. The brass clamp of the testing set is screwed to the lead bonding strip, and the wire from the other terminal fastened securely in metallic contact to a knife or other suitable item. Contact between the knife and C.I. pipe is made and the deflection through the "Q" coil noted. Whilst this connection is maintained, a second wire, fastened to the knife, is placed in direct contact with the lead strip near the brass clamp. If the bonding is efficient the first deflection will remain unaltered whilst the second connection is made and broken.

If desired to test the bonding of cables, the cable sheath is cleaned (not scraped) and the knife held in good contact.

Tests of bonding prove that it is possible to keep the resistance of a bond below $\cdot 005\omega$, and this figure is regarded as a maximum. When the Detector records a deflection between 50 and 60 divisions, the insertion of half an ohm in circuit produces a variation of about three scale divisions.

7. TOOLS.

Every care is taken to see that tools are checked on receipt at the commencement of the work and given into the charge of a responsible official. The tools will be kept in a secure place, regularly cleaned and sharpened, and a sufficient reserve held to meet urgent renewals. The person held responsible will see to the handing out and return of tools each day and that all losses or breakages are promptly reported.

The fencing and guarding of all excavation work, especially at night time, are important matters, and an adequate supply of lamps and lamp stores must be on hand.

LIST OF Technical Pamphlets for Workmen

(Continued)

GROUP E.

1. Automatic Telephony. Step by Step Systems.
2. Automatic Telephony. Coder Call Indicator(C.C.I.) Working.
3. Automatic Telephony. Keysending " B " positions.

GROUP F.

1. Subscribers' Apparatus C.B.
2. Subscribers' Apparatus C.B.S., Part I—C.B.S. No. 1 System.
3. Subscribers' Apparatus Magneto.
4. Private Branch Exchange—C.B.
5. Private Branch Exchange—C.B. Multiple, No. 9.
6. Private Branch Exchange—Magneto.
7. House Telephones.
8. Wiring of Subscribers' Premises.

GROUP G.

1. Secondary Cells, Maintenance of.
2. Power Plant for Telegraph and Telephone Purposes.
3. Maintenance of Power Plant for Telegraph and Telephone Purposes.
4. Telegraph Battery Power Distribution Boards.

GROUP H.

1. Open Line Construction, Part I.
2. Open Line Construction, Part II.
3. Open Line Maintenance.
4. Underground Construction, Part I.
5. Underground Construction, Part II.
6. Underground Maintenance.
7. Cable Balancing.
8. Power Circuit Guarding.
9. Electrolytic Action on Cable Sheaths, etc.
10. Constants of Conductors used for Telegraph and Telephone Purposes.

GROUP I.

1. Submarine Cables.

GROUP K.

1. Electric Lighting.
2. Lifts.
3. Heating Systems.
4. Pneumatic Tube Systems.
5. Gas and Petrol Engines.