



WS No. 19 Mark III

**This file has been down loaded from
The Wireless-Set-No19 WEB site.**

**All files from this WEB site are free of charge.
If you have been charged for this file then please
contact the person you obtained it from as he/she
has illegally obtained both the file and money they have
charged you.....**

Post Office Engineering Department

TECHNICAL PAMPHLETS FOR WORKMEN

Subject :
**Telephone Testing
Equipment.**

ENGINEER-IN-CHIEF'S OFFICE,
1919.

(*Reprinted March, 1926, including Correction Slips to date.*)

(*„ April, 1929, „ „ „ „ „*)

LONDON :

PRINTED AND PUBLISHED BY HIS MAJESTY'S STATIONERY OFFICE.

To be purchased directly from H.M. STATIONERY OFFICE at the following addresses :

Adastral House, Kingsway, London, W.C.2 ; 120, George Street, Edinburgh ;
York Street, Manchester ; 1, St. Andrew's Crescent, Cardiff ;
15, Donegal Square West, Belfast ;
or through any Bookseller.

1929..

Price 6d. Net.

== LIST OF ==
Technical Pamphlets for Workmen.

GROUP A.

1. Magnetism and Electricity.
2. Primary Batteries.
3. Technical Terms.
4. Test Boards.
5. Protective Fittings.
6. Measuring and Testing Instruments.
7. Sensitivity of Apparatus.

GROUP B.

1. Elementary Principles of Telegraphy and Systems up to Morse Duplex.
2. Telegraph Concentrators.
3. Wheatstone. Morse Keyboard Perforators.
4. Quadruplex. Telegraph Repeaters, Sx., Dx., and Quad.
5. Hughes Type-printing Telegraph.
6. Baudot Multiplex.
7. Western Electric Multiplex. Murray Multiplex. Other Systems.
8. Fire Alarm Systems.

GROUP C.

1. General Principles of Wireless Transmission and Reception.

GROUP D.

1. Elementary Principles of Telephony.
2. Telephone Transmission. "Loading." Telephone Repeaters and Thermionic Valves.
3. Principles of Telephone Exchange Signalling.
4. Magneto Exchanges—Non-Multiple Type.
5. Magneto Exchanges—Multiple Type.
6. C.B.S. No. 1 Exchanges—Non-Multiple Type.
7. C.B.S. Exchanges—Multiple Type.
8. C.B. Exchanges—No. 9 Type.
9. C.B. Exchanges—No. 10 Type.
10. C.B. Exchanges—No. 12 Type.
11. C.B. Exchanges—22 Volts.
12. C.B. Exchanges—40 Volts.
13. Trunk Telephone Exchanges.
14. Telephone Exchange Maintenance.
15. Telephone Testing Equipment.
16. Routine Testing for Telephone Exchanges.
17. Internal Cabling and Wiring.
18. Distribution Cases, M.D.F. and I.D.F.
19. Cord Repairs.
20. Superposed Circuits, Transformers, etc.
21. Call Offices.

[Continued on page iii of Cover.]

TELEPHONE TESTING EQUIPMENT

*The following publications are of kindred
interest :*

Technical Pamphlet, P.W.—D. 16. ROUTINE TESTING
FOR TELEPHONE EXCHANGES.

P O. Technical Instruction II. EXCHANGE TESTING
EQUIPMENT.

TELEPHONE TESTING EQUIPMENT

TABLE OF CONTENTS.

	PAGE
GENERAL DESCRIPTION OF EXCHANGE TEST AND PLUGGING-UP POSITIONS AND CIRCUITS ...	3
SCHEDULE OF TESTING OPERATIONS	5
GENERAL DESCRIPTION OF ENGINEER'S TEST DESK AND CIRCUITS	12
SCHEDULE OF TEST DESK CIRCUITS	14
DETAILED DESCRIPTION OF TEST CORD CIRCUIT...	26
FUNCTIONS OF KEYS IN TEST CORD CIRCUIT ...	28
SCHEDULE OF KEYS TO BE OPERATED FOR VARIOUS TESTS	30

TELEPHONE TESTING EQUIPMENT.

At all exchanges it is essential that failures and interruptions on the services should receive prompt attention and that the circuits should be restored to normal working as quickly as possible.

At C.B. exchanges, a special testing position known as the "Exchange Test and Plugging-up position" is fitted with the suite of switch sections from which all preliminary tests to ascertain the cause of faults on circuits are made by a telephonist specially detailed for this duty. By this means the traffic staff are able to make sure that a fault actually exists, and are able to distinguish so some extent between traffic trouble and faults which require the attention of the engineering staff.

In addition to the above, a second testing equipment is provided in the apparatus or test room at which all fault reports passed forward from the exchange test position for attention are dealt with, and all new lines thoroughly tested out before being connected to the Exchange.

GENERAL DESCRIPTION OF EXCHANGE TEST AND PLUGGING-UP POSITIONS AND CIRCUITS.

The exchange test and plugging-up equipment is generally fitted on the last "A" section of the switchboard in order that tests may be made with the whole of the subscribers' multiple in circuit.

An illustration of an exchange test and plugging-up position is shown in Fig. I.

Testing
Position.

Voltmeter above
subscribers'
Multiple, Testing
Keys and Docket
Distributor
below junction
multiple.

“Plugging-up” Position.

Keys, Lamps and Jacks for
60 cord circuits below
multiple. Some of the cords
are fitted on the testing
position.

Docket
Tube to
and
from
Test
Desk

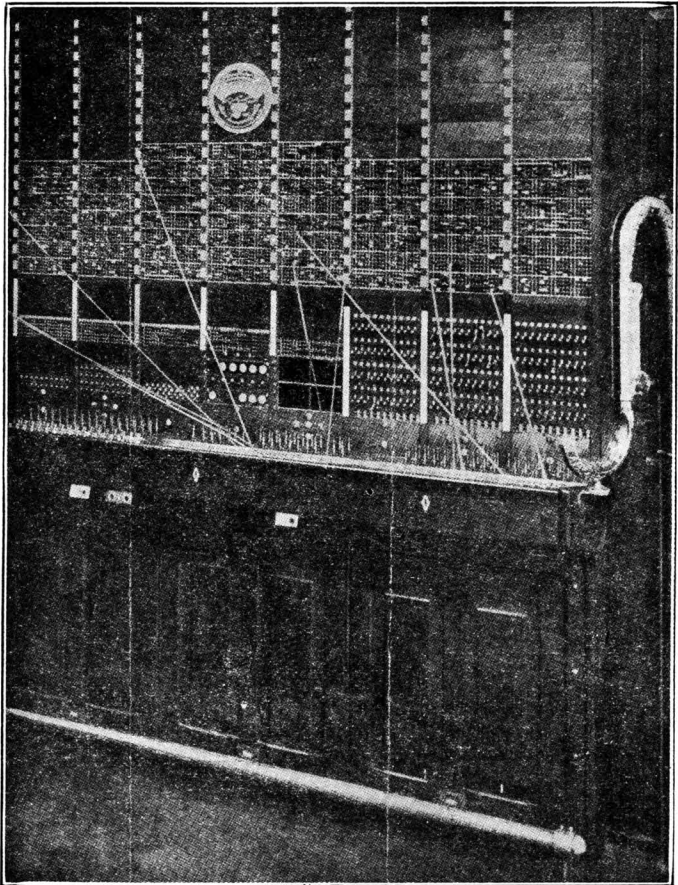

Fig. 1.—TESTING AND “PLUGGING-UP” POSITIONS.

SCHEDULE OF TESTING OPERATIONS.

EXCHANGE TEST POSITION.—*Cont.*

Test for :—	Key or Keys to be Operated.	Normal Result of Test.	Failure to obtain Normal Result indicates :—
(c) Short circuit or receiver off (<i>see</i> Note 2)	No. 6 and 8 (voltmeter and earthing)	No deflection or deflection steady and less than standard specified by engineer.	Short circuit or receiver off.
(d) Disconnection on Sub.'s line or instrument	No. 6 and 8, and, in addition, operate key 7 two or three times quickly	"Throw" of voltmeter needle about half way across scale each time key 7 is operated	Circuit disconnected.
(e) Current on B line	No. 6 and 9 (voltmeter and receiving negative)	No deflection ..	Stray current on B line. Possibly in contact with another circuit.
(f) Do. A line..	No. 6, 7 and 9	Do.	Do. A line.
(g) Sub.'s calling equipment (using "loop" on test cord)	No. 10 (call exch.)	"A" telephonist answers call. Number of answering jack should agree with number of multiple jack on test position	Defective answering equipment, wrong number plate or contact in exchange.
(h) Do. (using "loop" via sub.'s telephone set)	No. 4 and 10 ("sub.'s batt. and call exch. cut off" and "call exch.")	Do. if sub.'s line is looped	Do.

The remaining keys provide the following facilities :—

(i) Ringing ordinary sub. or "X" P.L. sub.	No. 1 ..	Sub. answers ..	Bell faulty. No reply or line disconnected.
--	----------	-----------------	---

SCHEDULE OF TESTING OPERATIONS.

EXCHANGE TEST POSITION.—*Cont.*

The remaining keys provide the following facilities.—Cont.

Test for :—	Key or Keys to be Operated.	Normal Result of Test.	Failure to obtain Normal Result indicates :—
(k) Ringing " Y " P.L. sub.	No. 2 ..	Sub. answers ..	Bell faulty. No reply or line disconnected.
(l) Howler.. ..	No. 3 ..	For use when tests indicate that sub.'s receiver is off the hook	<i>Note.</i> —Before applying the Howler, care should be taken in every case first to ascertain that no one is listening on the line.
(m) Test plug cut off	No. 5 ..	For use when testing telephonist desires to speak on another cord circuit on position without withdrawing test plug	—
(n) Speaking to C.B. sub. or another telephonist <i>via</i> ordinary lines on position	All keys in normal position	—	—

Note 1.—When making tests (a) and (b) a deflection of the voltmeter needle may be due to the line being in contact with another circuit to which a battery is connected. In order to verify that the observed deflection is not due to a "stray current" on the line, key No. 9 (receiving negative) is thrown, in cases of doubt, in addition to the keys specified in the two tests.

Under the latter condition, a deflection indicates that there is a fault "current on the line" which may be due to a contact or to a faulty spring on the cut off relay, etc.

Note 2.—Short circuit or "Receiver Off" faults. When applying test (c), if there is any doubt as to whether a certain deflection is caused by "receiver off" or "short circuit" on line, test (g) or (h) should be applied. If the "A" telephonist can then be heard distinctly, it may be assumed that the fault is due to "receiver off." A short circuit will cause the "A" telephonist to be heard very faintly.

Note 3.—Contact or over-hearing faults. If, after applying tests (a), (b), (c), (e) and (f), the circuits reported to be in contact test clear of fault, test (l) (Howler) should be applied to one circuit whilst the testing telephonist listens on the other circuit. There should be practically no "howler" sound heard if the two circuits are clear of fault.

Plugging-up cords (see Fig. 3). In the course of the normal exchange working there are always a number of faults which are due to subscribers wrongly operating their telephones and switching apparatus, and others due to inattention on the part of the subscriber when called by the exchange. There are also numerous cases when faults of other descriptions occur which necessitate plugging-up the circuit at the test position in order that it may be kept under supervision.

(36766)

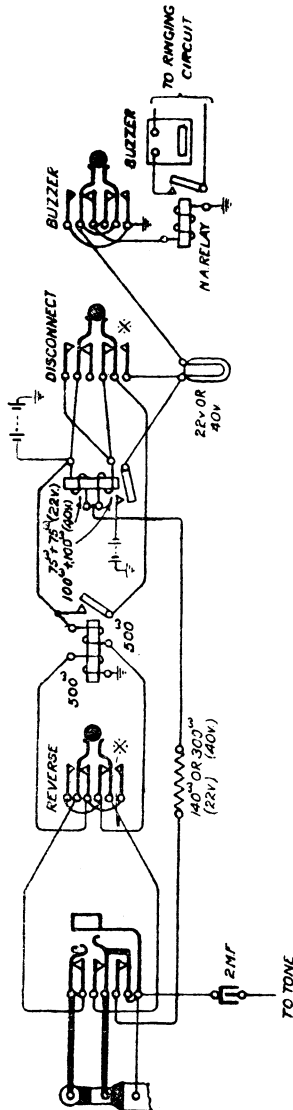
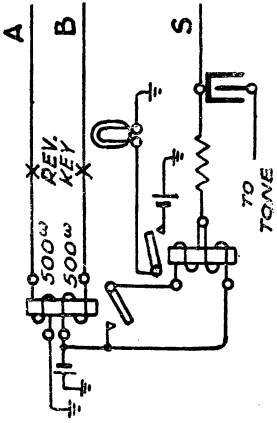
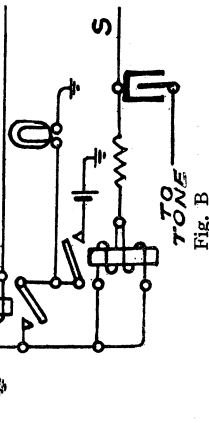

Fig. 3.—SUPERVISORY, TEST, AND PLUGGING-UP CIRCUITS.
(* Combined Key.)

The circuit shewn in Fig. 3 provides for the supervision of faulty circuits as follows:—

Nature of Faults.	Position of Control Key.	Circuit conditions established.
(1) Short circuit, receiver off, earth on <i>B</i> , receiving current on <i>A</i> line.	"Normal" (centre).	 <p>Fig. A</p>
(2) Earth on <i>A</i> line, receiving current on <i>B</i> line.	"Reverse"	<p>As above, except that the <i>A</i> and <i>B</i> line wires are reversed.</p>
(3) Disconnections	"Disconnect"	 <p>Fig. B</p>

In the case of (1) and (2), the disappearance of the fault will be signalled by the glowing of the lamp associated with the particular plugging-up circuit in use. In the case of (3), the disappearance of the fault will be indicated as above, but only when the subscriber removes his receiver to initiate a call. On receipt of the signal, the telephonist on the plugging-up position will take steps to verify the circuit conditions and restore the normal service.

The break-jack associated with each plugging-up circuit is for the purpose of allowing voltmeter tests to be carried out without removing the plug or disturbing the circuit connections on the line plugged up. An "out of order" tone is connected to the sleeve of these circuits.

For the purpose of gaining the attention of a subscriber who has left his receiver off the switch hook, a device known as a "Howler" is connected to a separate "Howler" cord circuit. The Howler consists of a special form of buzzer associated with an induction coil. Fig. 4 shows the connections of the complete circuit which is available for the use of the testing telephonist.

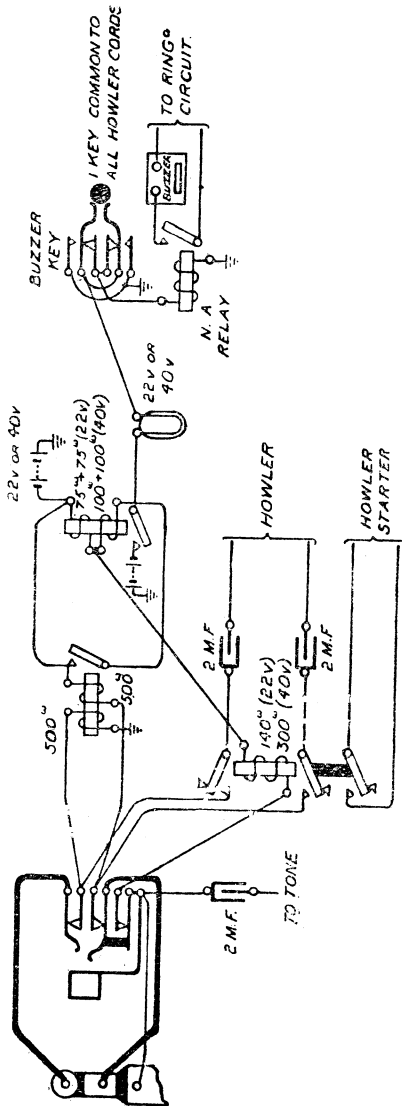

Fig. 4.—HOWLER CORD CIRCUIT.

The Howler is automatically applied when the plug is inserted in the multiple jack of a subscriber's circuit, and the lamp associated with the Howler cord will glow when the receiver is replaced. An "out of order tone" is connected to the sleeve circuit. **Before applying the "Howler," care should be taken in every case first to ascertain that no one is listening on the faulty circuit.**

In addition to the circuits mentioned in the foregoing the following circuits are provided:—Routine Testing circuit for subscribers' meters (Loose Leaf Diagram K.1709A) and Routine Testing circuit for sleeve circuits (Diagram K.1716 for 40 volt and K.1701A for 22 volt systems). These circuits are designed to ensure the accurate working of subscribers' meters. Further reference is made to these circuits in pamphlet D.16—Routine Testing for Telephone Exchanges.

GENERAL DESCRIPTION OF ENGINEER'S TEST DESK AND CIRCUITS.

Duties of Test Clerk.—The principal duties which a test clerk is called upon to perform are comprised in the following list:—

- (i) The testing of all circuits in respect of which a fault docket has been issued by the Traffic Staff.
- (ii) The control of the procedure to be adopted in the localisation and clearance of all faults.
- (iii) The distribution of fault work to the various responsible faultsmen.
- (iv) The co-operation with faultsmen in the clearance of faults.
- (v) The verification in every instance of the satisfactory condition of a circuit before the faultsmen leaves (includes speaking efficiency test).
- (vi) The entering of the necessary details on the fault cards and responsibility for the compilation of summary and analysis forms.
- (vii) The completion and care of the fault and other test-room card records.

Test Desk Equipment and Use of Circuits.—In addition to the equipment which is detailed later, each position of the desk is provided with fault card and docket sorting compartments, each compartment being numbered or otherwise designated for sorting purposes.

Each faultsmen is identified by a number corresponding to the fault section in which he is working, and fault cards similarly numbered are accommodated in the compartment bearing the assigned number, pending the clearance of the fault.

Twelve sorting compartments are provided on each position, but it is only in very exceptional cases that a test clerk has to deal with that number of faultsmen.

The circuits provided on the desk and the general purposes they serve are given in the following schedule :—

Note.—In the later issues of diagrams of test desks and test cases, the key numbers have been omitted.

The keys are now designated according to their functions and in addition given code letters, the code letters and designations on the diagrams appearing in proximity to the keys.

The keys on the face panels and face equipment drawings of test and test cases in connection with new installations will be similarly designated and code lettered.

The following schedule shows the code letters and designations which will be used :—

Fig. No.	Designation of Key.	Code Letters.
5	Ringling Direct and X	X
„	Ringling Y	Y
„	Howler	H
„	Line Reversing	R
„	Earthing	E
„	Voltmeter	V
„	Sounder	U
„	Cord Circuit Switching	CS
„	Speaking Test	T
„	Speaking	K
„	Earthing Plug Reversing	ER
„	Test Battery Cut-Off and receiving negative	N
„	Voltmeter Reversing	F
„	6v. Scale	L
„	Shunt 6v. Scale	S
„	Sounder Plug	SB
„	Holding Coil	O
„	Subs. Batt. and Holding Coil Cut off	B
„	Artif. Cable Change Over (34 miles)	AC
„	Artif. Cable (45 miles)	A
10	Hold	HC
„	Batty	BT
„	O. W. Ring Key	O.W. Ring
„	Ringling Key (Ans. Cord)	XA
„	Speaking Key	KC
„	Ring Key (Call Cord)	XC
„	Ringling and Speaking Key	XS and KS
11	Continuous Ringling	XR
„	Speaking	KR
„	Reversing	YR
13	Transmitter Cut-out	Z

Reference is made in pages 15, 23, 24, 27, 28,29, 30, 31, 32, 33, 34, 35, 36, 37 and 40 to key numbers, and where new installations are concerned, the code letters shown in the above schedule should be substituted for the key numbers referred to.

Test Desk Circuits.

Circuit Designation.	Object of Circuit.	Fig. No. (22-volt system only).
Test cord circuit	For complete testing of circuits, including speaking test over artificial cable	5
Interrupted earthing plug circuit	For use when testing two circuits reported to be in contact	5
Sounder plug circuit. (Note.—This circuit should not be used on loaded cables.)	For use when requiring :—(1) a heavy current to break down the resistance of a fault; (2) localisation of intermittent faults whenever an audible signal is required	5
Howler circuit	For gaining the attention of a subscriber who has left his receiver off the hook. The key in connection with this circuit is reversed to prevent accidental operation.	—
Test extension circuits to plugging-up position	For testing circuits <i>via</i> the multiple	6
Test extension circuits from plugging-up position	For extending to the desk circuits on which faultsmen desire to report the result of a fault investigation	7
Test extension circuit to last working "B" position of switchboard	For testing circuits <i>via</i> the "B" multiple	6
M.D.F. test and interception circuit	For testing lines at the M.D.F. and for intercepting circuits on which intermittent faults exist	8
Test circuit to test jacks ..	For testing circuits passing through test jacks	9
Speaking cord, connecting cord, and O.W. circuits	For general use in connection with the circuits on the desk	10
Ringing cord circuit ..	For continuous application of ringing current to a circuit for bell adjustments, etc.	11
Direct Exchange line ..	For ordinary Exchange service	—
Circuits to Exchange test position, monitor's desk, fitting bench, chief test clerk, etc.	For communications between the staff controlling the positions	—
O/G order wire circuits to test and plugging-up positions	For controlling the use of the test extension circuits	—
Test circuit to M.D.F. for lines under construction	For testing out new circuits before connecting to Exchange equipment	12
Telephone circuit	13
Night alarm circuit ..	—	—
Ringing distribution circuit	—	—
Line lamp pilot circuit ..	—	—

Test Cord, Interrupted Earth Plug and Sounder Plug Circuits.
 —These circuits terminate on switchboard plugs located in front of the test clerk. By means of the various testing circuits to the switchboard and M.D.F., the test clerk is able readily to connect his testing apparatus to any circuit in the exchange. A detailed description and an explanation of the use of these circuits is given later.

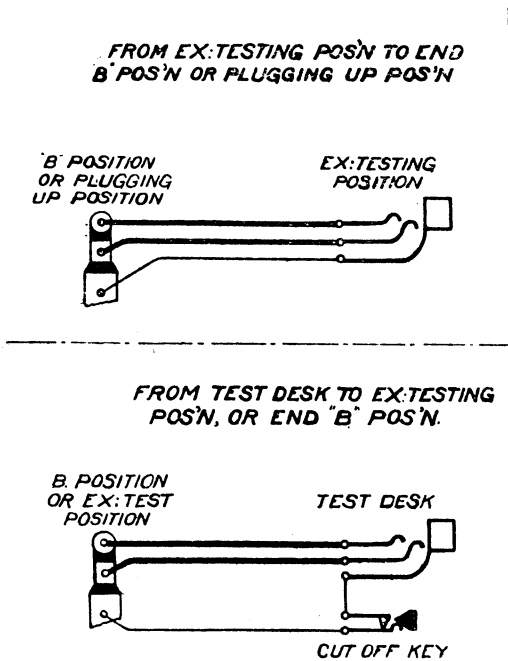

Fig. 6.

Test Extension Circuit TO the Test and Plugging-up Position.
 —The circuit terminates on a plug at the plugging-up position and is designed for the purpose of testing lines *via* the multiple, thus allowing a complete test to be made inclusive of switchboard wiring. At the test desk the circuit terminates on a jack with which is associated a "cut-off" key connected in series with the sleeve conductor. The depression of the C.O. key releases the cut-off relay of the subscriber's circuit under test. The key is used when the test clerk desires to call in the telephonist at the "A" position on which the circuit under test is terminated.

Approximately 90 per cent. of the tests on subscribers' circuits are made *via* the multiple, connection to any desired circuit being effected by the telephonist at the plugging-up position on a request being made by the test clerk over the order wire.

Upon the insertion of a test extension plug into a multiple jack on the switchboard, an "engaged test" is not given until the test clerk's plug is inserted into the test extension jack at the desk. A straight through circuit is thus obtained *via* the multiple and distribution frames to the subscriber's line, and tests may be carried out as desired. On completion of a test, the telephonist at the plugging-up position will be advised by order wire to withdraw the test extension plug. It will be observed that the circuit is so designed that if the plug at the switchboard is left inserted in a subscriber's jack and the test plug is withdrawn from the jack on the desk, the subscriber is able to call the exchange. *It is important that these circuits should be used only for tests originated by the test clerk.*

When carrying out tests *via* the test extension circuits the test clerk verifies, by calling in the "A" telephonist, that he is actually connected to the circuit reported on the docket.

**FROM EXCHANGE TESTING
POSITION TO TEST DESK**

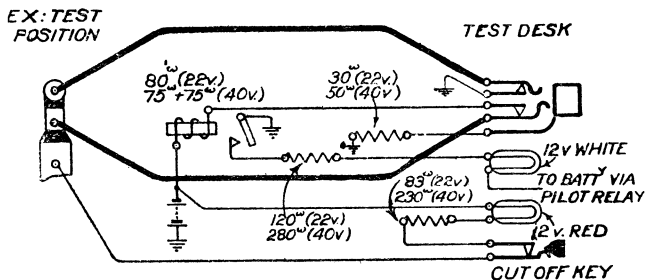

**MUST NOT BE INSTALLED UNLESS
THE TEST CLERK IS IN CONSTANT ATTENDANCE
AT THE TEST POSITION.**

Fig. 7.

Test Extension Circuit FROM the Test and Plugging-up Position.—This circuit is only installed at exchanges where a test clerk is constantly in attendance during the ordinary working hours. When a faultsman desires to communicate with the test clerk he will ask the "A" telephonist for "Test Clerk No." The particulars of the call are then passed over an order wire to the plugging-up telephonist who inserts a disengaged test extension plug, allocated to the use of the test clerk required, into the multiple jack of the circuit on which the call originated. The "A" telephonist will then withdraw her answering plug. The insertion of the test extension plug into a jack on the switchboard will cause the relevant red and white lamps on the test desk to glow, the red lamp indicating that the sleeve circuit is continuous and the white lamp that the "A" and "B" lines of the connected circuit are looped.

An "engaged" test is given immediately the test extension plug is inserted into the multiple jack of the line concerned, irrespective of whether there is a plug in the jack on the test desk or not.

It is important that these circuits be used for calls to the test clerk only during ordinary hours of duty.

Calls after working hours are completed *via* the direct exchange line which terminates on ordinary generator calling equipment at the desk. The calling subscriber is then able to "flash" in the "A" telephonist at the switchboard in case the test clerk is not in attendance. In these cases the operating staff should be informed as to the hours of attendance of the test room staff.

Calls for the test clerk from distant exchanges are completed *via* the circuits outgoing at the "B" positions and terminating on jacks at the plugging-up position. The plugging-up telephonist effects the connection by inserting a disengaged test extension plug, allocated to the use of the test clerk required, into the jack of the line from the "B" position.

A proportion of the calls from faultsman operating in the exchange area should be checked by the test clerk by calling in the "A" telephonist to verify that the tests are actually being carried out on the circuits reported to be faulty.

At exchanges where a test clerk is not in constant attendance and, consequently, where test extension circuits *from* the plugging-up position are not installed, all calls to the test clerk are set up by the plugging-up telephonist on receipt of a request from the "A" telephonist. The plugging-up telephonist effects the connection by means of an "A" cord

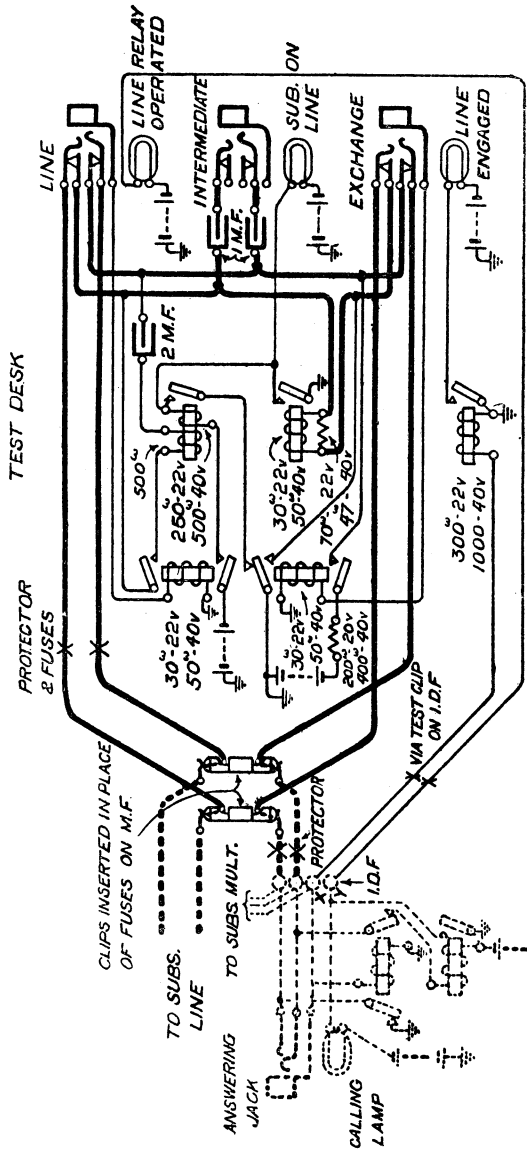

NOTE: THE CONNECTIONS ON THE I.D.F. AT X & Y WILL ONLY BE MADE WHEN THE NATURE OF THE FAULT NECESSITATES PROLONGED OBSERVATION

Fig. 8.

DOTTED PORTION SHOWS SUBSCRIBERS REGULAR EQUIPMENT

circuit *via* the ordinary exchange line to the test desk. When the test clerk desires to make a test on a circuit which has been so extended, he orders up the connection on a test extension circuit (Fig. 6) in the usual way. The plugging-up telephonist then replaces the "A" cord circuit plug by the test extension plug.

Main Frame Test—Interception Circuit.—This is a combined test-interception circuit and by its use a test clerk can intercept any circuit at the line side of the M.D.F. Double plug-ended test cords are used at the M.D.F. for extending to the test desk the line and exchange sides of the circuit under test.

When necessary for purposes of observing the working of a circuit, a connection to the lamp and sleeve wires of the intercepted circuit are made at the I.D.F. by means of the test clips, plugs and jacks provided.

For ordinary testing purposes the circuit operates as follows :—

Normally, the circuit extended to the desk is in a "through" condition and if there is a "loop" on the line the lamp labelled "sub. on line" will glow, due to the operation of the supervisory relay in series with the *A* line. Upon the insertion of the test plug into either the "line" or "exchange" jacks, calling equipment is automatically connected to the side of the circuit not under test. The "sub. on line" lamp will glow if a call be made on that side of the circuit not under test. The "intermediate" jack is provided for bridging-in purposes.

When a connection is also made to the subscriber's circuit at the I.D.F. the lamps labelled "Line relay operated" and "Line engaged" respectively, are brought into use, the first named being connected in parallel with the subscriber's ordinary calling lamp on the switchboard and the latter being connected to a relay which is in parallel with the subscriber's cut off relay. When a plug is inserted into the subscriber's answering or multiple jack on the switchboard, the "line engaged" lamp will glow if the sleeve circuit is continuous. By means of these lamps the progress of a call can be followed and any failure of the subscriber's circuit apparatus readily detected.

The test clerk is responsible for ensuring that plugs are not left inserted in the jacks when the test desk is vacated at night. With the exception of circuits under observation, all circuits should be restored to their normal working conditions at the end of the day, heat coils and fuses being replaced.

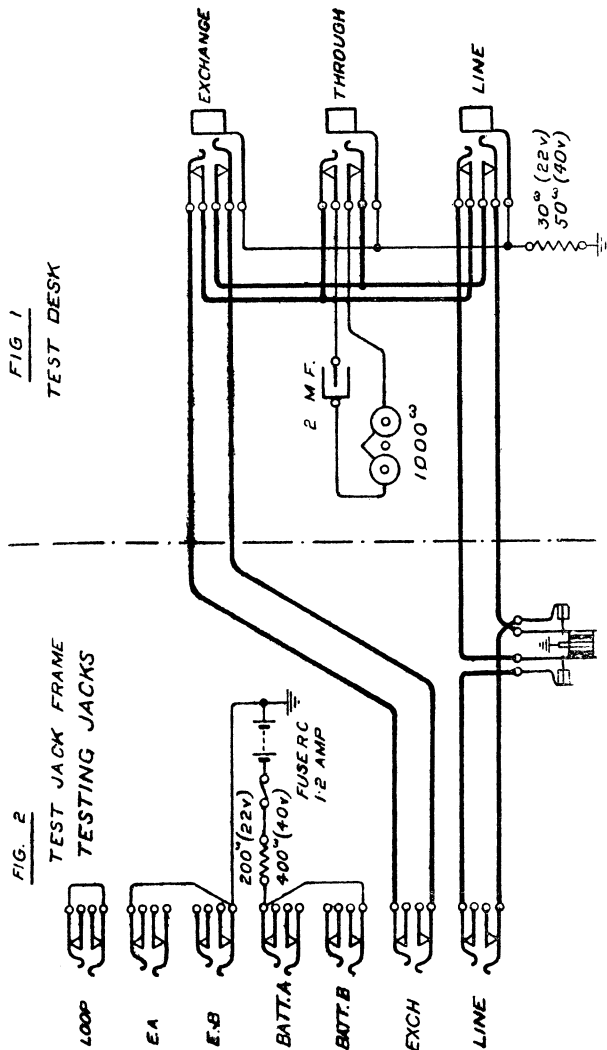

Fig. 9.

Test Circuit to Test Jack Frame.—This circuit is for the purpose of allowing tests to be carried out on circuits connected to jacks at the test jack frame.

Three jacks are provided on the circuit at the desk, labelled "Exchange," "Line" and "Through" respectively. The first two jacks are connected to two similarly labelled jacks on the test jack frame, double plug-ended cords being used for effecting connection between the test circuit and both sides of the line required for test.

The "Through" jack is for bridging-in purposes. Inserting the test cord circuit plug into either the "Exchange" or "Line" jacks connects the test clerk's testing equipment to one side of the circuit, whilst the side not under test is connected to a 1000 ω bell and condenser on the desk.

Testing facilities for use in conjunction with Trunk and other circuits passing through test jacks are provided at C.B. Exchanges and the connections of the special jacks are shown in Fig. 9.

Double plug-ended 2-way cords are used for connecting the special jacks as requested by a distant testing station as follows :—

To disconnect.—Insert one plug into jack of line under test and let other plug remain free and insulated.

To "loop."—Insert one plug into jack of line under test and other plug into jack labelled "loop."

To earth the A wire.—Insert one plug into jack of line under test and other plug into jack labelled EA.

To earth the B wire.—Insert one plug into jack of line under test and other plug into jack labelled EB.

To connect battery to A line.—Insert one plug into jack of line under test and other plug into jack labelled "BATT. A."

To connect battery to B line.—Insert one plug into jack of line under test and other plug into jack labelled "BATT. B."

Speaking Cord and Connecting Cord Circuits.—These cord circuits are provided for general use in connection with the miscellaneous jack-ended circuits on the desk.

The *Speaking Cord* has a 600 ω coil permanently connected across the speaking side of the key. The circuit is used in cases where it is desired to "hold" a line whilst the test clerk carries out tests on another circuit and also for speaking to Monitor or "A" telephonist, etc., *via* the lines to and from the switchboard.

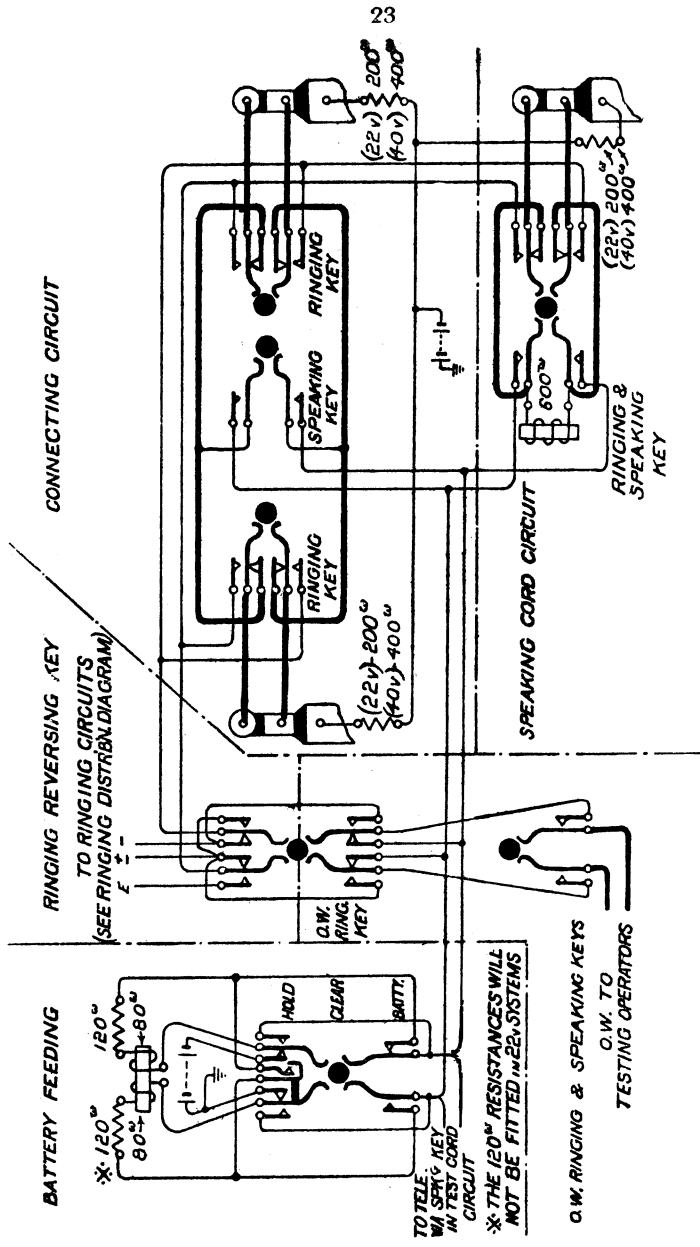

Fig. 10.

To speak to a faultsman *via* the test extension lines it is necessary to throw the "battery" key in order to supply current for talking purposes. The "speaking" and "battery" keys should be replaced in their normal positions when the Speaking Cord circuit is not in use. A ringing key is provided for ringing purposes when required.

The *Connecting Cords* consist of a pair of straight through cords without any supervisory apparatus, a ringing key being provided for each plug and one speaking key for listening-in purposes. To "hold" a line, or to connect "battery" for talking or signalling purposes in connection with C.B. circuits, the "hold" or "battery" key should be manipulated as required.

Unless the speaking key No. 14 associated with the test cord circuit (Fig. 5) is in the normal position, the speaking keys on the miscellaneous cord circuits cannot be used, as the test clerk's telephone circuit is wired *via* the inner springs of key No. 14.

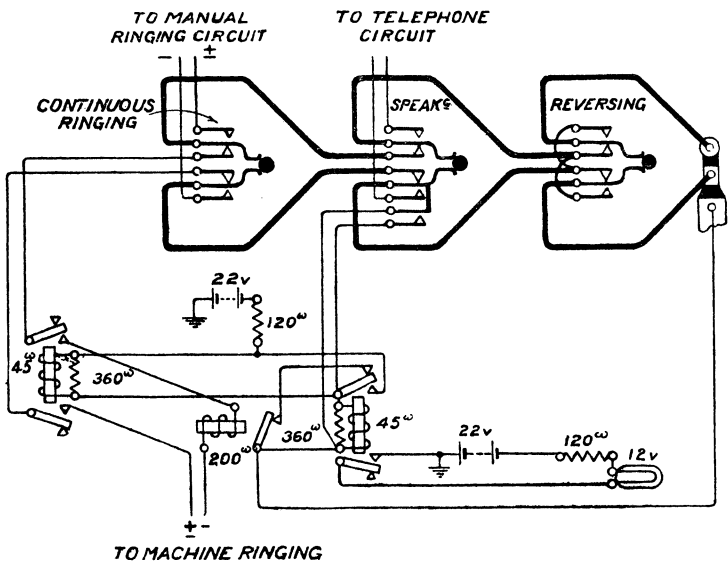

Fig. 11.

Ringling Cord Circuit.—This circuit, which terminates on a plug on the test desk, is designed to operate either as a keyless ringing circuit or a manual ringing circuit, and is intended to be used when a faultsman requires ringing current for bell adjustments, etc. Current for talking purposes is obtained by throwing the "battery" key associated with the Speaking and Connecting Cords.

When the keys on the ringing cord circuit are in the normal position the insertion of the ringing cord plug into a jack on the desk immediately connects interrupted ringing current to the *A* and *B* wires of the circuit. The removal of the subscriber's receiver actuates a tripping relay which disconnects the ringing current as in the case of an ordinary keyless ringing junction circuit, at the same time causing a lamp to glow on the test desk.

When it is desired to send out uninterrupted ringing current, the "continuous ringing" key is thrown. The key is a locking key and should therefore be restored by hand when the ringing current has to be disconnected.

Direct Exchange Line.—This circuit, which terminates on subscribers' calling equipment at an "A" position, is an ordinary exchange connection and is used for miscellaneous incoming and outgoing calls. The "Speaking" cord circuit shown in Fig. 10 is used for operating this line.

Lines to Exchange Test Position, Monitor's Desk, etc.—These circuits are used for intercommunication between the test clerk and the testing telephonist, monitors, etc., as required. The *A* and *B* lines are reversed in order that the battery on the test clerk's test cord circuit, when used on these circuits, will not oppose the battery on the switchroom cord circuits and thereby prevent the actuation of the supervisory relays.

Outgoing Order Wire Circuits.—The order wire circuits to the test and plugging-up positions of the switchboard are provided for the purpose of ordering up and clearing the circuits required for test *via* the test extension lines.

Test Circuit to M.D.F. for New Lines.—These circuits are provided for the purpose of facilitating the joining up of new subscribers' lines. The cable pairs allocated for the new subscribers are connected by means of the test clips and cords to the appropriate jacks on the line side of the M.D.F., which are wired to jacks on the test desk.

When the connected line is "looped" at the distant end, the lamp on the desk glows and the test clerk may carry out tests by inserting his test plug into the relevant jack. If there is no one on the line the test clerk depresses the key associated with the circuit concerned, thus locking out the line relay and lamp until the "loop" is removed, when the normal connections are restored automatically and the attention of the test clerk can then be obtained in the standard way.

"Tone" is provided on the circuit to enable the workman to identify it readily when dealing with a number of circuits.

Before a workman leaves the premises of a subscriber to which a new line has been connected, the test clerk measures the loop resistance of the circuit and records the result on the fault card for future reference. The test is made by means of the ordinary voltmeter equipment. The subscriber's earth connection is tested at the same time. The resistance to earth must only slightly exceed half the loop resistance.

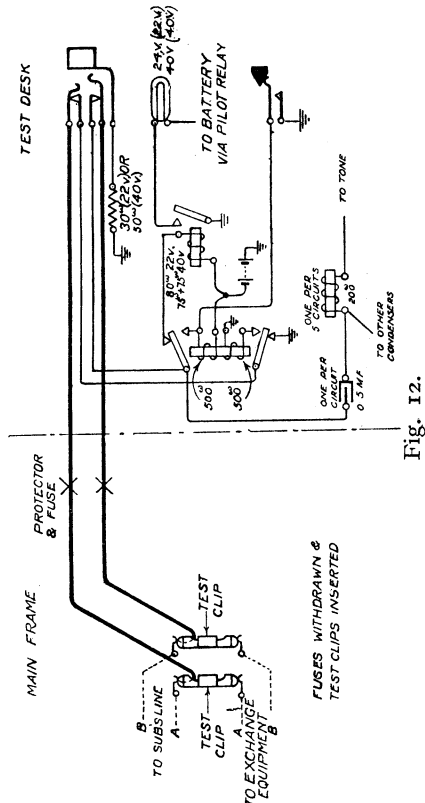

Fig. 12.

DETAILED DESCRIPTION OF TEST CORD CIRCUIT.

(See Fig. 5.)

When all the test keys are in the normal (*i.e.*, centre) position, the circuit is equivalent to an ordinary "A" position

cord circuit. When connected to a subscriber's line the actuations of the subscriber's switch hook will cause the supervisory lamp on the desk to flash in the usual manner.

The telephone for the test clerk's use is connected in series with a condenser, and by throwing the "Speaking" key (No. 14) it is connected to the test cord through the equivalent of an "A" or "B" cord circuit according to the position of the "Cord circuit switching" key (No. 11).

In order to gain the attention of an "A" telephonist when testing the exchange side of a subscriber's circuit *via* the M.D.F. test-interception circuit (see Fig. 5), the "Holding coil" key (No. 15) should be thrown. When testing *via* the multiple, the C.O. key of the test extension circuit in use for the test should also be depressed in order to release the subscriber's cut-off relay. To listen on a circuit without interfering with the signalling conditions, the "Subscriber's battery and Holding coil cut-off" key (No. 12) should be thrown in conjunction with the "Speaking" key (No. 14), all other keys remaining in the normal position.

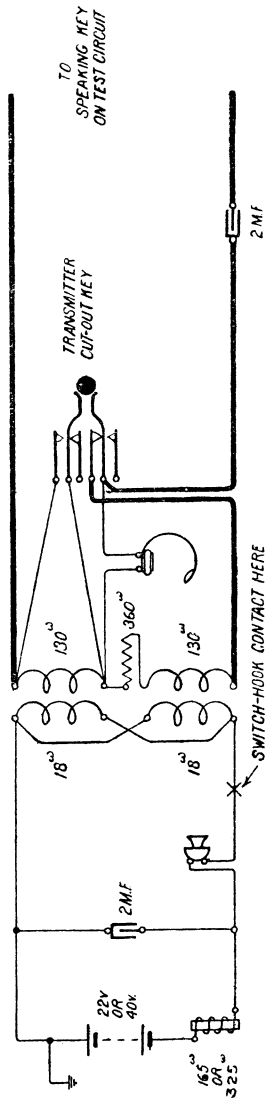

Fig. 13.

The following schedules indicate the functions of the different keys in the test cord circuit and miscellaneous cord circuits on the desk :—

Test Cord Circuit Keys. (See Figs. 5 and 10.)

Key Numbers, Designations, and Functions.

No. 1. **Ringng Direct and X.**—For ringing ordinary and “ X ” party line subscribers. Connects ringing current to the *A* line and battery to the *B* line.

No. 2. **Ringng Y.**—For ringing “ Y ” party line subscribers. Connects ringing current to the *B* line and earth to *A* line.

No. 5. **Howler.**—For gaining the attention of a subscriber who has left his receiver off the hook. *Before applying the “ Howler ” care should be taken in every case first to ascertain that there is no one listening on the circuit.*

No. 7. **Line Reversing.**—For reversing the *A* and *B* lines.

No. 8. **Earthing.**—For earthing the *A* line of a circuit under test, or in conjunction with the “ Line reversing ” key (No. 7) for earthing the *B* line.

No. 9. **Sounder.**—For use when requiring a heavy current to break down a fault and for assisting in the localisation of faults when an audible signal is required. Connects an 80^Ω relay and exchange battery to the *B* line. *A* line left disconnected.

No. 11. **Cord Circuit Switching.**—For testing lines under actual working conditions. Changes over the circuit conditions from the equivalent of an “ A ” cord circuit to those of a “ B.”

No. 12. **Subs. Battery and Holding Coil C.O.**—For use when speaking on a circuit not requiring battery current or a loop from the test desk. Disconnects the battery feed and holding coil from the test cord circuit.

No. 13. **Speaking Test.**—For use when carrying out a speaking efficiency test through the artificial cable. Used in conjunction with the artificial cable keys (No. 43 and 44) common to a 2-position desk.

No. 14. **Speaking.**—For use when the test clerk desires to speak on the circuit under test. Connects the test clerk’s telephone to the test cord circuit. (This key must be in the normal position when the test clerk desires to speak on any other cord circuit on the desk.)

No. 15. **Holding Coil.**—For “calling” or “holding” purposes on exchange circuits. Disconnects battery feed and connects holding coil across the test cord circuit.

No. 17. **Voltmeter.**—For use in general testing. Connects voltmeter and test battery to the *B* line and disconnects *A* line.

No. 18. **6-Volt Scale.**—For use in conjunction with “Voltmeter” key (No. 17) for conductivity tests. Changes the scale reading of the voltmeter and the voltage of the testing battery from 60 to 6.

No. 19. **Shunt 6-Volt Scale.**—For use in conjunction with “Voltmeter” and “6-Volt scale” keys (No. 17 and 18) for measuring conductor resistances. Connects a $\frac{1}{10}$ th shunt across the 6-volt coil of the voltmeter.

No. 21. **Test Batt. C.O. and Receiving Negative.**—For testing for stray negative currents. Disconnects testing battery and connects the negative terminal of the voltmeter to the *B* line of the circuit under test, and the positive terminal to earth.

No. 22. **Voltmeter Reversing.**—For use when testing for “received currents” in conjunction with “Test battery C.O. and Receiving Negative” key (No. 21). Reverses the connection of the voltmeter.

No. 24. **Earthing Plug Reversing.**—For use with the earthing plug. With the key in normal position the *B* line of the earthing plug is connected to an interrupted earth and, when key is thrown, the *A* line is connected to interrupted earth.

No. 25. **Sounder Plug Reversing.**—For use with the sounder plug. With key in normal position the sounder relay is connected to *B* line and an earth to *A* line. When key is thrown the connections are reversed.

No. 31. **Transmitter Cut Out.**—For use when desiring to cut out the transmitter noise during a listening test. Disconnects secondary of induction coil and connects test clerk’s receiver and condenser only across cord circuit.

No. 32. **Battery, Clear, Hold.**—For use in conjunction with the “Connecting” and “Ringing” cord circuits. In the normal position, *i.e.*, “Clear,” battery feed and holding coil are disconnected. In the position marked “Battery” the battery feed is connected *via* a retardation coil. In the “Hold” position a holding coil is connected across the circuit.

Test Cord Circuit. (See Fig. 5.)

KEYS TO BE OPERATED IN CONDUCTING THE VARIOUS TESTS.

(Where not otherwise stated the tests are to be made in conjunction with the test plug on the test cord circuit).

Test.	Fault tested for.	Designation and numbers of the keys to be operated.	Observed result if the fault exists.
(a)	Earth on "B" (60-volt test)	Key 17 (voltmeter)	Voltmeter deflection in excess of figure specified by engineer.
(b)	Earth on "A" (60-volt test)	Key 7 (line reversing) and key 17 (voltmeter)	
(c)	Loop or s/c (60-volt test)	Keys 8 (earthing) and 17 (voltmeter)	
(d)	Loop or s/c (6-volt test)	Keys 8 (earthing), 17 (voltmeter), and 18 (6-volt scale)	
(e)	Loop or s/c (6-volt test with shunted voltmeter)	Keys 8 (earthing), 17 (voltmeter), 18 (6-volt scale), and 19 (shunt 6-volt scale)	
(f)	Disconnection	Keys 8 (earthing) and 17 (voltmeter)	Do. do. If test indicates that subscriber's receiver is off the hook, "Howler" key (No. 5) should be operated, after first ascertaining that no one is listening on the circuit under test.
(g)	Receiving <i>negative</i> current on "B"	Keys 17 (voltmeter) and 21 (test battery C.O. and receiving negative)	No deflection or deflection within limit specified by engineer. If "reversing" key (No. 7) is also operated several times when a subscriber's circuit is under test, the absence of a "throw" from condenser discharge on the voltmeter needle indicates a disconnection.
(h)	Do. on "A"	Keys 7 (line reversing), 17 , and 21 ...	
(i)	Receiving <i>positive</i> current on "B"	Keys 17 , 21 , and 22 (voltmeter reversing)	
(j)	Do. on "A"	Keys 7 , 17 , 21 , and 22	

Deflection will be obtained on voltmeter. If a readable deflection be not obtained, operate key No. **18** to utilise the more sensitive low voltage scale.

(k)	Intermittent earth on "B" or intermittent s/c	Insert sounder plug only
(l)	Intermittent earth on "A" or intermittent s/c	Insert sounder plug and throw key 25 (sounder plug reversing)
(m)	Contact between "B" lines of two circuits (<i>see</i> footnote)	Insert sounder and earthing plugs only ..
(n)	Do. do. "A" lines	Do. do. and throw keys 24 (earthing plug reversing) and 25 (sounder plug reversing)
(o)	Contact between "A" line of one circuit and "B" line of another circuit (<i>see</i> footnote)	Insert sounder and earthing plugs and throw key 25 (sounder plug reversing)
(p)	Contact between two circuits (voltmeter method)	Throw key 17 (voltmeter) and insert test plug into one jack and earthing plug into other jack of circuits under test. If a "loop" cannot be obtained on each of the two circuits, also operate keys 7 , then 7 and 24 , then 24
(q)	Overhearing between two circuits (cross-talk)	Insert test plug into one jack and "speaking" plug into other jack of circuits under test. Throw "speaking cord" key (No. 33) and "howler" key (No. 5)
(r)	Speaking to a subscriber	Throw key 14 (speaking) only
(s)	Speaking to Exchange	Throw keys 14 (speaking) and 15 (holding coil)
(t)	Speaking efficiency	Throw keys 13 (speaking test) and 14 (speaking)
(u)	Noise under junction circuit conditions	Throw keys 11 (cord circuit switching) and 14 (speaking)

The sounder will give an audible signal and sounder lamp will glow.

An interrupted deflection on the voltmeter will be obtained.

"Howler" will be heard.
Note.—Before applying the "Howler, throw key **14** (speaking) and ascertain that no one is listening on circuit to which the test plug is connected.
 Use key **1** (ringing direct and X) or **2** (ringing Y) for ringing the subscriber.

The artificial cable switching keys (No. **43** and **44**) should also be thrown if necessary, the latter only when 45-mile test is required.

Note. In tests (m), (n), and (o) it is assumed that the circuit to which the sounder plug is connected is not "looped" at any point.

No. 33. **Ringling and Speaking.**—For use in conjunction with "Speaking" cord. A 600^Ω coil is connected across the circuit when the key is in normal position or when speaking key is operated. The non-locking side of the key connects ringing current to the circuit, and disconnects holding coil.

No. 34, 35 and 36. **Ringling and Speaking.**—For use in conjunction with "Connecting" cords. A ringling key is provided for each plug. The speaking key (No. 35) connects the cords to the "Battery, Clear, and Hold" key (No. 32) and to the test clerk's telephone circuit.

No. 37. **Order Wire Ringling.**—For use in conjunction with the O.W. keys.

No. 38. **Ringling Reversing.**—For use in conjunction with "Speaking" and "Connecting" cord circuits. Reverses the connections of the ringling circuit.

No. 39. **Continuous Ringling.**—For use in conjunction with "Ringling" cord circuit. Connects uninterrupted ringling current to *A* line and battery to *B* line.

No. 40. **Speaking.**—For enabling test clerk to speak on "Ringling" cord circuit. Connects test clerk's telephone across cord and trips ringling.

No. 41. **Reversing.**—For reversing ringling on "Ringling" cord circuit.

No. 43. **Artificial Cable Changeover. 34 miles.** (Common to two-position desk.)—For use in conjunction with test cord circuit keys 13 and 14 when carrying out speaking efficiency tests. In the normal position of the key, 34 miles of standard cable is connected to the left hand test desk position. When thrown the 34 miles of cable is connected to the right hand position.

No. 44. **Artificial Cable. 45 miles.** (Common to two-position desk.)—Used in conjunction with test cord circuit keys 13 and 14 when it is desired to speak on a line through 45 miles of standard cable. The ordinary D.P. Receiver on the desk supplements the test clerk's H.G. Receiver when the 45 miles of cable is in use. In the operated position key No. 44 connects an additional 11 miles of standard cable to the 34 miles and brings into circuit a 60^Ω D.P. Receiver when removed from the switchhook.

Figs. 14 to 21 inclusive illustrate diagrammatically the connections of the Test Desk test cord when carrying out certain tests as specified in the foregoing table.

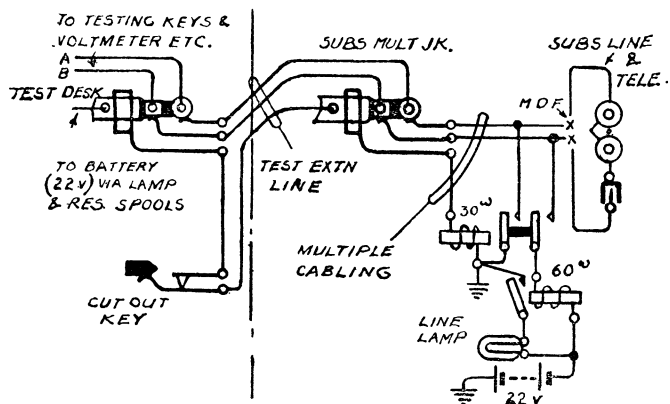

Fig. 14.—CONNECTIONS WHEN TESTING A LINE *via* A TEST EXTENSION LINE FROM THE TEST DESK.

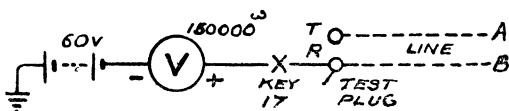

Fig. 15.—TEST FOR EARTH OR LOW INSULATION ON "B" LINE.

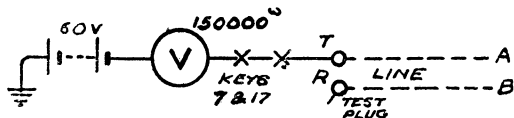
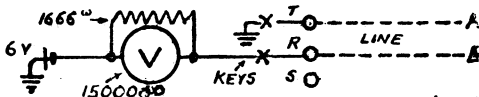

Fig. 16.—TEST FOR EARTH OR LOW INSULATION ON "A" LINE.



The same test can be made with the 60V Batt. & unshunted 150000^Ω voltmeter by using KEYS 17 & 18 only

Fig. 17.—TEST FOR LOOP OR SUBS. RECR. OFF OR S/C (6 VOLT TEST WITH SHUNTED VOLTMETER).

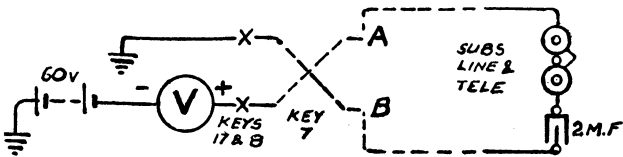

Fig. 18.—TEST FOR DISCONNECTION ON SUBS. LINE CCT. (VOLTMETER "KICK METHOD") WITH KEYS 17 AND 8 THROWN, OPERATE THE LINE REVERSING KEY (No. 7) TWO OR THREE TIMES QUICKLY.

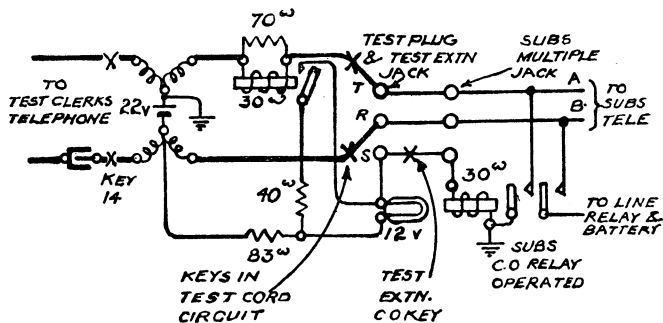

Fig. 19.—CONNECTIONS OF TEST CORD CCT. WHEN SPEAKING TO C.B. SUBS. [THROW SPEAKING KEY (No. 14.)

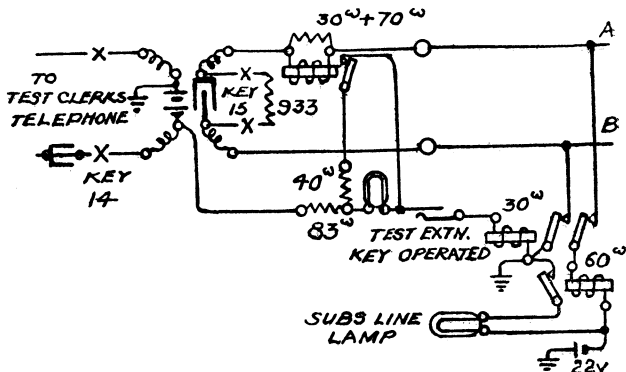

Fig. 20.—CONNECTIONS OF TEST CORD CIRCUIT WHEN HOLDING A LINE OR CALLING IN THE "A" TELEPHONIST DURING A TEST ON A SUBS. LINE. (THROW KEYS 15 AND 14 AND DEPRESS CUT OUT KEY ON TEST EXTN. LINE IN USE FOR TEST.)

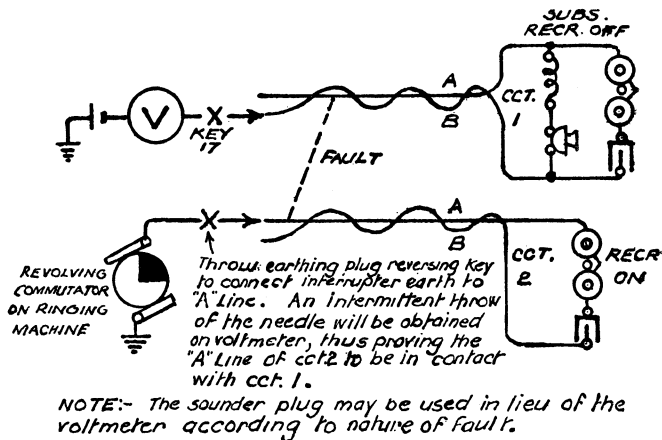

Fig. 21.—TEST FOR CONTACT BETWEEN ONE CIRCUIT AND ANOTHER (USING VOLTMETER AND INTERRUPTED EARTH PLUG).

Contact Tests. Voltmeter Tests for contacts on subscribers' circuits are generally made with the subscriber's receiver off the hook, the voltmeter and test battery being applied to one circuit whilst an interrupted earth is connected to the other circuit (see Fig. 21).

Speaking Efficiency Tests. In order to carry out this test a "Cable, Artificial, 34 + 11" is provided on the test desk, and by the operation of the "Speaking Test" and "Speaking" keys (No. 13 & 14) in the test cord circuit and the relevant cable switching keys (No. 43 & 44) common to the desk, the test clerk can connect in circuit 34 or 45 miles of artificial cable.

Generally, all speaking efficiency tests are made with 34 miles in circuit, but in exceptional cases, *e.g.*, when a subscriber complains of defective transmission over trunk circuits, the severer test of 45 miles is applied. In the latter case it is essential that silent conditions prevail at the two ends of the circuit and a "Bell" receiver is provided on the desk which, in conjunction with the test clerk's headgear receiver, assists in obtaining these conditions. The "Bell" receiver cannot be used on the 34 mile cable.

Particulars of Voltmeter. The Voltmeter associated with the test cord circuit on the latest type of desks is of the D'Arsonval deadbeat type and has two scales, one reading from 0 to 60 and the other from 0 to 6. The resistance between the terminals is 150,000 ω for the 60 volt and 15,000 ω for the 6 volt calibration. The moving coil of the voltmeter has a resistance of 1,000 ω and the sensitivity of the instrument is such that a current of 0.4 milliampères gives a full scale of deflection. For further details of the construction of this type of voltmeter see Workman's Pamphlet A. 6.

A one-tenth shunt (1,666 ω) is associated with Key No. 19 (shunt 6-volt scale), and shunts the 15,000 ω circuit of the voltmeter.

The voltmeter is provided with an index pointer which can be set to any position on the scale. This is used in cases where a standard deflection is decided upon and the object of the test is to determine whether the resistance of the circuit under test is greater or less than the standard.

Test Battery. Two voltages are provided for testing purposes, *viz.*, 6 and 60, the former obtained from a battery of 4 primary cells common to a two position desk. The 60 volts for insulation testing purposes is obtained from a battery of 43 primary cells, and this battery usually serves all the test desk positions.

Resistance Measurements. The resistances corresponding to the voltmeter deflections when the voltage of the test battery is 6 and 60 respectively are shown in the " Resistance chart for voltmeter " at the end of this pamphlet.

When it is desired to obtain a higher degree of accuracy or when the testing voltage differs from the standard figure, the following formula should be used :—

$$R = V \left(\frac{D}{D_1} - 1 \right)$$

where R = resistance under test.

V = resistance of voltmeter.

D = deflection obtained when the test plug is inserted into a short circuited jack on the desk and relevant keys operated.

D_1 = deflection obtained when resistance under test is in circuit.

Generally when the resistance to be measured :—

- (1) Exceeds $45,000\omega$ the 60-volt scale is used.
- (2) Exceeds $4,500\omega$ and does not exceed $45,000\omega$ the 6-volt scale unshunted is used.
- (3) Is less than $4,500\omega$ the 6-volt scale and one-tenth shunt is used.

Conductivity Tests. In testing lines for conductor resistance three conditions have to be met as follow :—

- (i) " A " line earthed at distant end (Operate Keys 17, 18, 19 & 7).
- (ii) " B " line earthed at distant end (Operate Keys 17 18 & 19).
- (iii) " A " & " B " lines looped at distant end (Operate Keys 17, 18, 19 & 8).

Before making tests (i) and (ii) it should be ascertained by means of tests for receiving current that the deflection is not due to potential difference between the earth at distant end and testing earth.

RESISTANCE CHART FOR VOLTMETER, 0-6 & 0-60.

If the 15,000 coil has been used with LOW VOLTAGE and SHUNT, the RESISTANCE is as in the Table.
 " 15,000 " " " without " " " 10 times " "
 " 150,000 " " " " " " " " 100 " " "

FORMULA.— $R = V(D/D_1 - 1)$, where V = Resistance of Voltmeter = 1,500 when shunt is in use.
 " D = Deflection when Voltmeter is across battery only.
 " $D_1 =$ " " external resistance R is in series with Voltmeter and battery.

D104
21/10/19.
Sheet 1.

Deflection. (D_1)	Value of R when D equals					Deflection. (D_1)	Value of R when D equals				
	60.	59.	58.	57.	56.		60.	59.	58.	57.	56.
0-0	178500	175500	172500	169500	166500	30-5	1500	1450	1400	1350	1300
1-5	88500	87000	85500	84000	82500	31-5	1400	1355	1306	1258	1214
2-0	43500	42750	42000	41250	40500	32-5	1310	1265	1219	1172	1127
3-0	28500	28000	27500	27000	26500	33-5	1228	1182	1136	1091	1047
4-0	21000	20625	20250	19875	19500	34-5	1147	1103	1059	1015	978
5-5	14850	14590	14320	14050	13780	35-5	1070	1029	986	943	908
6-0	13500	13250	13000	12750	12500	36-5	1000	958	916	875	834
7-5	11350	11140	10930	10720	10510	37-5	935	892	851	811	770
8-5	9750	9565	9375	9190	9000	38-5	868	829	789	750	720
9-5	8500	8330	8165	8000	7835	39-5	810	769	730	692	664
10-5	7500	7350	7200	7050	6900	40-5	750	712	675	639	611
11-5	6875	6740	6605	6470	6335	41-5	695	658	622	585	560

12^o	6000	5875	5750	5625	42^o	645	607	571	535
	5700	5580	5460	5340		620	582	547	511
13^o	5420	5310	5195	5080	43^o	585	558	523	488
	5180	5055	4945	4830		570	535	500	465
14^o	4925	4820	4715	4610	44^o	545	511	477	442
	4710	4605	4500	4395		522	488	454	421
15^o	4500	4400	4300	4200	45^o	500	467	434	400
	4310	4210	4110	4015		478	445	412	379
16^o	4120	4035	3935	3845	46^o	457	427	391	358
	3950	3885	3775	3680		436	403	370	338
17^o	3780	3705	3615	3530	47^o	415	383	351	319
	3640	3555	3470	3385		396	363	331	300
18^o	3500	3415	3330	3250	48^o	373	344	312	281
	3370	3285	3200	3120		356	325	294	263
19^o	3120	3160	3080	3000	49^o	337	308	275	244
		3040	2960	2885		318	288	256	225
20^o	3000	2925	2850	2775	50^o	300	270	240	210
	2885	2815	2745	2670		282	252	222	193
21^o	2785	2715	2645	2570	51^o	265	235	208	176
	2685	2615	2550	2475		248	218	189	160
22^o	2595	2525	2455	2385	52^o	231	202	173	144
	2500	2435	2365	2300		214	185	157	129
23^o	2410	2350	2285	2220	53^o	198	170	141	113
	2330	2265	2200	2135		182	154	126	98
24^o	2250	2190	2125	2065	54^o	167	139	111	83
	2170	2115	2050	1990		152	124	96	69
25^o	2100	2040	1980	1920	55^o	137	109	82	54
	2030	1970	1910	1850		122	95	68	41
26^o	1982	1905	1845	1785	56^o	107	80	53	27
	1895	1840	1785	1725		93	66	40	14
27^o	1830	1760	1720	1665	57^o	79	53	27	—
	1775	1720	1665	1610		65	39	13	—
28^o	1715	1660	1605	1555	58^o	51	26	—	—
	1660	1605	1550	1500		38	13	—	—
29^o	1600	1550	1500	1450	59^o	26	—	—	—
	1550	1500	1450	1400		13	—	—	—

Where an incoming current is not received the deflections in the case of tests (i) (ii) and (iii) can be interpreted in terms of ohms by reference to the "Resistance chart for voltmeter" at the end of this pamphlet.

Where an incoming current is received it will be necessary to compute the resistance on the following basis:—

Set the keys for "Receiving negative current" and note the deflection (d), then

$$R = V \left(\frac{D}{D_1 + d} - 1 \right)$$

If the deflection when the keys are set for "Receiving negative currents" is in the opposite direction to the scale readings, the "voltmeter reversing" key (No. 22) should be thrown in order to bring the deflection on to the scale; then

$$R = V \left(\frac{D}{D_1 - d} - 1 \right)$$

Insulation Tests. In testing for insulation resistance of "A" or "B" wires the distant end of the line should be disconnected. If the "A" wire of the pair under test is required to be connected to earth, throw "Earthing" key (No. 8) (*see* Figs. 15 and 16).

Ballistic Tests. The capacity of a line and any condensers connected to it, can be tested by means of the voltmeter. The voltmeter is so constructed that the sudden reversal of the charge at a potential of 60 volts of the 2 mf. condenser in the bell circuit of a subscriber's telephone, will cause the needle to be thrown to a point near the centre of the scale. To make this capacity test the "voltmeter" and "earthing" keys must first be thrown, then the "line reversing" key must be operated quickly several times, a "throw" of the needle occurring at each reversal. In the case of a bell and condenser connected from one side of a subscriber's line to earth, the "throw" will be equal to about one-half the "throw" obtained with the condenser and bell bridged across the line. This is due to the fact that in the former case there is no reversal of the charge in the condenser.

== LIST OF ==
Technical Pamphlets for Workmen.

(Continued.)

GROUP E.

1. Automatic Telephony. Step by Step Systems.
2. Automatic Telephony. Coder Call Indicator (C.C.I.) Working.
3. Automatic Telephony. Keysending " B " positions.

GROUP F.

1. Subscribers' Apparatus C.B.
2. Subscribers' Apparatus C.B.S.
3. Subscribers' Apparatus Magneto.
4. Private Branch Exchange—C.B.
5. Private Branch Exchange—C.B. Multiple, No. 9.
6. Private Branch Exchange—Magneto.
7. House Telephones.
8. Wiring of Subscribers' Premises.

GROUP G.

1. Secondary Cells, Maintenance of.
2. Power Plant for Telegraph and Telephone Purposes.
3. Maintenance of Power Plant for Telegraph and Telephone Purposes.
4. Telegraph Battery Power Distribution Boards.

GROUP H.

1. Open Line Construction, Part I.
2. Open Line Construction, Part II.
3. Open Line Maintenance.
4. Underground Construction, Part I.
5. Underground Construction, Part II.
6. Underground Maintenance.
7. Cable Balancing.
8. Power Circuit Guarding.
9. Electrolytic Action on Cable Sheaths, etc.
10. Constants of Conductors used for Telegraph and Telephone Purposes.

GROUP I.

1. Submarine Cables.

GROUP K.

1. Electric Lighting.
2. Lifts.
3. Heating Systems.
4. Pneumatic Tube Systems.
5. Gas and Petrol Engines.