



WS No. 19 Mark III

**This file has been down loaded from
The Wireless-Set-No19 WEB site.**

**All files from this WEB site are free of charge.
If you have been charged for this file then please
contact the person you obtained it from as he/she
has illegally obtained both the file and money they have
charged you.....**

P.W.—D. 13.

**POST OFFICE
ENGINEERING DEPARTMENT**

**TECHNICAL PAMPHLETS
FOR
WORKMEN**

Subject :
Trunk Telephone Exchanges

ENGINEER-IN-CHIEF'S OFFICE

1919

===== LIST OF =====

Technical Pamphlets for Workmen.

=====

GROUP A.

1. Magnetism and Electricity.
2. Primary Batteries.
3. Technical Terms.
4. Test Boards.
5. Protective Fittings.
6. Measuring and Testing Instruments.
7. Sensitivity of Apparatus.

GROUP B.

1. Elementary Principles of Telegraphy and Systems up to Morse Duplex.
2. Telegraph Concentrators.
3. Wheatstone. Morse Keyboard Perforators.
4. Quadruplex. Telegraph Repeaters, Sx., Dx., and Quad.
5. Hughes Type-printing Telegraph.
6. Baudot Multiplex.
7. Western Electric Multiplex. Murray Multiplex. Other Systems.
8. Fire Alarm Systems.

GROUP C.

1. General Principles of Wireless Transmission and Reception.

GROUP D.

1. Elementary Principles of Telephony.
2. Telephone Transmission. "Loading." Telephone Repeaters and Thermionic Valves.
3. Principles of Telephone Exchange Signalling
4. Magneto Exchanges—Non-Multiple Type.
5. Magneto Exchanges—Multiple Type.
6. C.B.S. Exchanges—Non-Multiple Type.
7. C.B.S. Exchanges—Multiple Type.
8. C.B. Exchanges—No. 9 Type.
9. C.B. Exchanges—No. 10 Type.
10. C.B. Exchanges—No. 12 Type.
11. C.B. Exchanges—22 Volts.
12. C.B. Exchanges—40 Volts.
13. Trunk Telephone Exchanges.
14. Telephone Exchange Maintenance.
15. Telephone Testing Equipment.
16. Routine Testing for Telephone Exchanges.
17. Internal Cabling and Wiring.
18. Distribution Cases, M.D.F. and I.D.F.
19. Cord Repairs.
20. Superposed Circuits, Transformers, etc.
21. Call Offices.

[Continued on page iii. of Cover.]

TRUNK TELEPHONE EXCHANGES.

(D.13.)

The following pamphlets in this series are of kindred interest :

- D.1. Elementary Principles of Telephony.
- D.2. Telephone Transmission. "Loading." Telephone Repeaters and Thermionic Valves.
- D.3. Principles of Telephone Exchange Signalling.
- D.14. Telephone Exchange Maintenance.
- D.15. Telephone Testing Equipment.
- D.16. Routine Testing for Telephone Exchanges.
- D.17. Internal Cabling and Wiring.
- D.18. Distribution Cases, M.D.F. and I.D.F.
- D.19. Cord Repairs.
- D.20. Superposed Circuits, Transformers, etc.
- D.21. Call Offices.
- F.8. Wiring of Subscribers' Premises.
- G.1. Secondary Cells, Maintenance of.
- G.2. Power Plant for Telegraph and Telephone Purposes.
- G.3. Maintenance of Power Plant for Telegraph and Telephone Purposes.

TABLE OF CONTENTS.

| | PAGE |
|--|------|
| LAMP SIGNALLING SWITCH SECTION | 3 |
| TRUNK LINE CIRCUITS | 5 |
| METHOD OF TRANSFERRING TRUNK CIRCUIT FROM "ORDINARY" TO "CONCENTRATION" POSITION | 6 |
| TIME CHECKS | 7 |
| TRUNK CORD CIRCUIT | 8 |
| A CALL TRACED THROUGH C.B. EXCHANGE | 11 |
| RINGING JUNCTIONS | 18 |
| TRANSFER CIRCUITS | 20 |
| NIGHT ALARM CIRCUIT | 22 |
| GENERAL ARRANGEMENTS OF WIRING | 22 |
| MAINTENANCE | 23 |

TRUNK TELEPHONE EXCHANGES. LAMP SIGNALLING.

In 1896 the Department acquired the Trunk lines in the United Kingdom and introduced a system of working commonly known as the "Permanent Current," or "P.C." system, which provided automatic calling and clearing by the insertion or withdrawal of the plug at either end of the line. This system was in general use until 1904, when the present Lamp Signalling Trunk Exchange system, which forms the subject of this pamphlet, was introduced. The latter system retains only the automatic clearing features of the earlier "P.C." system.

The general principle of Trunk working is that all long distance connections are made over two classes of circuits only:—

- (1) Trunk Circuits connecting the Main Exchanges in the country.
- (2) Junction Circuits connecting the Main Trunk Exchanges with the Local Exchanges in the same city, and other small towns in the neighbourhood.

LAMP SIGNALLING SWITCH SECTION.

The Lamp Signalling Switch Section (Fig. 1) is 4 feet 6 inches wide, and provides accommodation for two operators. The frames are of iron, faced with mahogany, and the upper portion of the Switch Section is divided into three panels.

The side panels contain the Trunk Line Circuits, each provided with Line Calling Lamp, Time Check Key, and Concentration Signalling Jacks, the incoming end of two Transfer Circuits multiplied at the outgoing end round all the Switch Sections, and local transfers if necessary.

The centre panel contains a multiple of transfer circuits sufficient to provide two circuits to every operator's position in the Exchange, and a multiple of outgoing Junctions to the various Local Exchanges in the city.

The Plug Shelf is horizontal, and continuous over the whole length of the Section, and is drilled for fourteen pairs of Plugs and Cords, seven pairs per position, and 44 Signalling Lamps. "Concentration" Sections only are fully equipped. The "Ordinary" Sections are fitted with twelve pairs of Plugs and Cords, six pairs per position, and 38 Signalling Lamps. **The Keyboard** is also horizontal and in line with the Plug Shelf, and provides accommodation for the combined Speaking and Ringing Keys, Order Wire Keys, Coupling Keys, Transfer Keys, and Order Wire Ringing Keys, leaving 7 inches by 1 foot 9 inches clear writing space for each operator. Provision is also made for fitting one Calculagraph in the centre of the Keyboard for the use of two operators for the purpose of stamping the time and duration of call on the tickets.

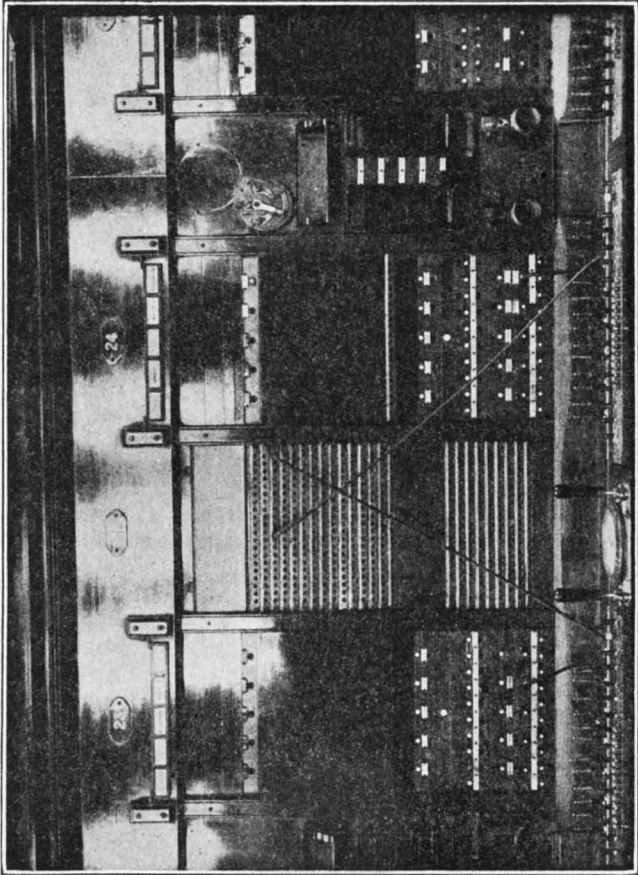

FIG 1.—CONCENTRATED SECTION. FRONT VIEW OF UPPER PORTION.

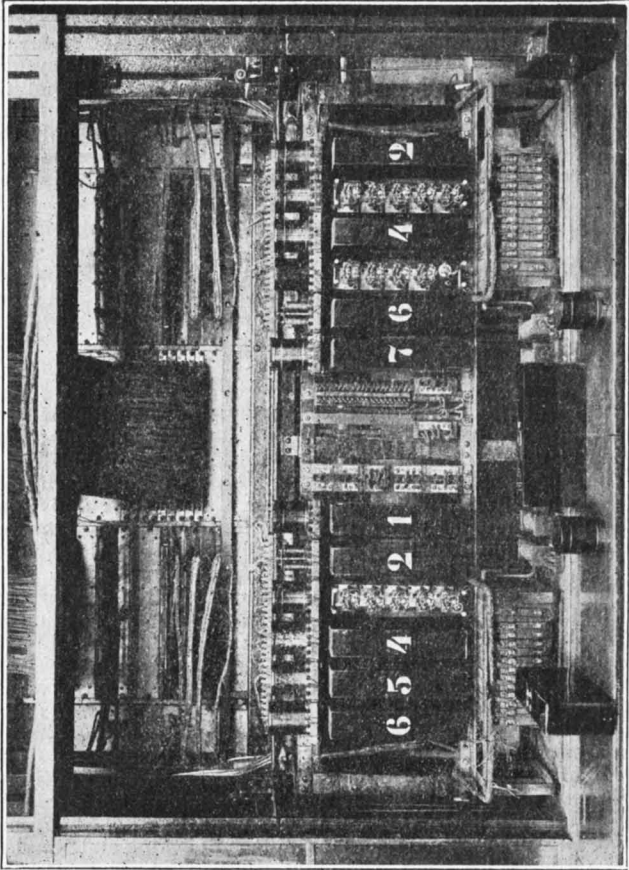

FIG. 2.—ORDINARY SECTION, BACK VIEW OF LOWER PORTION.

The operators' positions in the "Ordinary" or "Day" group of Switch Sections are equipped with 6 pairs of Plugs and Cords, three Clearing Lamps, and two Combined Ringing and Speaking Keys associated with each pair of cords, Generator Ringing Pilot Lamp, 1 Order Wire Ringing Key, 1 Coupling Key, 1 Transfer Speaking Key, and Order Wire Keys to the various Local Exchanges to which Order Wire Junctions are worked. The Sections are open at either end, and when placed "end on" form an unbroken line. Inside the Sections are two shelves for the Junction and Transfer Multiples, and accommodation for the Cord Circuit Apparatus. A troughing for the Cables forms the lower back portion of the Sections. The back is closed with sliding iron panels, and is practically fireproof. Fig. 2 shows the lower portion of a Section as seen from the back with sliding iron panels removed.

Trunk Circuit Terminations. The positions are divided into two groups for busy and slack periods of working, and are designated "Ordinary" and "Concentration" positions respectively. Four or five circuits are normally worked from each position in both groups during the busy period, and 12 or 15 circuits from each "concentrated" position during the slack period. Each trunk circuit worked from the "Ordinary" group of positions can be wired to a duplicate set of connections on one of the positions in the "Concentration" group. In cases where a large number of lines connect town to town to meet the day traffic, only sufficient lines to carry the night traffic are wired to a concentrated position.

Concentration Signalling Jacks are fitted on each operator's position, as previously stated, to enable the operators to transfer the working from one group to another to suit the Traffic requirements.

TRUNK LINE CIRCUITS.

Normally, two 12V. batteries, earthed at the central point, are connected through 200 ω + 200 ω bridging coils to the trunk line at each end of the circuit, the *positive* being connected to A and *negative* to B. A Line Calling Relay, R7, Fig. 3, has a condenser joined in series in order to permit of the relay being actuated by generator currents, but not by current from the 24V. battery, which is also joined across the line. When a generator is applied to line, Relay R7. is actuated. The current from the earthed 24V. battery flows *via* the Pilot Relay, auxiliary springs of S3, Relay R5, armature and bottom contact of Relay R7, to earth. Relay R5 is actuated, and, owing to the retaining connection, remains so. The lamp circuit L1 is completed *via* the Pilot Relay, contacts of S1, left-hand armature and bottom contact of Relay R5, to earth; Lamp L1 glows.

On the insertion of a Plug in S_3 the circuit of Relay R_5 is broken at the contacts of the auxiliary springs of S_3 , its armature is released, and the Lamp L_1 darkens. The retaining Relay R_5 is joined in parallel with the line lamp, so that, in the event of a fault arising in the latter at night, when a call is received, a current will flow through the retaining relay in series with the Pilot Relay, thus closing the circuit of the Pilot Lamp and actuating the night bell if the latter is switched on.

At certain of the smaller sized Exchanges Indicator jacks are used in place of the Line and Retaining Relays, and the lamp circuit is made through the local contacts of the jack Indicator. Duplicate Indicator jacks are provided for concentration purposes, and when the time arrives for concentration, the operator at the "ordinary" position informs the operator at the "concentration" position over the Transfer Circuit that the circuit is about to be changed over, and immediately removes the insulating plugs from the relevant jacks, and places them in the Indicator jacks, thus disconnecting the Permanent Current Battery.

METHOD OF TRANSFERRING TRUNK CIRCUIT FROM "ORDINARY" TO "CONCENTRATION" POSITION.

Reference should again be made to Fig. 3. S_3 represents the "ordinary" and S_4 the "duplicate" line connections, and S_1 and S_2 the corresponding concentration signalling jacks. During the busy period an ivory insulating plug is inserted into S_1 to complete the circuit of the Calling Lamp L_1 , and a second plug is inserted into S_4 to disconnect the line circuit from the signalling apparatus at the latter point. When it is necessary to concentrate the circuits, the operator at the "Ordinary" position, if the circuit is disengaged, withdraws the plug from S_1 and inserts it in S_3 . The withdrawal of the plug closes the circuit of the signalling lamps, L_1 and L_2 , causing both lamps to glow, the battery circuit connections being as follows:— Considering first the Concentration position; the current from the earthed battery flows *via* the Pilot Relay, Lamp L_2 , auxiliary springs, teed connections to the inner spring and long spring of S_2 , signalling line, long spring and inner spring of S_1 to earth.

At the "Ordinary" position, the current flows from the earthed battery *via* the Pilot Relay, Lamp L_1 , auxiliary springs of S_1 , signalling line, third auxiliary spring, inner and long spring of S_2 , signalling line, long and inner spring of S_1 to earth.

On seeing the signal, the operator at the "Concentration" position takes the insulating plug from S_4 and places it in

S₂, thus breaking the signalling circuit on the auxiliary contacts of S₂. Both lamps darken, and the line signalling apparatus is joined in circuit.

The arrangement ensures the concentration of the circuits without confusion or noise, and without the services of an officer on the Trunk Test Board. It also prevents the interruption of any conversation which may happen to be in progress at the time authorised for changing the working positions.

TIME CHECKS.

To assist the operators to control the duration of a call, three minute "Time Checks" are provided at the Lamp Signalling Exchanges. These Time Checks consist of an Electro-magnet associated with a toothed wheel 3 inches in diameter, and a loose contact arm mounted on a spindle. This spindle is revolved by an electrically operated driving gear which consists of an Electro-magnet, ratchet and pawl arrangement, and toothed wheel gearing. When the Time Check Key (Fig. 3) is pressed, the plug being inserted in jack S₃, current from the positive side of the 24V. battery flows *via* the Time Check Key, auxiliary contacts of S₃, through the coils of the Time Check Electro-magnet, top left-hand contact and armature of Relay R₅, auxiliary contacts of S₁, Lamp L₁, and Pilot Relay, to the negative side of the battery; the armature of the Time Check is attracted and the contact arm CA is lifted so as to permit of a projecting pin engaging with the revolving toothed wheel W. At the end of three minutes CA comes in contact with a hinged platform C, which is held in position by a weak spring, and closes the battery circuit of the Lamp L₁. Thus the operator's attention is called to the fact that three minutes have elapsed, by the glowing of the lamp. The path of the current causing the lamp to glow is *via* the Pilot Relay, Lamp L₁, auxiliary springs of S₁, contacts C, CA to earth. The wheel continues to revolve, and after about 20 seconds the contact arm slides off the hinged platform, and by the action of gravity falls back to its normal position of rest.

A mechanical device fitted to the electro-magnet permits of the contact arm being reset to zero by pressing the Time Check Key before the expiration of three minutes if desired. If, when the Lamp L₁ is glowing, the plug is withdrawn from S₃, a current from the negative side of the 24V. battery will flow *via* the Pilot Relay, auxiliary springs of S₃, Time Check Electro-magnet Coils, top left-hand contact and armature of Relay R₅, contacts C, and CA to earth. The electro-magnet is energised and automatically resets CA. If the plug is withdrawn before the expiration of three minutes, the instrument will be reset automatically as soon as CA comes in contact with C, the flow of current operating the electro-magnet as

P. O. TRUNK EXCHANGE SYSTEM.

Explanatory Diagram of Trunk Circuit with Time Check.

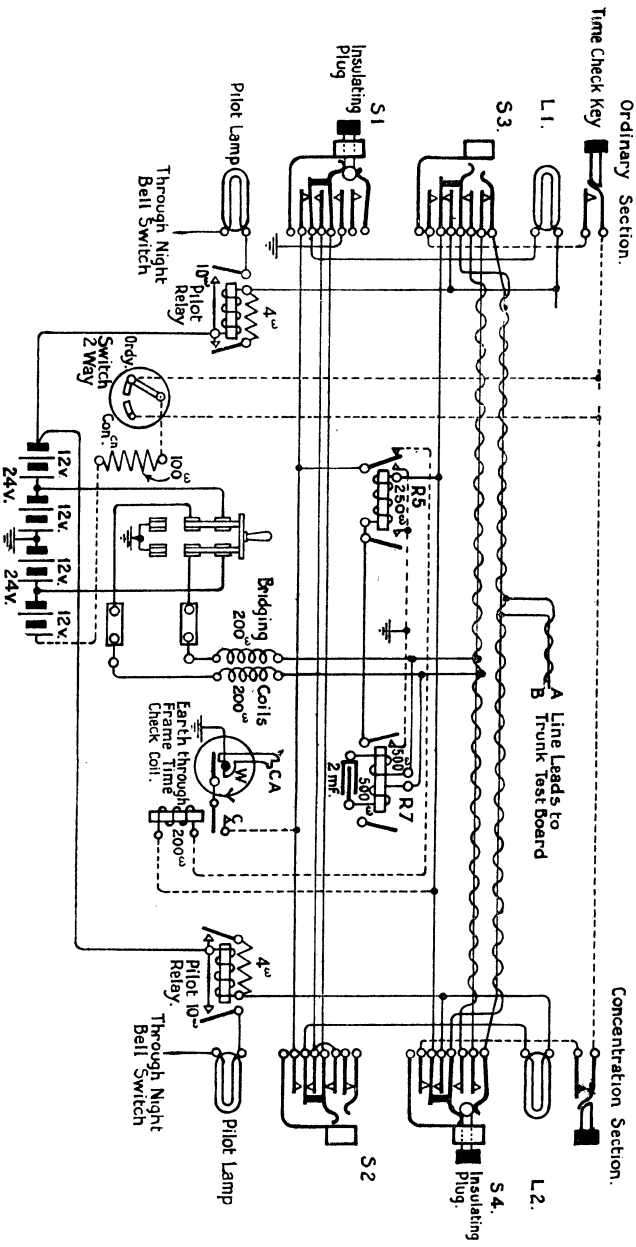

Fig. 3.

POST OFFICE TRUNK EXCHANGE SYSTEM

Explanatory Diagram of Cord Circuit Connections.

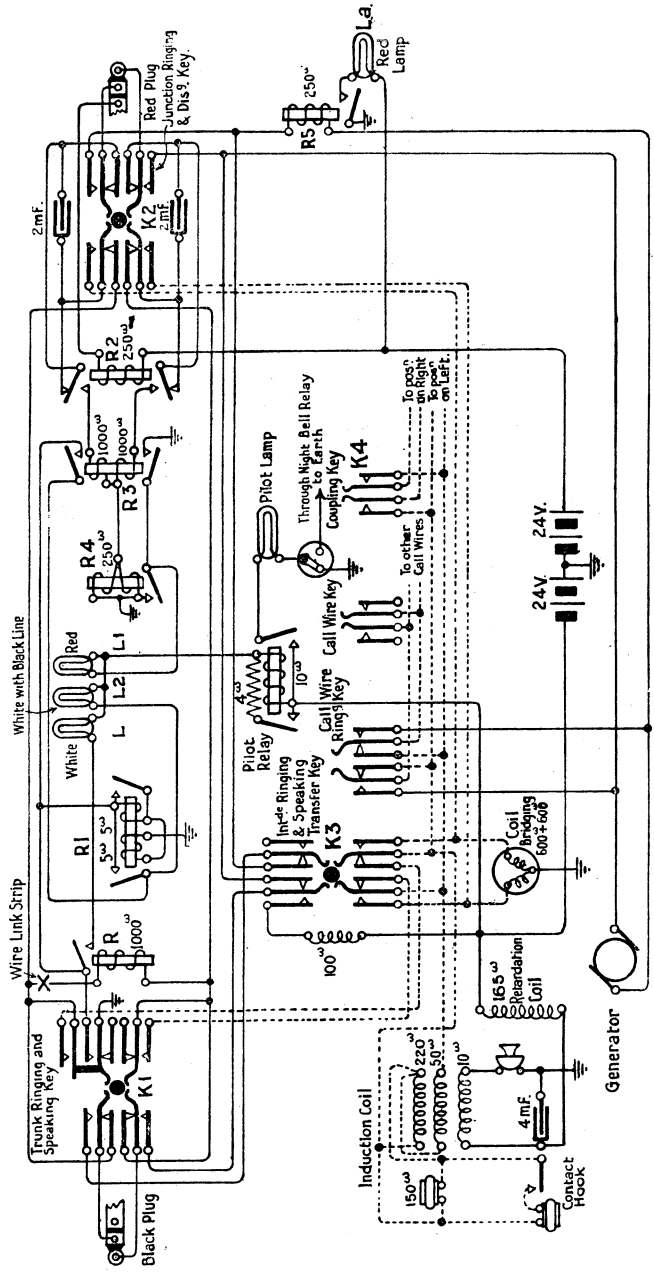

Fig. 5.

described in the preceding paragraph. At certain Trunk Exchanges the action of the Time Check is independent of the manipulation of the plug. In such cases the Time Check can be restored by operating the key a second time. Fig. 4 shows

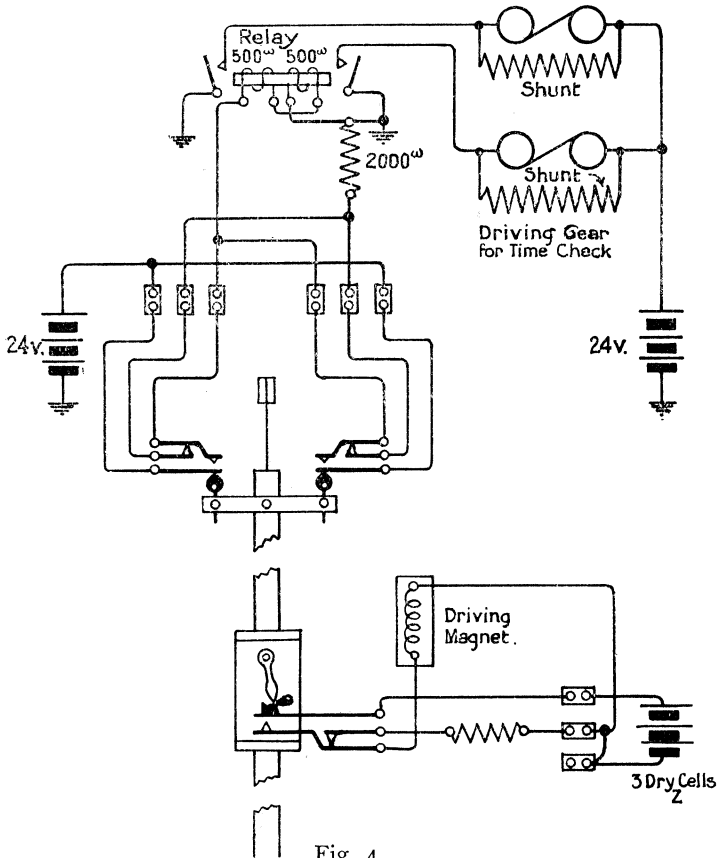

Fig. 4.
**PENDULUM ELECTRICAL SECONDS (Bowel),
FOR DRIVING TIME CHECKS.**

the arrangement for the electrical clock used for timing the Time Check driving gear.

TRUNK CORD CIRCUIT.

The Cord Circuit should now be considered (Fig. 5). When one trunk circuit is joined through to another trunk circuit,

the connections from plug to plug are direct, and the 1,000 ohm Relay R. is the only bridge across the line, but when a trunk circuit is extended to a junction circuit, two 2 m.f. condensers are joined in series in the circuit to prevent false clears, and Relay R₃ is bridged across the line on the junction side of the condensers with the centre point of the coils to earth through Relay R₄. Relay R₂, which brings the condensers into circuit, is actuated when the Red Plug is inserted in a junction circuit jack, the sleeve of which is earthed through 250 ohms. When the Trunk Clearing Relay R is actuated by the current from the distant exchange, a current flows *viâ* the Pilot Relay, Lamp L, contact and armature of Relay R, coils of Retaining Relay R₁ in series, to earth; Lamp L glows, Relay R₁ is actuated and current flows *viâ* Pilot Relay, Lamp L₂, left-hand armature and bottom contacts and coils of Relay R₁ to earth. Relay R₁ remains actuated and Lamp L₂ glows, and continues to do so until Relay R₁ is short-circuited by turning Key K₁ to the speaking position.

A generator call, therefore, given immediately after the completion of a conversation will actuate Relay R momentarily, and will cause Lamp L₂ to glow until the operator goes into circuit by turning the Key K₁. Also if the permanent current is applied to the distant end of the line by the withdrawal of the plug, Relay R will be actuated and the Lamps L and L₂ will glow until the signal receives attention.

When Relay R₁ is actuated, the right-hand armature connection short-circuits one of the coils, thus reducing the circuit resistance.

The coils of Relay R₃ are differential to currents from an earthed battery sent in parallel over the wires of a junction circuit, but are actuated by transient signals round the loop. The clearing battery signals, however, received over the junction wires from Local Exchanges worked on Automatic signalling principles, will actuate Relay R₄ after passing through Relay R₃ and the Lamp L₁ will glow. The current from the negative side of the battery passes through the Pilot Relay, Lamp L₁, armature and contact of Relay R₄ to earth.

Relay R₃ is used for the receipt of transient ring-off signals from Magneto subscribers, and on the receipt of these signals its armature is attracted, and Relay R₁, Lamps L₂ and L₁, are brought into operation.

Again tracing the current from the negative side of the battery it passes through the Pilot Relay, Lamp L₁, left-hand armature and bottom contact of Relay R₃ to earth; also *viâ* Lamp L₂, right-hand armature and bottom contact of Relay R₃ and both coils of Relay R₁ to earth. Relay R₁ is actuated

and remains so until the Key K₁ is thrown and the coils of Relay R₁ are short-circuited.

Use of Keys. Two combined Speaking and Ringing Keys are associated with each pair of plugs and cords. When the levers of keys K₁ and K₂ are drawn forward, Generator ringing currents are applied direct on the Trunk and Junction side of the circuit respectively, and when the levers are pressed in the opposite direction Key K₁ bridges the operator's speaking set across the circuit and Key K₂ disconnects the junction side of the circuit. A third Key, K₃, common to all the cords on the position, is used for transferring the operator's speaking set from the contacts of Key K₁ to Key K₂.

When the Black Plug is in the Trunk circuit jack, and the Red Plug in a Junction circuit jack, Keys K₂ and K₃ in the normal, and the lever Key K₁ thrown into the speaking position, the operator is able to speak or listen on both sides of the circuit, the set being joined up through the lower inner and long springs of Key K₂, and the outside short and long springs of Key K₁.

On Key K₂ being pressed back the condenser side of the red cord circuit is disconnected at the left-hand inner springs of that key, and the operator can speak on the Trunk side only.

If now Key K₃ is pressed back, the lower inner springs are disconnected and the operator's set, which is permanently connected to the long springs, is joined up to the junction side of the cord circuit. A division of the circuit is thus effected without the necessity of moving the plugs from the jack.

When Key K₂ is in the disconnecting position the Bridging Coil $600\omega + 600\omega$ is joined across the junction side of the circuit, permitting the engaged test to be applied to multiple circuits. To test, keys K₂ and K₃ are pressed back and the socket of the multiple is touched with the tip of the Red Plug. If the circuit is engaged a battery current is connected to the socket *via* the sleeve of a Red plug inserted in some other part of the multiple, and a click will be heard in the operator's receiver, due to a leak current from socket passing to earth through Bridging Coil and Induction Coil

When Generator ringing currents are sent over either the Trunk or Junction circuits by the movements of keys K₁ or K₂, the Generator Relay R₅ is actuated, and a Red Lamp La glows, indicating to the operator that the ringing currents are going out to line.

The key K₃ serves a dual purpose. Besides transferring the operator's speaking set from the contacts of Key K₁ to Key K₂, if placed in ringing positions, it joins up a battery to Key K₁ in place of Generator, for ringing on intermediate Trunk Circuits. A 24V. battery is joined up to the "A" line and the

“B” line is disconnected when Key K₁ is turned to the ringing position. The Coupling Key K₄ is supplied for coupling together the cord circuits of adjacent positions to enable the operator to use the cords on each side without removing the connector of the speaking set. The Call Wire Keys are provided for Down Call Wires to Exchanges having more than five junction lines, and a Call Wire Ringing Key common to the position is also supplied for signalling when continuous attention is not given.

Operator's Speaking Set. The primary circuit of the operator's speaking set is joined up in the usual way for Common Battery working. The secondary circuit is arranged so that when an operator is speaking, only a portion of the induced currents passes through the operator's receiver, the major portion being transmitted to the line circuit. This result is obtained by joining the 50 ohm, and 220 ohm coils of the induction coil in series in the line circuit, whilst the receiver forms a shunt across the 220 ohm coil when the apparatus is connected to the line. The arrangement has the advantage of cutting down side tone and the switch room noises are not produced in the receiver, thus enabling faint speech to be heard more readily.

A CALL TRACED THROUGH C.B. EXCHANGE.

Booking the Call. A subscriber desiring a *Trunk Call* which will be routed *via* a Main Trunk Exchange has to book the call first. This is done by connecting him to a special junction called a “**Record Circuit**” from Local Exchange to Trunk Exchange. This record circuit terminates on a special position called a “**Record Transfer Position**,” whence it can be extended to one of a group of operators at a special table called “**Record Table**,” who notes the call on a ticket and passes it to the Trunk operator to put through in turn. A subscriber to a Liverpool Common Battery Exchange, say Bank 4430, desires to pass a call to a Bristol subscriber. The lamp associated with the subscriber's circuit at the C.B. Exchange glows on the subscriber lifting the receiver from the rest; the Local Exchange Operator takes the answering plug of a pair of plugs and cords and inserts it in the answering jack. The cut-off Relay is actuated, the Line Relay is disconnected, and the Cord Circuit Battery and Clearing Relay are brought in circuit. The operator throws the speaking key, coming in circuit, and, if a trunk service is required, immediately tests in the multiple for a disengaged Record Circuit, and, if a circuit is free, inserts the plug to complete the connection.

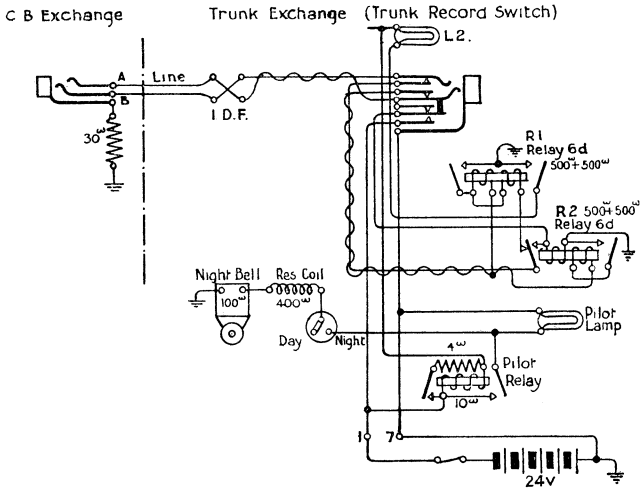

Connections of Record Operator's Explanatory Diagram.

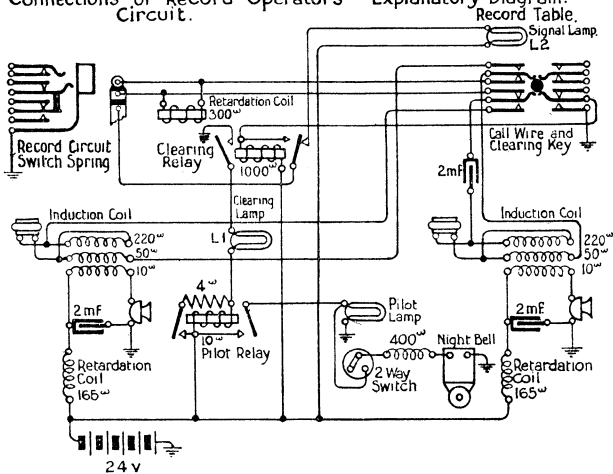

Fig. 6.

P.O. TRUNK EXCHANGE SYSTEM.

RECORD-CIRCUITS TO COMMON BATTERY EXCHANGES.

Record Circuit.—Fig. 6 should now be consulted to trace the path of the current from the Local Exchange. When the operator inserts the plug in the record circuit jack at the C.B. Exchange, current flows through the ring of the plug to the “B” line, and inner contact of the 8-point jack at the Trunk Exchange, left-hand armature and top contact of Relay R₂, Coils of Relay R₁ in series, inner contact of the 8-point jack, to the “A” line, and through the tip of the C.B. plug to earth through the cord circuit supervisory relay at the Common Battery Exchange.

The Relay R₁ is energised, and closes the circuit of the line calling lamp, the current flowing *viâ* the Pilot Relay, the Line Lamp L₂, the right-hand armature of Relay R₁ to earth. After the armature of Relay R₁ is attracted, the current flowing from the “B” line through the right-hand coil winding, passes direct to earth *viâ* the local contact or relay instead of returning to the C.B. Exchange along the “A” line.

The flow of the current through the supervisory Relay connected in the circuit of the “A” line at the C.B. Exchange is, therefore, diverted and the corresponding clearing lamp remains glowing until the Record Transfer operator at the Trunk Exchange inserts the plug into the line jack. The insertion of the plug at the Trunk Exchange completes the circuit of Relay R₂, the current flowing *viâ* power tag No. 1, the auxiliary contacts of the 8-point jack, one coil of Relay R₂ to earth. Relay R₂ is now energised, and breaks the circuit of Relay R₁. The armature of Relay R₁ is released and the Calling Lamp darkens.

The insertion of the Trunk record plug in the Record Circuit jack, in addition to placing the Record Table operator in direct communication with the subscriber and bridging the 300 ω Retardation Coil across the line, closes the circuit of the Signal Lamp L₂ on the Record Table, *viâ* the 24V. earthed battery, Lamp L₂, the top contact, armature of the clearing relay, and the sleeve of the plug and socket of the 8-point jack to earth. [Note:—It is not necessary for the Record Transfer operator to speak on the circuit.] The Record Table operator enters the particulars of the call on a ticket and momentarily throws over the clearing key; the circuit of the clearing relay is made *viâ* the

24V. earthed battery, relay coils in series, outer connections of clearing key, to earth; the 1,000 ω relay is actuated, and the clearing and Pilot Lamps glow and remain glowing, owing to the retaining connection on the clearing relay, until the plug is withdrawn from the Record Circuit jack. After the call is recorded, and on the withdrawal of the plug at the Trunk Exchange, the current from the Common Battery Exchange flows to the "B" line, thence to armature of Relay R₂ and contact, left-hand coil and to earth, causing the Common Battery Exchange cord circuit clearing lamp to glow,

The inner contacts of the 8-point jack must make contact before the auxiliary contacts are broken when a plug is being withdrawn.

The retaining effect of the Relay R₂ prevents false calls being received.

On the withdrawal of the plug at the Common Battery Exchange, current through Relay R₂ ceases, its armature is released, and the circuit is free for the receipt of further calls.

The Call Matures.—The ticket on which the call is recorded is circulated to the particular section on which the Bristol Trunk circuits are terminated, and placed on a ticket rack in view of the operator who is dealing with the Bristol calls. To establish the call the operator inserts the Black Plug (Fig. 5) in a disengaged trunk circuit, Lamps L and L₂ glow, due to the permanent current from the Bristol Trunk Exchange, the lever of Key K₁ is placed in the ringing position, and generator signals are sent to line. The Line Relay at Bristol is actuated, and the line lamp glows and remains glowing until the Bristol operator inserts a Black Plug in the line jack. On this being done, Lamp L at the Liverpool Trunk Exchange darkens, and Lamp L₂ also darkens as soon as the Liverpool operator turns the Key K₁ to the speaking position. The Bristol operator also turns Key K₁ to the speaking position, the particulars of the call are passed forward, and the attention of the Bristol subscriber gained for Liverpool.

C.B. Junction Circuit.—The Liverpool operator now presses a "Bank" Order Wire Key, and says 4430. The Bank operator

allots a free junction, saying "Ten" (*i.e.*, allocating Junction No. 10), and, if the subscriber's circuit is disengaged, completes the connection and depresses the ringing key. The Trunk operator inserts the Red Plug of the pair of cords selected into the jack of No. 10 Bank Junction. The cord circuit Relay R4 (Fig. 7) is actuated by the current received over the loop in parallel, *via* the 27ω coil of relay from the Common Battery Exchange and Lamp L1 glows. On the subscriber lifting the receiver to reply, the battery supply to the 27ω coil of relay is

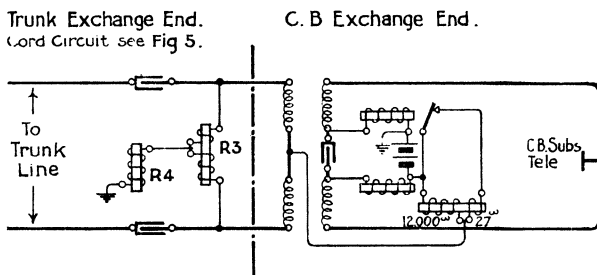

Fig. 7.

C.B. SUBSCRIBER CONNECTED TO TRUNK LINE.

SKELETON DIAGRAM SHOWING SIGNALLING RELAYS ONLY.

disconnected and current is sent *via* the $12,000\omega$ coil. The reduced current is not sufficient to retain relay R4, and the supervisory lamp L1 (Fig. 5) at the Trunk Exchange darkens. On the subscriber restoring the receiver to the rest on the completion of the call, the battery is again sent *via* the 27ω coil to the Trunk Exchange actuating R4 and causing lamp L1 to glow. On the withdrawal of the plug at the Trunk Exchange, a clear is given to the Local Exchange operator, who restores to normal.

Record Circuit, Magneto Exchanges.—In view of the fact that Magneto Exchanges still form a large part of the Local Exchange installations in the country, it is necessary to describe the circuit connections for passing a call to the Trunk Exchange from a Magneto Exchange.

P. O. TRUNK EXCHANGE SYSTEM.

Record Circuits to Magneto Exchanges.

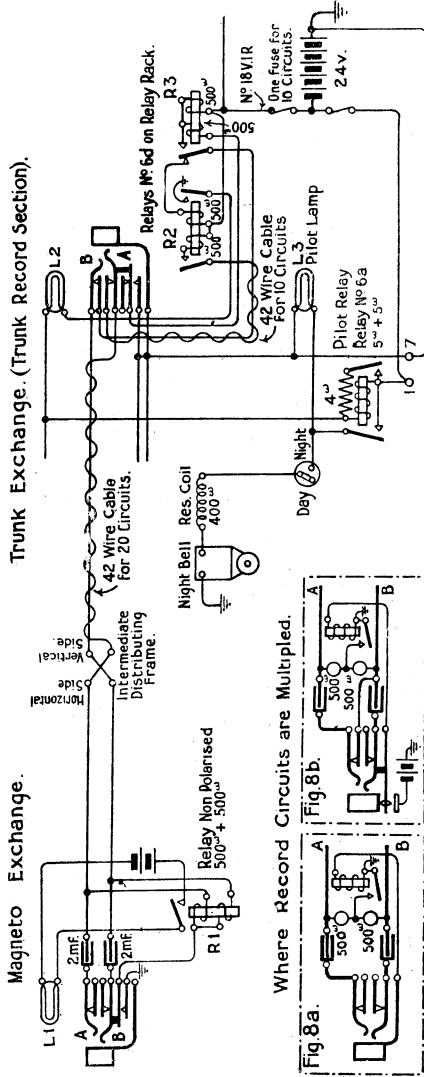

Fig. 8.

The connections at one of the Magneto Exchanges, as well as on the Trunk Exchange (Record Switch Section), are shown in Fig. 8. Where the Record Circuits are multiplied at the Magneto Exchange, however, the case is different, and the circuit conditions are as shown in Figs. 8a and 8b.

A differential relay R₁ is permanently connected to the two wires of the Record Circuit at the Magneto Exchange, and an earthed battery is joined in the circuit through a second relay R₂ at the Trunk Exchange. When a subscriber is joined through to the circuit at the Magneto Exchange, the centre of Relay R₁ is earthed and a current from the Trunk Exchange passes through the right-hand coil of R₂. The armature of R₂ is attracted and immediately afterwards the current passes through both coils of Relay R₂ in multiple, and through Relay R₁ differentially. The lamp L₂ glows but the Relay R₁ is not affected. On taking a call, the Trunk Exchange operator inserts a plug into the line jack, and the current through Relay R₂ ceases. Lamp L₂ darkens and Relay R₃ is actuated in readiness to send the clearing signal. On the withdrawal of the plug at the Trunk Exchange the inner contacts of the jack *make* before the auxiliary contact *breaks* and a current flows through Relay R₃, the "B" line, and through one coil of Relay R₁ which is actuated and lamp L₁ glows. Immediately the plug is withdrawn at the Magneto Exchange, Relays R₁ and R₃ return to the normal positions and Lamp L₁ darkens.

In the case of Figs. 8a and 8b the operations are slightly different. On the subscriber desiring a Trunk connection, the operator at the Local Magneto Exchange tests for a disengaged circuit in the multiple in the ordinary way, and, if free, completes the connection. The relay in connection with the socket is actuated, and the centre point of the bridging coils earthed. The current from the Trunk Exchange Battery passes through the right-hand coil of Relay R₂, the armature and top contact of Relay R₃, the inner contact of the 8-point jack, "B" line, and one coil of the bridging coils to earth. Relay R₂ is actuated. The current then passes through both coils of Relay R₂ in multiple, in parallel over the Record lines, and through both coils of the bridging coil to earth at the Magneto Exchange. Lamp L₂ glows, the battery circuit being completed through the Pilot Relay, Lamp L₂, right-hand armature and contact of Relay R₂ to earth. On the Trunk Exchange operator inserting a plug into the line jack, the current through Relay R₂ ceases, Lamp L₂ darkens, and Relay R₃ is actuated in readiness to send a clearing signal. The arrangement at many of the Local Exchanges does not permit of the clearing current being received from the Trunk Exchange, and in those cases the subscriber's ring off signal is depended upon. A ticket is made out by the Record Table operator, and dealt with in the same manner as a call from a Common Battery Exchange. The junction circuit

over which the call is established is shown in Fig. 9. The Trunk operator passes the particulars of the originating subscriber over the Order Wire, and the Local Exchange operator allots the junction. The Trunk operator inserts the Red plug into the jack of the junction circuit allotted; Relay R is actuated by the current from the sleeve of the Red Plug passing through its coils to earth. The current is cut off from the lines and the earthed arrangement of relays in the Trunk Cord Circuit substituted. The current from the Local Exchange flows *via* the Indicator, Bridging Coils and (or Relay, if Relay and Lamp

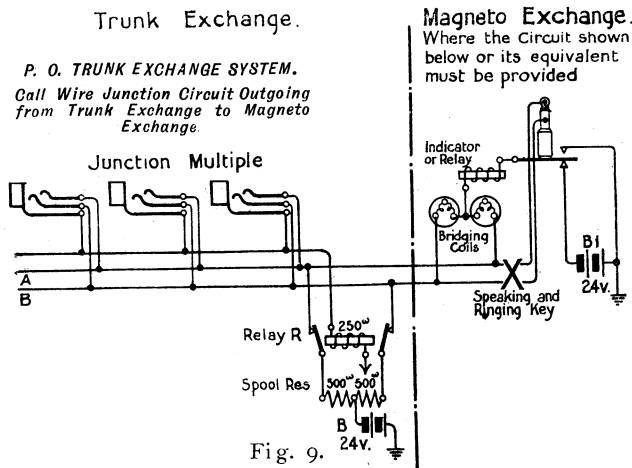

Indicator is fitted) over the junction lines in parallel, through Relays R₃ and R₄ (Fig. 5) at the Trunk Exchange to earth. A supervisory signal is displayed at both Exchanges. On the operator at the Magneto Exchange lifting the plug to make the desired connection, an earth is substituted for the battery, and the supervisory signals at both exchanges cease.

On the conclusion of the conversation the subscriber's ring off signals operate Relay R₃ (Fig. 5), Lamp L₁ glows momentarily and Lamp L₂ glows until Key K₁ is turned to the speaking position. The plug is withdrawn at the Trunk Exchange, Relay R (Fig. 9) assumes the normal, and an earthed battery current flows *via* the lines, bridging coils, and Indicator to earth at the Magneto Exchange. A clearing signal is displayed and the Magneto Exchange operator clears.

RINGING JUNCTIONS.

Fig. 10 shows the arrangement adopted where call wires are not in use. When the Red Plug (Fig. 10b) is inserted in

POST OFFICE TRUNK EXCHANGE SYSTEM.
Connections of Test Multiplied Junction Circuits for Magneto Exchanges

Fig 10.

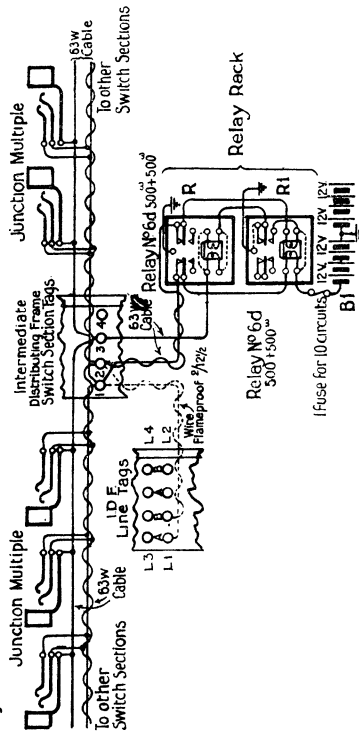
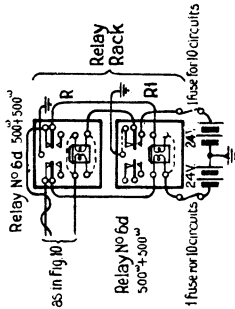

Fig 10a.

Arrangement at Exchanges where the sleeve connection of the Red Plug is served by a -24v Battery.



Trunk Cord Circuit Explanatory Diagram Fig 10b.

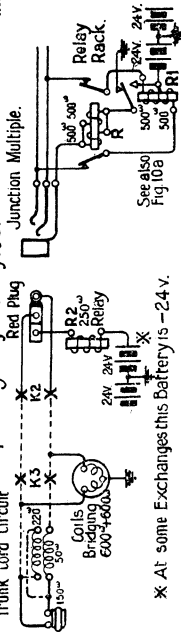

Fig. 10.

Note:- When the Red Plugs inserted in the Multiple R&R2 are actuated opposing current is cut off Lines and current put on Socket throughout Multiple to test, put over K2 & K3 to speaking position and touch socket of Multiple with tip of plug engaged click will be heard in the operators receiver due to a leak current from socket passing to earth through Bridging and Induction Coils.

If circuit is clear in Multiple but not cleared at Magneto Exchange R1 will be energised and current again put on socket. If in this condition test is made, a vibratory movement will be set up in R, R1 and also in Operators Receiver. At London and Cardiff -24v is used on sleeve, therefore +24v will be used on bottom stop of Relay R1.

the multiple jack, Relays R and R₂ are actuated; opposing current is cut off lines, and current is put on socket throughout the multiple. To test, put over Keys K₂ and K₃ to speaking position, and touch socket of multiple with tip of Red Plug; if engaged, click will be heard in operator's receiver due to a leak current from socket passing through Bridging Coils and Induction Coils.

TRANSFER CIRCUITS.

Direct Transfer Circuits. For through trunking, transfer circuits are necessary, and the arrangements shown in Fig. 11 provide direct communication between every operator's position in the Switch Room without the intervention of a Transfer operator. When a circuit is in use, a battery is joined up to the socket throughout the multiple, and the test for a disengaged transfer circuit is made in the same way as for a Test on a Multiple Junction Circuit. For example, if the operator at the Birmingham position in Liverpool requires to pass a call to Blackburn which terminates on position, say No. 17, the operator tests No. 17 transfer circuit in the multiple, and if clear completes the connection. The current flows from the 24 V. battery through Relay R₂ without actuating it, through the socket on the 3-point jack, and the high resistance Relay R to earth. Relay R is actuated, and the lamp on the trunk panel at No. 17 position glows, and as the operator's telephone is joined to the inner springs of the 8-point jack, direct speaking connection is established. In certain Trunk Exchanges this arrangement has been modified and the called operator establishes speaking connection by means of a cord circuit. The lamp circuit is made *via* the lamp, outer auxiliary spring of the 8-point jack, lower contact and armature of Relay R, and auxiliary springs of the 8-point jack to earth. On the operator at position No. 17 inserting a plug to establish the required connection, the lamp circuit is disconnected and the lamp darkens.

It is necessary in through switching that the cord circuit condensers should not be brought into use, which would be the case if Relay R₂ (Fig. 5) were actuated. The spring of the relay is, therefore, adjusted so that the armature will not remain attracted when a current of 6 m.a. is passing through its coils.

An interesting feature of the high resistance relay is the fact that the 1,800 ohms coil is of copper and the 3,000 ohms coil of

POST OFFICE TRUNK EXCHANGE SYSTEM

Connections of Multiple Transfer Circuit.
Wiring Diagram.

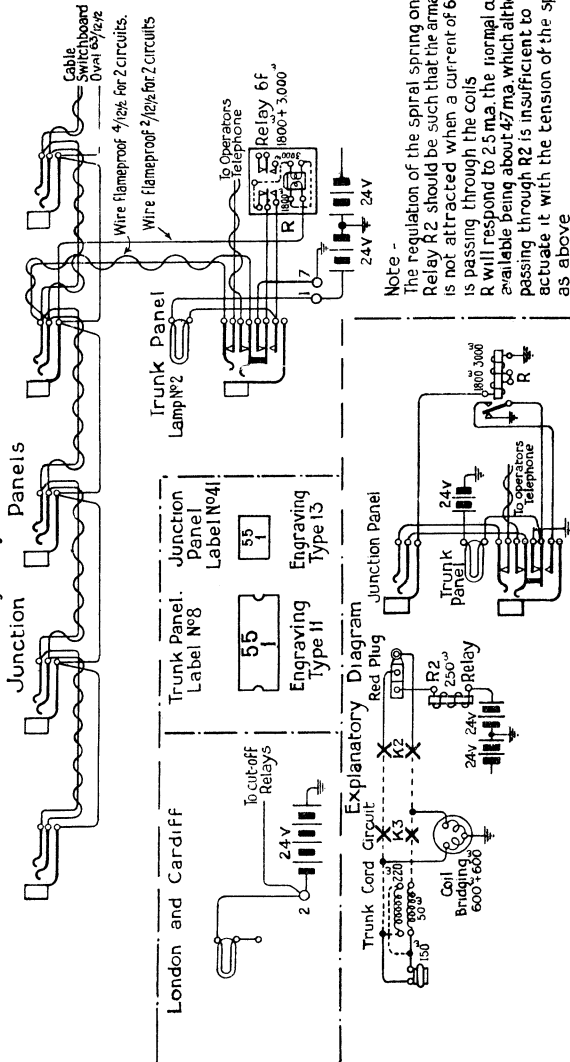

Fig. 11.

German silver wire, with the same number of turns as in a $1,000 + 1,000$ ohms relay, and the same figure of merit is thus obtained for both types.

NIGHT ALARM CIRCUIT.

The Night Alarm Circuit should now be considered (Fig. 12). A switch is fitted in a convenient posi-

POST OFFICE TRUNK EXCHANGE SYSTEM.

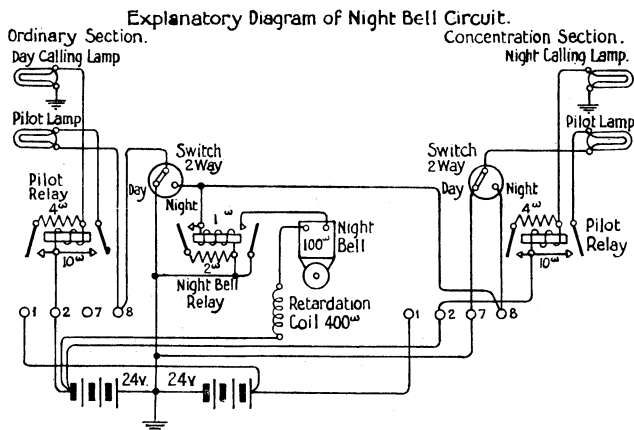

Fig. 12.

tion to the Night Concentration Sections. With the switch in the "Day" position, the current through Pilot Lamp on "Ordinary" section finds direct earth. When concentration has taken place, and the sections are not fully staffed, the switch is turned to the "Night" position, which brings the Night Bell Relay into circuit. A 24 V. battery is connected through a 400 ohm Retardation Coil to the Night Bell, which finds earth through contact of relay and armature. All switch sections in the "Concentration" group are provided with a switch 2-way No. 1, which controls the two operators' positions. This arrangement allows for the Night Bell to be cut off any particular section which is busy and is receiving continuous attention from an operator. A Night Bell circuit is provided in a similar manner on the Record Switch Section and Phonogram Switch Section.

GENERAL ARRANGEMENTS OF WIRING.

The wiring arrangements adopted for the foregoing circuits are as follows. The underground cables are laced out on the

fuse side of the Main Distributing Frame and then joined across to the Heat Coil springs by means of flame-proof twin wires, the circuits being completed through the fuses and heat coils. Between the heat coil side of the M.D.F. and the Trunk Test Board lead-covered cables are provided which are laced out to the outer springs of the top row of a strip of 40/40 5-point jacks. The inner springs are teed across by means of short wires to the inner springs of the lower row, and, by means of 42-wire switchboard cable, are completed to the Intermediate Distributing Frame. From this point they are led by means of switchboard cables to the several positions in the Switch-room. The various vertical strips on the I.D.F. accommodating the cross-connecting strips 80-tag, are allotted to suit the requirements of the Trunk Exchange under consideration. The 42-wire cables from the Trunk Test Board terminate on the Test Board strips, each cable serving 20 circuits and leaving two wires spare.

The ordinary trunk circuit switch room connections and line relay connections terminate on the vertical strips allotted for this purpose, one 42-wire cable being used for five trunk circuits, and one 42-wire cable for ten sets of line relays. The Concentration Circuits terminate on a separate strip, one 84-wire cable being appropriated for 10 circuits. The Time Check connections occupy a strip, and are joined up by a 63-wire cable for each twenty Time Checks. The arrangement allows for complete interchangeability of circuits and apparatus by means of cross-connecting wires without disturbing the cable connections.

MAINTENANCE.

The maintenance of an Exchange described must be of a high order, as the voltage used is comparatively high and the frames of the switch-sections are of iron, and earth connected; consequently a breakdown of insulation generally means a full earth fault, and the fuses at the fuseboard are blown. The insulation of the switchboard cables should be tested at regular periods, and all Relays, Keys, Switch-springs, etc., kept free from dust, dirt and damp. The cords are tested regularly with the Cord Tester No. 2. Periodic tests are also made of the concentration signalling, and Transfer Circuits. All soldering should be done in a neat and workmanlike manner. The woodwork of the sections should be polished at regular intervals, and the cable troughings and runs also cleaned out at regular periods. The satisfactory working of any Exchange depends upon the standard of maintenance being of the highest.

==== LIST OF ====

Technical Pamphlets for Workmen.

(Continued.)

GROUP E.

1. Automatic Telephone Systems

GROUP F.

1. Subscribers' Apparatus C.B.
2. Subscribers' Apparatus C.B.S.
3. Subscribers' Apparatus Magneto.
4. Private Branch Exchange—C.B.
5. Private Branch Exchange—C.B. Multiple. No. 9.
6. Private Branch Exchange—Magneto.
7. House Telephones.
8. Wiring of Subscribers' Premises.

GROUP G.

1. Secondary Cells, Maintenance of.
2. Power Plant for Telegraph and Telephone Purposes.
3. Maintenance of Power Plant for Telegraph and Telephone Purposes.
4. Telegraph Battery Power Distribution Boards.

GROUP H.

1. Open Line Construction, Part I.
2. Open Line Construction, Part II.
3. Open Line Maintenance.
4. Underground Construction, Part I.
5. Underground Construction, Part II.
6. Underground Maintenance.
7. Cable Balancing.
8. Power Circuit Guarding.
9. Electrolytic Action on Cable Sheaths, etc.
10. Constants of Conductors used for Telegraph and Telephone Purposes.

GROUP I.

1. Submarine Cables.

GROUP K.

1. Electric Lighting.
2. Lifts.
3. Heating Systems.
4. Pneumatic Tube Systems.
5. Gas and Petrol Engines.