



WS No. 19 Mark III

**This file has been down loaded from  
The Wireless-Set-No19 WEB site.**

**All files from this WEB site are free of charge.  
If you have been charged for this file then please  
contact the person you obtained it from as he/she  
has illegally obtained both the file and money they have  
charged you.....**

P.W.-D.11.

**POST OFFICE  
ENGINEERING DEPARTMENT**

---

**TECHNICAL PAMPHLETS  
FOR  
WORKMEN**

---

*Subject :*

**C.B. EXCHANGES.  
22 VOLTS.**

ENGINEER-IN-CHIEF'S OFFICE  
1919

## C.B. EXCHANGES—22 VOLTS.

(D.II.)

*The following publications in this series are of  
kindred interest:—*

- D.1. Elementary Principles of Telephony.
- D.3. Principles of Telephone Exchange Signalling.
- D.8, 9, 10 & 12. C.B. Exchanges.
- D.14. Telephone Exchange Maintenance.
- D.15. Telephone Testing Equipment.
- D.16. Routine Testing for Telephone Exchanges.
- D.18. Distribution Cases, M.D.F. & I.D.F.
- F.1. Subscribers' Apparatus. C.B.
- G.1. Secondary Cells, Maintenance of.
- G.2. Power Plant for Telegraph & Telephone Purposes.

*also*

I.P.O.E.E., Paper No. 73.

"The provision of a C.B. Telephone Exchange"  
by G. F. Greenham.

---



---

TABLE OF CONTENTS.

	PAGE
GENERAL DESCRIPTION ... ..	1
OPERATING ON "A" AND "B" POSITIONS ... ..	8
FUNDAMENTAL CIRCUIT ... ..	11
SUBSCRIBER'S INSTRUMENT ... ..	12
SUBSCRIBER'S LINE CIRCUIT .. ..	13
"A" OPERATOR'S CORD CIRCUIT ... ..	15
SERVICE REGISTERS ... ..	16
OPERATOR'S INSTRUMENT ... ..	18
ENGAGED TEST ... ..	20
JUNCTION CIRCUITS ... ..	20
KEYLESS JUNCTIONS ... ..	26
BUSY-BACK CIRCUIT ... ..	28
RINGING JUNCTIONS ... ..	29
JACK-ENDED JUNCTIONS ... ..	34

# C.B. EXCHANGES.—22 VOLTS.

## GENERAL DESCRIPTION.

The C.B. No. 1 type of switchboard is designed to meet the requirements of the largest exchanges as, in its multiple field, it is possible to accommodate 10,000 subscribers' lines.

The switchboard consists of sections of two distinct types, "A" position sections on which the subscribers' lines are terminated, and "B" position sections wired to take the incoming junctions. Each section of either type contains 3 operators' positions and 8 panels for switchboard jacks.

A typical arrangement of sections in an exchange is shown in Fig. 1, which also includes a plan of an Apparatus Room.

Fig. 2 illustrates the face equipment of an "A" operator's position.

The lowest part of the jack field in each panel is reserved for answering jacks and line lamps in rows of 10. Each lamp is placed immediately below its corresponding answering jack on the right of which provision is made for the subscriber's number. The opal caps of the line lamps are engraved and coloured to denote the service allowed to each subscriber in accordance with the official code. The number of answering jacks and lamps fitted in each panel is governed by the calling rate of the subscribers' lines which decides how many can be attended to by each operator. It varies, roughly, from 60 to 120 per position. Distribution of subscribers' lines amongst the "A" operators in order to equalise the load on each position is provided for on a standard intermediate distributing frame in the apparatus room. Cables from the multiple and from the answering jacks and lamps terminate on opposite sides of the Inter-

10061. Wt.40382/251. 5,500. 3/20. S.O.,F.Rd.

*Technical Pamphlets for Workmen.*

*Amendments January, 1928.*

### **P.W.-D.11.**

Page 1. Para. 3, line 2, amend to read: "in Fig. 1 and a plan of an Apparatus Room in Fig. 1A." 1/28

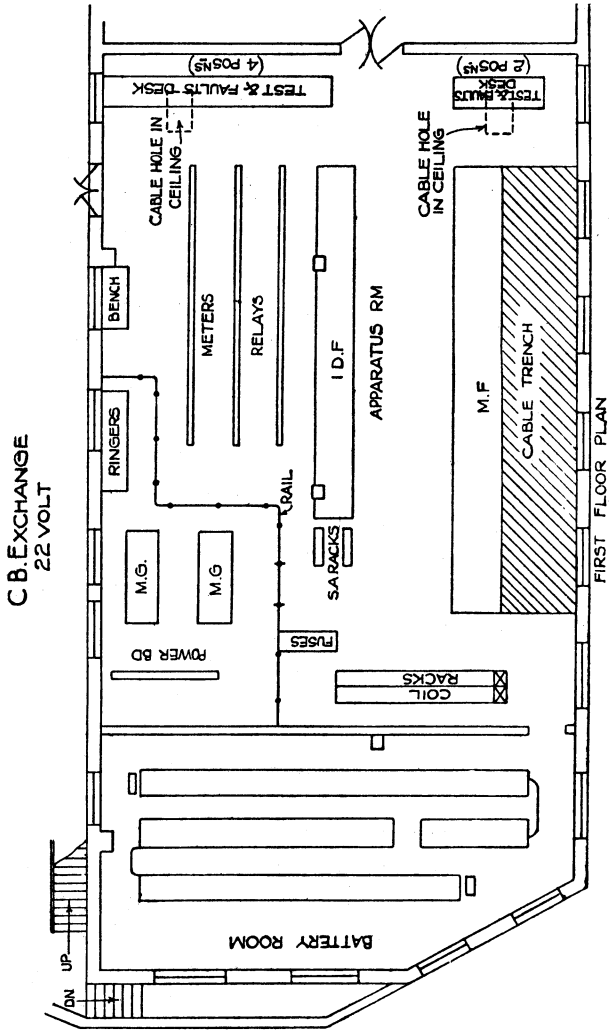

Fig. 1.

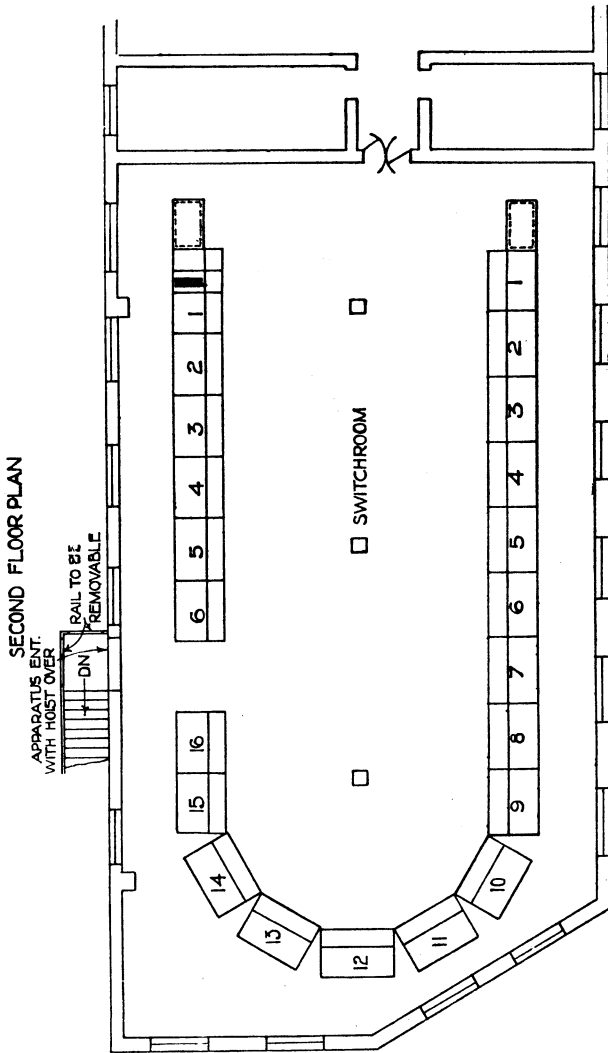

Fig. 1A.

mediate distributing frame and the lines are cross connected by means of jumper wires.

Above the answering jacks are the outgoing junction jacks, usually in rows of 10, multiplied every 6 panels, and above these, again, the strips of 20 subscribers' multiple jacks generally repeated every 9 panels.

The multiple jacks are arranged in blocks of 100 jacks numbered from 0-99, and the multiple is built upwards. At the bottom of the space reserved for subscribers' multiple in the first 9 panels of the switchboard, 9 sets of jacks, numbered 0-899, are placed, each panel containing the jacks of a complete hundred and immediately above these are fitted the jacks numbered 900 to 1,799, and so on.

At the bottom of each panel a pilot lamp is shown, this being a lamp of larger dimensions than the ordinary line lamps. The pilot lamp glows every time a line lamp lights up in the panel in which it is situated.

In addition to the pilot lamps, there are 3 other special lamps to each operator's position, viz., the Order Wire Lamp, the Instruction Circuit Lamp, and the Register Lamp.

The *Order Wire lamp* glows when the key of an order wire is depressed which controls a group of junctions to an exchange outside the normal exchange area, and draws the attention of the operator to the fact that a special fee should be charged.

The *Instruction Circuit lamp* is used by the Supervisor to call the attention of all the operators in the exchange in order to give them special information. All "Instruction" lamps glow simultaneously, and each operator goes into circuit and receives the instruction by depressing a special key. The fact of depressing the key extinguishes the lamp on that position.

The *Register lamps* glow every time a register key is depressed.

*Page 4. Para. 3. Amend first sentence to read :*

“ At the bottom of each panel a pilot lamp is shown, this having a cap of larger dimensions than that for ordinary line lamps.”

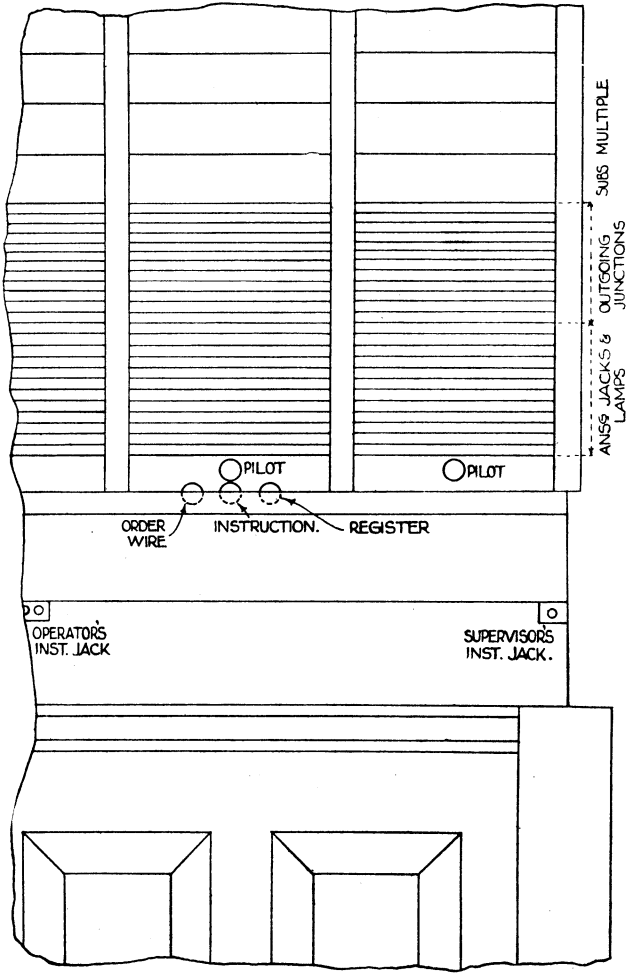

ELEVATION

FRONT VIEW OF PART OF "A" SECTION OF C.B. MULTIPLE BOARD  
SCALE: 1/7

Fig. 2.



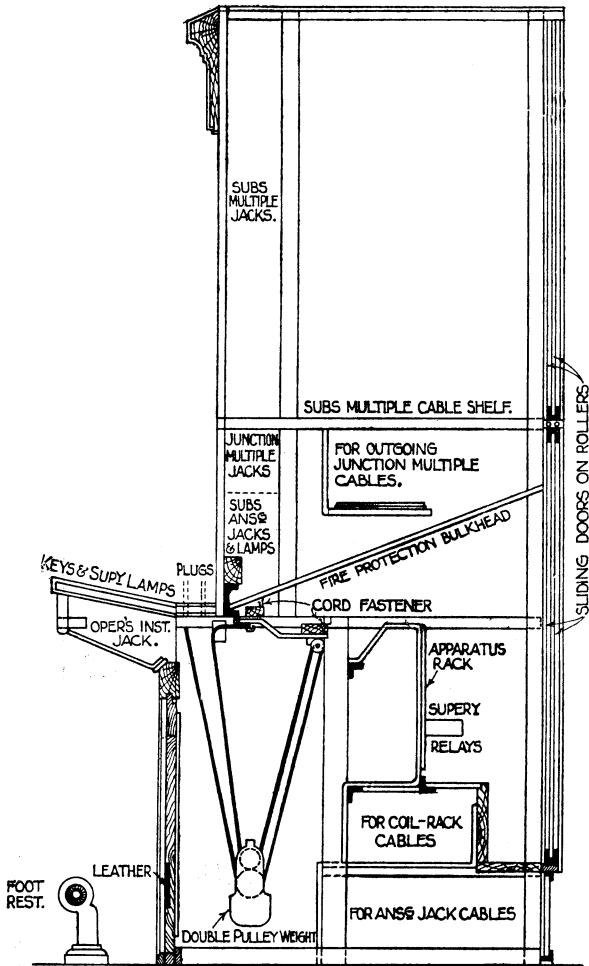

C.B. MULTIPLE SWITCHBOARD "A" SECTION.  
SCALE: 1/18.

Fig. 3.

Fig. 3 is a sectional view of an "A" section and indicates the location of some of the apparatus. The provision made for the accommodation of cables is apparent from this drawing, also the protection against the spread of fire. In addition to the fireproof shelves shown, each section is isolated from its neighbour by means of vertical fireproof panels which fill up all the spaces not occupied by the cables running horizontally.

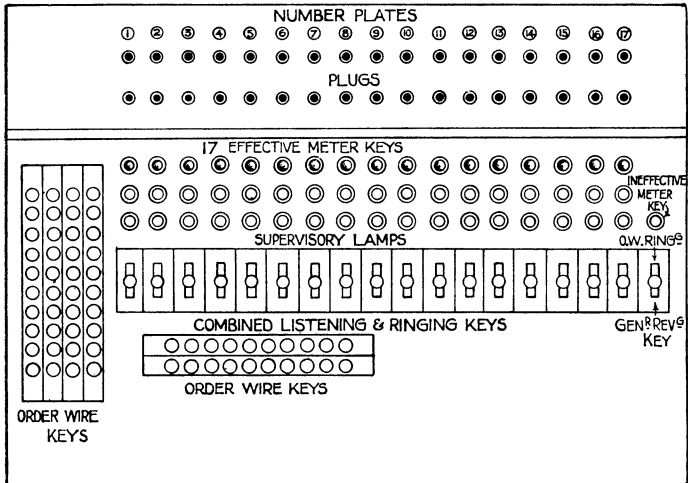

PLAN OF KEYBOARD OF C.B. SWITCHBOARD

Fig. 4.

Fig. 4 is a view looking down on the **key shelf**. It will be seen from this drawing that every position is provided with 17 pairs of cords, each controlled by a combined speaking and ringing key; also, that in connection with each pair of cords there are two supervisory lamps and an "effective" register key. The back lamp of a pair is associated with the back or answering cord, and the front lamp with the calling cord. When a plug is inserted into a subscriber's jack the corresponding lamp glows whilst the subscriber has his receiver on its rest and is immediately dimmed when it is removed.

The "effective" register key is used to register a call on a subscriber's meter for accounting purposes, and at the same time record an effective call on the operator's position meter. The key is depressed immediately before the operator takes

down the connection. Should the operator not be able to complete the connection, she depresses the "*ineffective*" register key shown at the right-hand side of the position. This operation has no effect on the subscriber's register, but it records an ineffective call on the operator's "ineffective" position meter. The records obtained on the "effective" and "ineffective" position meters are used for statistical purposes.

The *order wire keys* in strips of 10 are shown on the left of the position.

The "**B**" section is similar in dimension to the "A" section, but differs from it in the disposition of apparatus in the jack field and on the key shelves.

Each incoming junction led to a "B" position terminates on a plug and cord. Supervisory lamps are associated with each of the cords and, in some cases, ringing and speaking keys, as will be explained in detail later. In the panels of the jack field no accommodation is necessary for answering jacks and line lamps, and it is usual to multiple over the "B" sections only such outgoing junction lines as are used for lending purposes. This results in greater space being available for the subscribers' multiple jacks, and as the larger portion of the calls handled by the "B" operators are connected to subscribers' lines, advantage is taken of the additional accommodation to repeat the subscribers' multiple in every 6th panel, and so facilitate the operators' work when making connections.

#### OPERATING ON "A" AND "B" POSITIONS.

**Local calls.**—The subscriber calls the exchange by removing his receiver from its rest. The call is received by the "A" operator on a line lamp, which glows.

With the back cord of a pair the operator plugs into the answering jack associated with the lighted lamp, automatically extinguishing the latter, throws the key into the listening position, and ascertains the subscriber's requirements.

The engaged test is applied to the number required, and, if free, connection is made by means of the front cord, and the subscriber is rung by bringing the key forward to the ringing position. There is no need for the operator to remain in circuit to supervise the call, as the front supervisory lamp will glow until the called subscriber answers.

Upon completion of the conversation both subscribers "hang up," causing both supervisory lamps at the exchange to glow. This is the signal to the operator to take down the connection.

#### *Technical Pamphlets for Workmen.*

*Amendments January, 1927.*

#### **P.W.-D.11.**

Page 8. *Print of 2/26. Third para. Delete last line " and ascertains the subscriber's requirements."*

*Print of 3/20. Third para. last line. Delete the words " when making connections."*

*Print of 2/26. Seventh line from bottom should read " Subscriber is rung up by bringing the key forward to the ringing."*

Before disconnecting, the operator depresses the register key, as previously mentioned.

**Junction Calls.**—Should the calling subscriber require a number connected to another exchange, the call will be passed over a junction.

Junctions between exchanges are of two types. Where the number of junctions connecting two exchanges is small, the lines are usually worked as “ringing junctions.” At the incoming end ringing junctions are terminated either on a jack, or on a plug and cord on a “B” position having only this class of junction connected to it. Usually 24 ringing junctions are connected to each “B” position. Should a larger number of lines be necessary to carry the traffic between two exchanges, it is generally the practice to form them into groups and control them by means of Order Wires. It is often economical to work as few as 4 lines on the Order Wire system, provided that suitable arrangements exist at the incoming end. In such a case the “B” operator would have groups of lines on her position coming from perhaps 4 different exchanges, each group having its own order wire, but all the order wires being joined together on the “B” operator’s position. It is not usual to connect more than 4 groups of lines to one “B” operator’s position. In the case of a very large number of junctions between two exchanges, several groups are formed, each controlled by an Order Wire. The size of these groups is governed by the capacity of the “B” operator to handle the calls passing over them, this in turn being governed largely by the design of the “B” switchboard and the system upon which the lines are worked. Each group is connected to a separate “B” position.

Should the “A” operator at the originating exchange receive a call for a subscriber on an exchange reached by ringing junctions, she will plug into a disengaged outgoing junction jack marked with the code of the exchange required. The “B” operator at the distant exchange will receive the signal on a lamp on the key shelf. By throwing the speaking key associated with the calling lamp, the “B” operator will obtain particulars of the number required, and make the connection on the multiple by means of the cord and plug on which the incoming junction line terminates. If the position is equipped with “machine” ringing keys, the “B” operator will ring the required subscriber by pulling forward or de-

pressing the ringing key, in which position it is locked electromagnetically and the subscriber's bell will continue to ring until he removes the receiver from its rest.

If the "A" operator requires a subscriber on an exchange reached by order wire junctions, she depresses an order wire key bearing the code of the exchange required, and by so doing joins her instrument direct to an order wire, at the other end of which the "B" operator is listening continuously. The "A" operator passes the number required, and is allotted a disengaged junction in the group controlled by the "B" operator. The "A" operator finds this junction in the outgoing junction multiple, and connects to it by means of the calling cord, whilst the "B" operator inserts the junction plug into the wanted subscriber's line.

On the "B" positions at some exchanges the ringing keys are omitted, ringing current being supplied to the line automatically immediately the junction plug is inserted. As in the case of the machine ringing key, the current is cut off when the subscriber answers.

Should the "B" operator find the number required engaged, she will insert the junction plug into a "busy back" jack, which will cause a "tone" to be placed on the line, indicating to the "A" operator that the line is engaged.

When the two exchanges concerned are both worked on the C.B. system, whether the call is passed over a plug-ended ringing or order wire junction, the called subscriber, on hanging up his receiver, will cause the front supervisory lamp on the "A" operator's position to glow, and will give no signal to the "B" operator. The "B" operator will receive the clearing signal on a lamp when the "A" operator withdraws the plug from the outgoing junction jack.

In the case of jack-ended ringing junctions, the "B" operator also receives the called subscriber's clearing signal.

The foregoing facilities are obtained only when calls are passed between two C.B. Exchanges. In the case of a call between a Magneto and a C.B. exchange, it is not possible to secure all the advantages of visual supervision of calls.

### **P.W.—D.11.**

(1 page.)

Page 10, line 3, *After rest insert* In later exchanges the key has no electro-magnet, but a relay, actuated by the operation of the ringing key, takes the place of the electro-magnetic key (*see last para., page 30*).

## FUNDAMENTAL CIRCUIT.

The principal feature of the common battery system is the use of one battery to supply current to all the circuits normally connected with it, this battery being situated at the central point, namely, the exchange.

Fig. 5(a) illustrates one of the methods of applying this principle, and contains everything essential to enable one subscriber to converse with another.

A, B, C, D, are the four windings of a repeating coil, all being wound inductively on the same core.

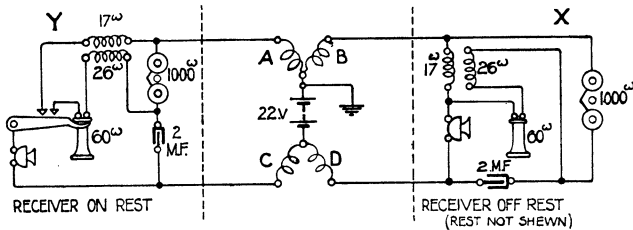

Fig. 5(a).

If the transmitter at Y be spoken into, the current flowing through it *viâ* the two arms A and C of the repeating coil will vary in accordance with the changes in the resistance of the transmitter. These current variations passing through windings A and C, will act inductively on the windings B and D, and the induced current will flow through the receiver of the telephone X. Thus the repeater acts as an induction coil, with windings A and C as the Primary, and windings B and D as the Secondary. Should the transmitter at X be spoken into, the windings B and D will function as the Primary and windings A and C as the Secondary.

A separate repeating coil is necessary for every connection set up on a C.B. switchboard, and, in consequence, one will be found in each "A" operator's cord circuit and at the incoming end of each junction wire.

Another system, but one which is not in such general use in 22-volt exchanges as the one just described, is illustrated in

Fig. 5(b). In this system the current flows out to the subscriber's instrument through retardation coils and returns through relays of similar impedance in order to maintain the balance of the circuit. The speech currents between the two subscribers' instruments are not induced from one half of the circuit to the other as in the system employing repeating coils, but pass directly through the condensers. The relays operate supervisory signals in a manner similar to the signals shown in Fig. 8.

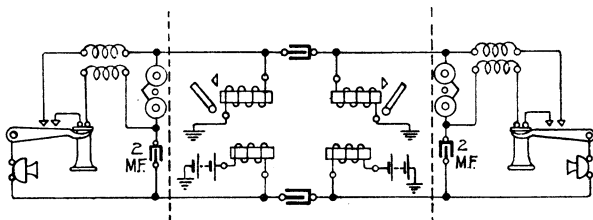

Fig. 5(b).

#### SUBSCRIBER'S INSTRUMENT.

At X and Y in Fig. 5(a) is shown the circuit of a subscriber's instrument, that at X having the switchhook eliminated in order to illustrate more clearly the connections when the receiver is off its rest.

With the receiver on the rest, the only apparatus in circuit across the line consists of a condenser and a 1,000 ohm magneto bell. The condenser prevents any flow through the instrument of current from the exchange battery, but does not interfere with the ringing of the bell when alternating current from the exchange generator is applied to the line.

When the receiver is removed from the rest, a fairly low resistance path for the exchange battery exists through the transmitter and the 17 ohm primary winding of the induction coil, and, providing that the resistance of the subscriber's line is normal, sufficient current will flow through the circuit to operate calling and supervisory signals at the exchange as will be explained later.

## SUBSCRIBER'S LINE CIRCUIT.

Fig. 6 represents in simple form the connections of a subscriber's line in a C.B. exchange.

Upon the subscriber removing his receiver from its rest, a circuit is completed which enables current to flow from the exchange battery through the 60 ohm winding of the line relay, the armature and contacts of the cut-off relay, the subscriber's line and instrument.

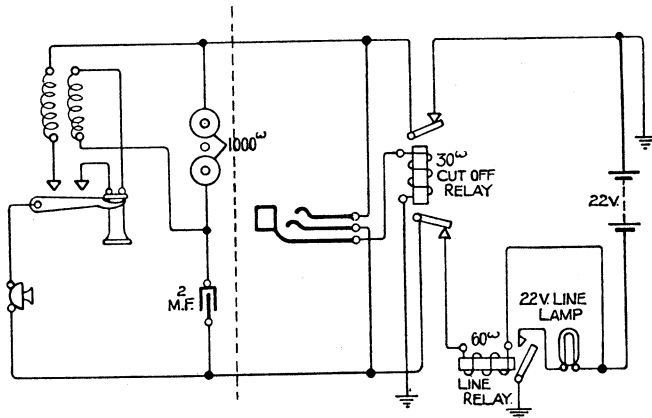

Fig. 6.

The line relay operates and closes the local circuit containing the line lamp, causing the latter to glow.

The operator plugs into the answering jack with a plug having an earthed battery connected to the sleeve as shown in the diagram of the cord circuit (Fig. 8). Immediately the sleeve of the plug comes into contact with the bush of the answering jack a circuit is formed from the battery *via* the winding of the cut-off relay to earth. This causes the cut-off relay to operate and extinguishes the line lamp by breaking the circuit of the line relay.



Fig. 7 illustrates the complete line circuit and includes several pieces of apparatus omitted from the skeleton diagram for the sake of simplicity. Among these are :—

**Multiple Jacks.**—These are arranged in parallel with the answering jacks and contain no make and break contacts.

**Pilot Lamp.**—One side of each of the line lamps fitted in any one panel of the switchboard is “commoned” and connected

### NO. 1. CENTRAL BATTERY SYSTEM SUBSCRIBER'S LINE CIRCUIT.

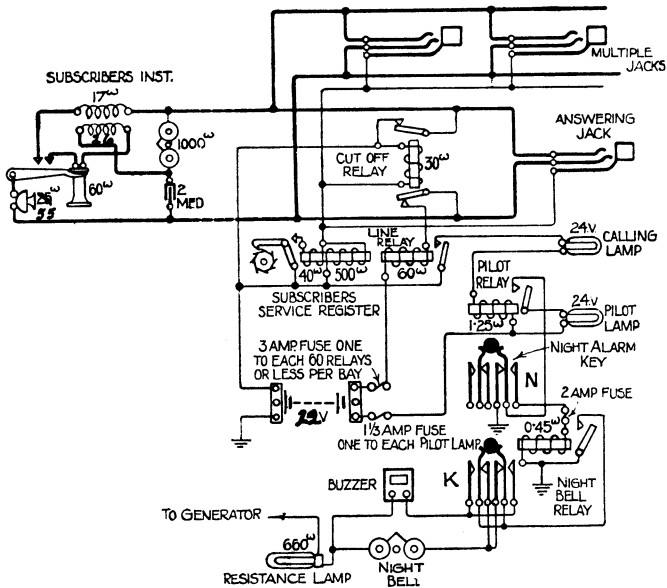

Fig. 7.

to the battery through a low resistance pilot relay. This relay is so adjusted that it will operate when one or more calling lamps are glowing, and its resistance is made low in order that it shall not interfere with the brilliancy of the lamps.

The armature of the Pilot Relay, when actuated, closes the circuit for the pilot lamp, but the current which causes this to glow passes through the night bell relay, of which there is one

to each two sections, and of lower resistance than the pilot relay. The local circuit of the night bell relay contains a buzzer and bell, either of which can be switched into circuit by means of the two-position key K. The night bell relay is short circuited during the day time by means of key N.

**Subscriber's Registers.**—These are connected in parallel with the cut-off relay and will be referred to later.

The Line and Cut-off relays are fitted on special racks in the Apparatus room.

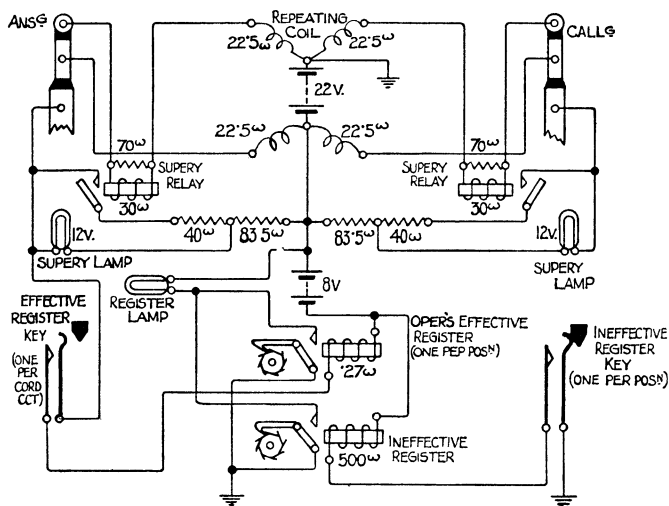

Fig. 8.

### "A" OPERATOR'S CORD CIRCUIT.

Fig. 8 illustrates the principal features of the "A" operator's cord circuit.

In the centre of the diagram is the repeating coil, the functions of which have been described already, and it will be seen that it forms a dividing line between the two halves of the circuit, keeping entirely separate the supervisory signals associated with the respective cords.

When a plug is inserted into the jack of a subscriber whose receiver is on the rest, current will flow from the negative pole of the battery *via* the  $83\frac{1}{2}$  ohms resistance, the 12-volt supervisory lamp, sleeve of plug, bush of jack, cut-off relay, to earth. The

cut-off relay will be operated and sufficient current will flow through the supervisory lamp to cause it to glow brightly. Immediately the subscriber removes his receiver from its rest, the supervisory relay will be actuated as it is in the path of the battery flowing through the subscriber's instrument. The contacts of the supervisory relay will connect a 40 ohms shunt across the supervisory lamp, reducing the current flowing through it and so darkening the filament.

Upon the subscriber restoring his receiver, the shunt is removed and the lamp will glow brightly once more, giving the operator the clearing signal.

As the supervisory relay is in the circuit of the battery feeding the subscriber's transmitter, its impedance would interfere considerably with the transmission of speech. To provide an easy path for the speech current, therefore, the supervisory relay is shunted with a non-inductive resistance of 70 ohms.

In this circuit the supervisory relay is shown in the "tip" side of the line. In some exchanges it is placed in the "ring" side, and, in consequence, is actuated by the current flowing out to the line before it passes through the subscriber's instrument.

The repeating coils are fitted on racks in the apparatus room and the supervisory relays and shunts at the back of the switch-board sections.

### SERVICE REGISTERS.

From Fig. 8, in conjunction with Fig. 7, the operation of the service registers can be followed.

The register consists of an electro-magnetic counter having an armature controlling a mechanical action similar to that of a cyclometer. All the registers are mounted on a special rack usually in the apparatus room.

The subscriber's register has two windings, one of 500 ohms and the other of 40 ohms. The 500 ohms winding is placed normally in parallel with the cut-off relay, and it is shunted by the 40 ohms winding when the register is operated in order to reduce its resistance, as will be explained.

The registers, being in parallel with the cut-off relays, receive current through their windings every time the latter are operated, but they are adjusted to remain unaffected by any current having a lower voltage than 30. The required voltage is obtained by adding 4 small cells (shown in the lower portion

of Fig. 8) in series with the main battery by the depression of the register key.

Assuming that an answering plug is in the jack of a subscriber's line, the depressing of the register key causes current to flow from the negative of the 30-volt battery (22 volts plus 8 volts) through the operator's effective register, contacts of register key, sleeve of plug, bush of jack, subscriber's register to earth.

The operator's position register and the subscriber's register both actuate and record one call, the former also closing the circuit for the register lamp previously described.

As the subscriber's register is placed in parallel with the cut-off relay, a circuit exists for the position register, and the latter will record when the key is depressed whether a subscriber's register is fitted or not. In some exchanges it is the practice only to fit subscriber's registers on the lines of Limited Rate subscribers where it is necessary to record the calls for charging purposes. In such cases the 40 ohms shunting coil is not required, but where registers are fitted to all lines the operator's position register can be so adjusted that it will not operate until the 40 ohms shunt is brought into circuit, thereby increasing the amount of current flowing. By this arrangement the operator knows for a certainty that the lighting of the register lamp means that a call has been satisfactorily registered against the calling subscriber.

The object of the ineffective register key has been explained already. It is shown in Fig. 8, and it will be seen that by the depression of the "ineffective" key, 30-volt battery flows through the 500 ohms winding of the "ineffective" register, the contacts of the key to earth. The "ineffective" key has no control over the subscriber's register, but the operation of the ineffective register closes the circuit of the register lamp, which glows as in the case of an effective call.

### **P.W.-D.11.**

Page 17. *Print of 2/26* } *Delete para. "As the sub-*  
 Page 17. *Print of 3/20* } *scriber's register . . . the calling subscriber "*  
*and insert "The subscriber's register is placed*  
*in parallel with the cut-off relay and the*  
*operator's position register is adjusted so as*  
*not to operate until the 40 ohms shunt is*  
*brought into circuit, thereby increasing the*  
*amount of current flowing. By this arrange-*  
*ment the operator knows for a certainty that*  
*the lighting of the register lamp means that a*  
*call has been satisfactorily registered against*  
*the calling subscriber."*

*Print of 2/26* } *Sixth line from bottom amend to*  
*Print of 3/20* } *read "Depression of the 'ineffective' key,*  
*current from the 30-volt battery flows," etc.*

## OPERATOR'S INSTRUMENT.

In Fig. 9 certain portions of the "A" operator's cord circuit are illustrated in order to show more clearly the connections of the operator's instrument.

The current which feeds the operator's transmitter flows from the main battery through a choking coil of 165 ohms resistance. The objects of the coil are :—

(a) To reduce the amount of current flowing through the transmitter.

(b) To prevent any high frequency stray currents from reaching the induction coil. These currents are often found on the main bus bars and take the form of noise from the dynamo commutator, cross-talk, or "kick" from the relays.

The impedance of this coil, however, would have a tendency to reduce the efficiency of the instrument by choking the current fluctuations in the transmitter, but a condenser is inserted, as shown, to provide an easy path for these currents.

The induction coil has two primary windings in parallel and two secondary windings in series, this being part of the arrangement made for the purpose of eliminating "side tone," or the hearing of the operator's own voice in her receiver. The complete arrangement can be seen in Fig. 9. The operator's receiver, in series with a non-inductive resistance of 360 ohms, is bridged across one-half of the secondary winding of the induction coil, and the circuit so formed is, in principle, exactly the same as that of the Wheatstone Bridge, the receiver taking the place of the galvanometer (see inset Fig. 9). The more nearly the line resistance approximates to the 360 ohms resistance the less will be the current flowing through the receiver, so that, under normal conditions, the receiver is only slightly, if at all, affected by the currents induced in the secondary by the primary winding, and "side tone" is consequently reduced to a minimum.

The secondary circuit of the operator's instrument is joined to the outer contacts of the speaking key (the left-hand key in the diagram), and by throwing this key the operator's circuit is connected to the calling cord and through the repeater to the answering cord. The function of the key, therefore, is simply to bridge the operator's "secondary" across the line.

The action of the ringing key follows standard practice. By bringing the lever of the "combined" key forward into the

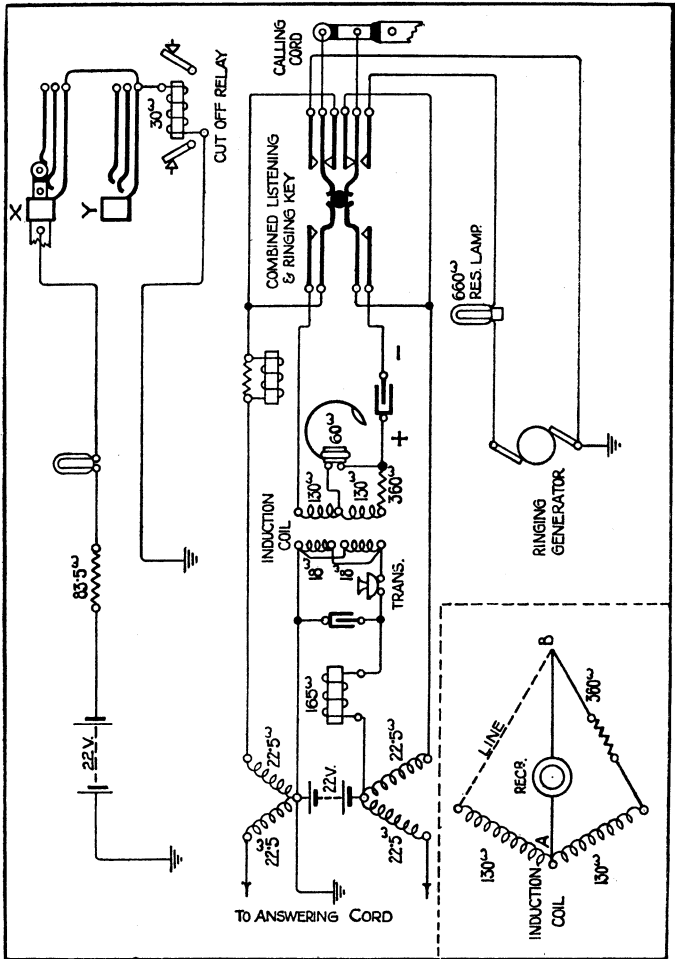

Fig. 9.

ringing position, ringing current is connected direct to the calling cord, whilst at the same time, all that part of the circuit which is "behind" the ringing key is disconnected. The ringing current is led to the outer springs of the key through a 660 ohms resistance lamp, one of which is fitted to each position. Should an operator on any position ring on a short-circuited line, the resistance of the lamp prevents the fault from affecting the ringing on any other position.

### ENGAGED TEST.

To illustrate the operation of the engaged test on an "A" position cord circuit a sketch is included in the upper part of Fig. 9 of a portion of a subscriber's line circuit. In the upper of two jacks a plug of another cord circuit is shown inserted, and as the sleeve of the plug is connected to the negative pole of the battery, the bush of the jack and those of any other jacks multiplied with it have a negative potential proportionate to the resistance of the cut-off relay.

In the secondary circuit of the operator's instrument a condenser is inserted between the speaking key and one side of the operator's receiver.

When the listening key is thrown the condenser is charged to the same potential as the battery, and, if the connections are traced, it will be seen that the side joined to the tip of the plug has positive polarity, and, of course, the other side negative polarity.

In applying the engaged test the operator taps the tip of the plug on to the bush of the jack of the required line and listens for a click. If the tip of the plug shown be tapped on the bush of the jack Y, the negative current found there will flow through the operator's receiver and reduce the difference of potential between the condenser plates, thereby causing a discharge of the condenser and a click in the receiver.

In the case of a disengaged line, the bush of the jack is at earth potential, consequently no flow of current will occur.

The condenser in the operator's secondary circuit also prevents current flowing through the receiver and induction coil when the key is thrown and so operating the supervisory signals.

### JUNCTION CIRCUITS.

A skeleton diagram illustrating the signalling arrangements of an Incoming Junction to a No. 1 C.B. Exchange is shown in Fig. 10. This represents an Order Wire controlled junction between two C.B. Exchanges, and is typical of the junctions at a large number of the exchanges in the country. At the outgoing end the circuit consists simply of a jack multiplied in the usual manner with the "tip" and "ring" springs connected

#### **P.W.-D.11.**

Page 20. *Print of 2/26* } *Amend fourth para. to read " In*  
 Page 20. *Print of 3/20* } *applying the engaged test the operator taps*  
*the tip of the plug on to the bush of the jack*  
*of the required line and listens for a click. If*  
*the tip of the plug shown be tapped on the*  
*bush of the jack Y the difference of potential*  
*between the condenser plates will be reduced,*  
*causing a partial discharge of the condenser*  
*and a click in the receiver."* 1/27

**P.W.-D.11.**

PAGE 21, Fig. 10. Delete whole of figure and insert the following:

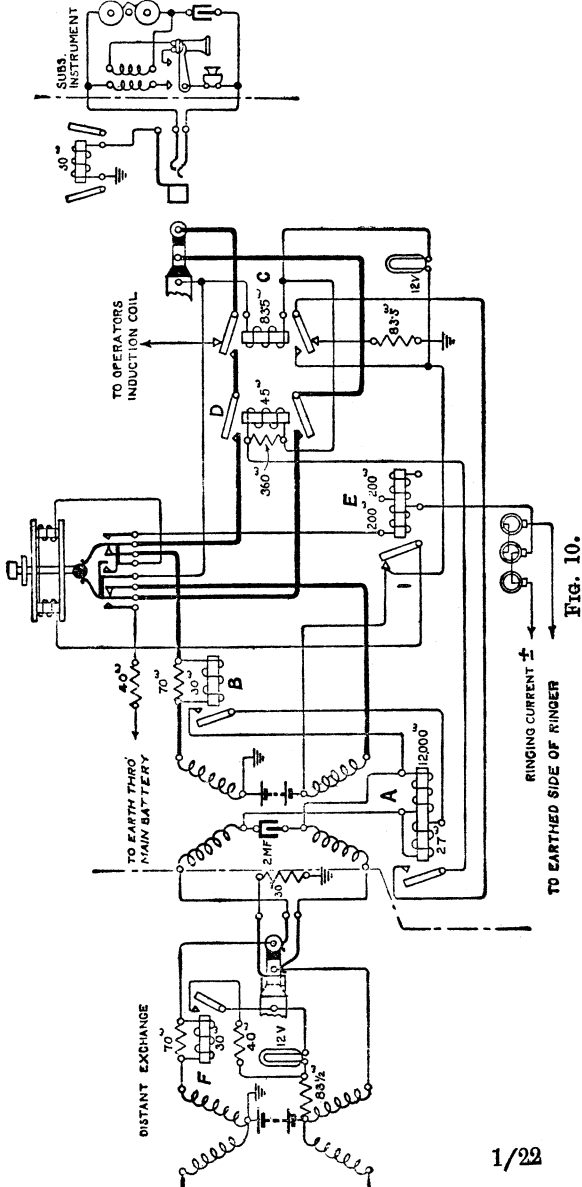

Fig. 10.



direct to the line and the bush to a 30 ohm resistance. This resistance performs the function of the cut-off relay in the ordinary subscriber's line and is necessary in the circuit of the supervisory lamp of the "A" operator's cord. It is essential also to have a resistance between the bush of the jack and earth in order that the potential of the bush on an engaged line shall be above that of the earth and so provide for the engaged test. At the incoming end, the two sides of the line are led direct to two windings of a repeating coil, and it is useful to remember that this repeating coil forms a complete dividing line between the signalling circuits of the "A" and "B" operators' positions respectively, speech being passed through the coil inductively. A condenser is inserted between the inner ends of the incoming side of the repeater to provide an easy path for the speech currents whilst allowing the A and B lines to be used as required for signalling purposes.

In order that the functions of the various pieces of apparatus included in the circuit may be seen more readily, each phase of the operating will be considered separately.

(1) **The "A" operator having been allotted a junction by the "B" operator, has plugged into an outgoing junction jack. The "B" operator has not connected.** Current flows from the negative pole of the battery at the originating exchange, passes out to the "B" line through an arm of the "A" operator's repeater, thence through one arm of the repeating coil at the incoming end, 12,000 ohms winding of relay A, another arm of the incoming repeater, the "A" line, the supervisory relay, and an arm of the repeating coil in the "A" operator's cord circuit to earth. Relay A operates and current then flows from the negative of battery at the incoming end through the 12-volt supervisory lamp on the "B" position, winding of relay D, armature and contact of relay A, armature and outer contact of relay C,  $83\frac{1}{2}$  ohm resistance to earth.

The supervisory lamp glows, thus drawing the attention of the "B" operator to the fact that the junction has been engaged at the distant end. Should the glow occur on the lamp of a line which has not been allotted, the "B" operator is made aware of the fact that a wrong junction has been taken by the "A" operator. Relay D is actuated but has no effect on the circuit at this stage.

The current which operates the 12,000 ohm relay also passes through the supervisory relay F in the "A" operator's cord circuit, but is insufficient to draw up its armature. The "A" operator's supervisory lamp therefore glows.

(2) **The "B" operator applies the engaged test.** Should the wanted subscriber be engaged a current will be found on the bush of the jack as previously described and, if the tip of the junction plug be applied to it, there will be a flow of current through the armature and top contact of relay C, the 40 ohm

winding of the induction coil to earth (see Fig. 11). This induces a current in the 234 ohm winding, which latter is bridged across the receiver, consequently a click is heard.

(3) The "B" operator plugs into jack of required subscriber's line and rings. In (1) it was seen that relays A and D were operated. In plugging into a jack, relay C is also actuated, current flowing from the battery through the supervisory lamp, winding of relay C, sleeve of plug, cut off relay in subscriber's line, to earth. The movement of the lower armature of relay C breaks the circuit of relay D, which found a path to earth through the  $83\frac{1}{2}$  ohm resistance, but remakes it by a circuit from the battery, inner contact and lower armature of relay C, contacts of relay A, winding of relay D, winding of relay C, sleeve of plug and cut off relay of subscriber's line. At the same time the winding of relay D has become a shunt to the supervisory lamp and this will in consequence be dimmed.

The position now is:—

"A" operator's supervisory lamp glowing.

"B" operator's supervisory lamp not glowing.

Relays A, C and D operated.

It will be seen that if the junction is not engaged at the distant end, the contacts of relay A will be open and, in consequence, the circuit will not be complete for relay D. The object of this arrangement is to ensure that the called subscriber be not rung until connection is made to the junction by the "A" operator, as, until relay D is operated, the ringing key is disconnected from the junction plug.

Assuming that the junction is engaged at the outgoing end, the depression of the ringing key causes the earthed ringing current to pass through the interrupter (which connects up alternately ringing current for 3 seconds and battery for 3 seconds), one winding of relay E, contacts of ringing key and of relay D, to line, through the subscriber's bell and condenser and back through the contacts of relays C and D and the ringing key to earth. The subscriber's bell is rung, but owing to the resistance offered by the bell and condenser in the subscriber's instrument, insufficient current passes through relay E to operate it.

The depression of the ringing key also closed the contacts on the two inner springs of the key which completed a circuit for the battery *via* the outer contact and armature of relay E, winding of electromagnet, ringing key contacts, sleeve of plug, bush of jack, cut off relay, to earth. The current flowing through the electromagnet energises it and causes it to hold the ringing key in the operated position. Immediately the subscriber removes his receiver from its rest, the low resistance path provided through the transmitter and induction coil enables sufficient current to flow through relay E to operate it. This

### **P.W.-D.11.**

Page 23. *Print of 2/26. Fourth para. Amend first three lines to read* "Assuming that the junction is taken up at the outgoing end, the depression of the ringing key causes the interrupted ringing (0.4 second ringing current : 0.2 second disconnection : 0.4 second ringing current : 2 seconds earth) to pass through." 1/27

### **P.W.-D.11.**

PAGE 23, para. 4. *Delete para. and insert the following:—*

Earth is connected over the A line for the 2 seconds period during which the ringing is interrupted, in order to provide for the operation of relay E should the subscriber remove his receiver during one of the intervals. Battery for this operation is supplied *via* the 40<sup>ω</sup> spool, contacts of ringing key, and B line.

breaks the circuit of the electromagnet, causing the key to fly back to its normal position and so to disconnect the ringing current.

Battery is connected during the 3 seconds' period in which the ringing is interrupted in order to provide for the operation of relay E should the subscriber remove his receiver during one of the intervals. In some exchanges the ringing current is applied to the "tip" side of the line and returns over the "ring" side, finding earth through the main battery. In such a case the interrupter connects earth instead of battery during the intervals of ringing.

In addition to "tripping" the ringing current, the removal of the subscriber's receiver from its rest provides a circuit for current to flow through relay B, which, upon operating, joins the 27 ohm coil of relay A in parallel with the 12,000 ohm winding. This, by providing a path of sufficiently low resistance, allows relay F in the "A" operator's cord circuit to operate and so darkens the supervisory lamp.

(4) **Subscribers complete their conversation and "hang up."** The calling subscriber's clearing signal is received on the "A" operator's answering cord supervisory lamp as in the case of a local call.

The called subscriber, upon restoring his receiver to the rest, breaks the circuit of relay B, which removes the 27 ohms shunt from the 12,000 ohm winding of relay A, thereby increasing the resistance in the circuit containing relay F. Relay F releases and the "A" operator's supervisory lamp glows.

The "A" operator takes down the connection and relay A releases its armature, thus breaking the circuit of relay D which was in shunt with the supervisory lamp. The supervisory lamp glows and gives the clearing signal to the "B" operator. The "B" operator withdraws the junction plug and the circuit is restored to normal by the releasing of relay C. The 360 ohm non-inductive shunt to relay D is provided to reduce the inductance in the local circuit containing this relay and so prevent sparking at the contacts of relay A when the armature releases.

At some exchanges no fewer than 5 ringing keys are fitted to each junction on the "B" position for the purpose of providing selective ringing for "4-party" party lines as well as direct ringing for ordinary subscribers.

#### ORDER WIRE.

The manner in which the order wires are connected to the position in shown in Fig. 11. Four break jacks are fitted in front of the "B" operator, the inner springs of which are connected to test jacks on the main frame. Thus order wires from 4 or less separate exchanges can be connected direct to the "B"

#### P.W.-D.11.

**PAGE 24.** *Delete para. 1 and insert the following :—*

Assuming that the junction is taken up at the outgoing end, the depression of the ringing key causes the interrupted ringing (1 second ringing current and 2 seconds earth) to pass through one winding of relay E, contact of ringing key, contacts of relays D and C, out to A line, through the subscriber's bell and condenser, returning by the B line through contacts of relay D and ringing key, through 40<sup>ω</sup> spool to battery and earth. The subscriber's bell is rung, but owing to the resistance offered by the bell and condenser in the subscriber's instrument, insufficient current passes through relay E to operate it.

*Page 24. Print of 2/26. Ninth line. Delete "Tipping" and insert "Tripping." 1/27*

*Page 28. Print of 2/26. Second line. Delete the words "Fig. 14" and insert "Fig. 13." 1/27.*

INCOMING O.W. & 'B' OPERATORS TELEPHONE CIRCUIT

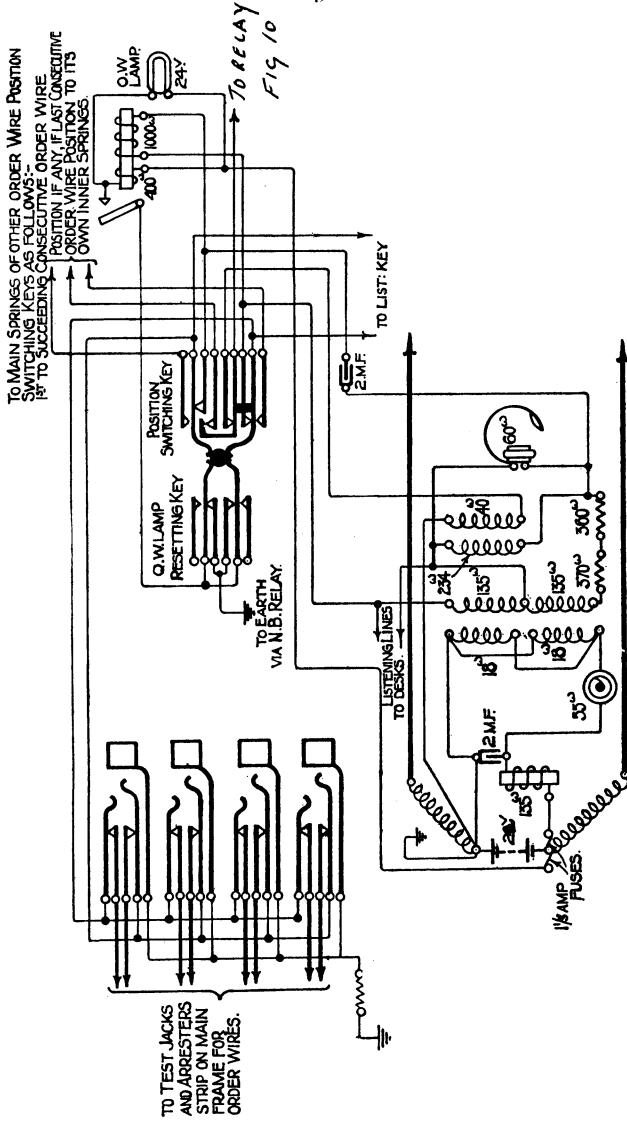

Fig. II.

operator's position. The outer springs of the jacks are "commoned" and are joined to the operator's instrument through a position switching key which provides for the coupling of 2 or more positions during slack periods. The object of the break jacks is to enable the "B" operator to replace a faulty order wire by inserting a plug of one of the junctions on her position into the jack of the faulty line.

An order wire calling lamp is provided to gain the attention of the "B" operator when the position is not "staffed." A 1,000 ohm relay is bridged across the order wire and responds to a generator ring from the distant end. The armature of the relay closes the circuit for the calling lamp and of the 400 ohm retaining coil of the relay which locks the armature until the resetting key is thrown by the operator and the circuit broken.

### KEYLESS JUNCTIONS.

In the most modern of the C.B. exchanges the ringing key on order wire junctions is dispensed with, the ringing of the required subscriber being started automatically upon the insertion of the junction plug into the multiple jack. A saving in the time of the "B" operator is effected by this arrangement, which enables her to control a greater number of junctions.

A typical order wire keyless junction circuit is shown in Fig. 12, but as the signalling arrangements are similar to those of Fig. 10 only the ringing circuit will be described.

Upon the junction plug being inserted into the jack of the required line, relay C is operated. If the "A" operator at the distant end has engaged the junction and actuated relay A (see Fig. 10), relay D will also be operated as a circuit is complete from the battery, winding of relay D, contacts of relays F, E, C and A, winding of relay C, cut off relay in subscriber's line, to earth.

Relay D is in shunt with the supervisory lamp causing it to be dimmed.

The closing of relay D allows ringing current to flow *via* relay E, contacts of relay D, B line, subscriber's bell, A line, contacts of relays C and D to the earthed side of the ringing generator.

The removal of the subscriber's receiver from its rest enables sufficient current to flow through relay E to actuate it. Relay F, which was short-circuited by the contacts of relay E, will

# INCOMING KEYLESS O.W. JUNCTION FROM C.B. EXCHANGE

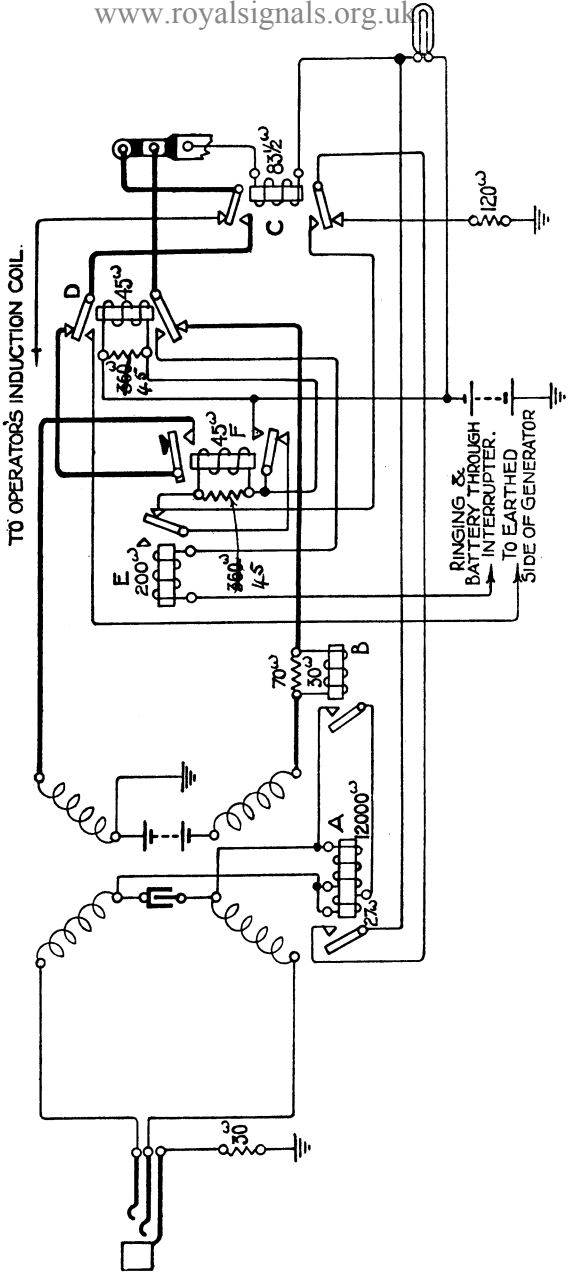

Fig. 12

now operate as it is momentarily placed in series with the winding of relay D. The closing of the contacts of relay F short-circuits relay D but locks relay F in the operated position, current flowing from the negative of battery, contact and winding of relay F, contacts of relays C and A, winding of relay C, cut off relay, to earth. Relay D releases and disconnects the ringing current, at the same time joining the junction plug to the rest of the circuit and so allowing relay B to operate. Relay F, which replaces relay D as a shunt to the supervisory lamp, remains operated until the operator at the distant end disconnects and causes the contacts of relay A to open. The removal of the lamp shunt gives the clearing signal to the "B" operator.

To guard against subscribers being rung in error, the ringing cannot be started until the junction is engaged at the outgoing end as relay D does not operate until the contacts of relay A are closed.

Should the called subscriber leave his telephone he can be recalled if required, by withdrawing the junction plug and re-inserting it.

### BUSY BACK CIRCUIT.

When the number tested by a "B" operator on an order wire junction position is engaged, she notifies the "A" operator at the distant exchange of the fact by inserting the junction plug

#### BUSY BACK CIRCUIT FOR JUNCTION WORKING.

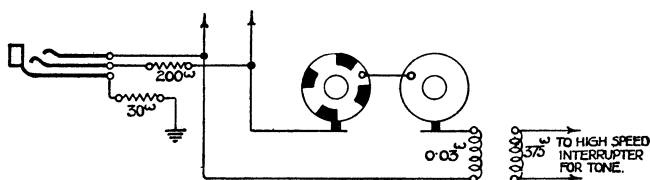

Fig. 13.

into a busy back jack fitted in the multiple field of her position, which connects an interrupted tone to the line. The circuit of the busy back is shown in Fig. 13. The tone is produced by a high speed interrupter in circuit with an induction coil and battery and it passes to the busy back jack *via* a slow speed interrupter.





A diagram of a ringing junction circuit used in the latest C.B. No. 1 Exchanges of 22 volts is shown in Fig. 15, and attention is drawn to the points of difference with the circuits previously described.

The 12,000 ohm relay is replaced by one of 50 ohms (A) having one side earthed. This relay responds to the current from the "A" operator's cord circuit and completes the circuit for the calling lamp in a similar manner to the 12,000 ohm relay in Fig. 14. The supervisory relay (B), which is actuated by the removal of the called subscriber's receiver, is joined to the inner side of the repeating coil, and both relays A and B are balanced by coils of the same impedance as the relays in order that the circuit may be kept free from disturbance.

The advantages of connecting relay A to one side of the line only are :—

(1) As the signalling current from the Originating exchange finds "earth" at the Incoming exchange the resistance of only one-half of the line is encountered and signalling on long lines can be effected without difficulty.

(2) The supervisory relay in the "A" operator's cord circuit is operated by current sent over the A line from the Incoming end *viâ* the contacts of relay B and one of the impedance coils. This allows the use of larger currents and, in consequence, the signalling circuit is not so sensitive to the conditions of the line as in the circuits employing the 12,000 ohm relay.

It will be observed that it is necessary for the "A" operator's supervisory relay to be placed in the "A" line, consequently this circuit cannot be used, without modification, in conjunction with exchanges in which the supervisory relay is in the "B" line.

Fig. 15 also illustrates the latest form of key ringing. When the plug is inserted into a multiple jack, relay C is operated and earths the outer contacts of the ringing key. Upon the operator depressing this key the circuit is closed for relay D, which actuates and locks as the earth, which was connected to one side of the coil by the ringing key, remains, after the key is released, *viâ* the top armature of relay D, contacts of relay E, the speaking key and the bottom armature of relay C. The lower of the two upper armatures of relay D connects ringing to the subscriber's line until relay E is "tripped" and breaks the locking circuit of relay D. This form of machine ringing requires less apparatus on the key shelf, and is therefore preferable to the system which contains an electro-magnetic locking device.

LINES INCOMING FROM C.B. C.B.S.& TRUNK EXCHANGES.

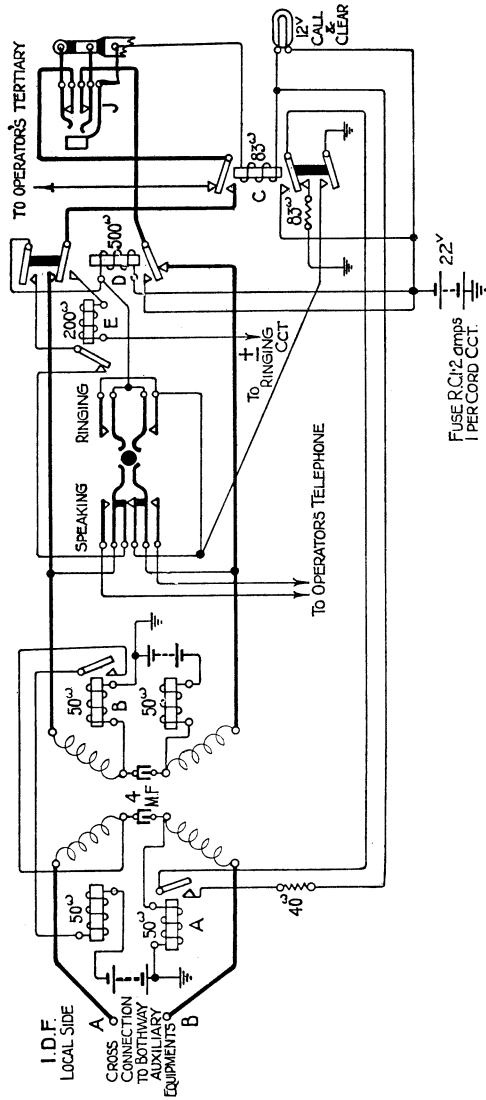

Fig. 15.

When this circuit is used in connection with junctions from a Trunk Exchange an "interrupt jack" (J) is fitted to each line for the purpose of challenging engaged subscribers and offering them trunk calls when the call has come over a long trunk line.

A special cord is used for challenging and, usually, two are fitted to each position. A diagram of the circuit of a challenging cord used in connection with a C.B. system having the supervisory relay in the "tip" side of the "A" operator's cord circuit is shown in Fig. 16.

Upon ascertaining, by means of the engaged test, that the subscriber required for a trunk call is engaged, the "B" operator inserts the challenging plug into the "Interrupt" jack of the junction from the Trunk Exchange and then plugs the junction cord into the required subscriber's line.

The apparatus in Fig. 16 must now be regarded as in shunt with an "A" operator's cord circuit (Fig. 8). Relay C will operate and join together the inner ends of one side of the repeating coil, thus completing the circuit of the "B" operator's instrument and allowing her to challenge the engaged subscriber. Relay C also closes the circuit for the lamp.

If the required subscriber accepts the call, the "B" operator depresses the flashing key. This breaks the circuit of relay C, which releases and disconnects the operator's telephone. Relay E actuates and retains the Earth on one side of the lamp which was broken when relay C released, and closes the circuit for relay A. Relay A operates and causes relays B and D to attract their armatures. Owing to the low resistance of relay B practically all the current which was passing through the subscriber's telephone and returning to the Exchange *via* the "A" operator's supervisory relay is now "side tracked" and finds earth through relay B. The "A" operator's supervisory relay would release, therefore, but for the fact that it now receives current *via* the lower armature of relay D. The upper armature of relay D is connected to an interrupter which connects Earth for .75 second with an interval of .75 second, and as the armature is closed relay F responds to the interruption. Every time that relay F closes, Earth is connected to the "tip" side of the line and the "A" operator's supervisory relay is short-circuited. The intermittent flashing of the lamp which results is a signal to the "A" operator, who thereupon takes down the connection. This causes relay B to release and removes the Earth from relays D and E. Relays D and E are now in series and current is flowing through them to Earth *via* the cut-off relay in the subscriber's line. The amount of current flowing is insufficient for relay D to hold its armatures, consequently these release and, as the contacts of relay E are still made, a circuit is completed for the lamp, causing it to glow and give the signal to the "B" operator to withdraw the challenging plug.



### JACK-ENDED JUNCTIONS.

Except in the case of the largest C.B. exchanges, it is now the practice to terminate ringing junctions on jacks instead of plugs at the Incoming end. This allows them to be operated in a similar manner to subscribers' lines and enables both subscribers' and junction circuits to be terminated on the same position, an arrangement which offers considerable advantages from a traffic point of view.

Fig. 17 (a) is the circuit of a both-way jack-ended junction, and Fig. 17 (b) the latest form of cord-circuit which is suitable

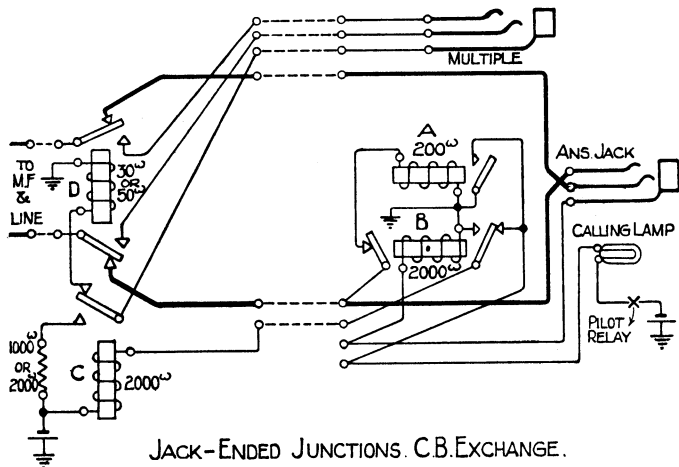
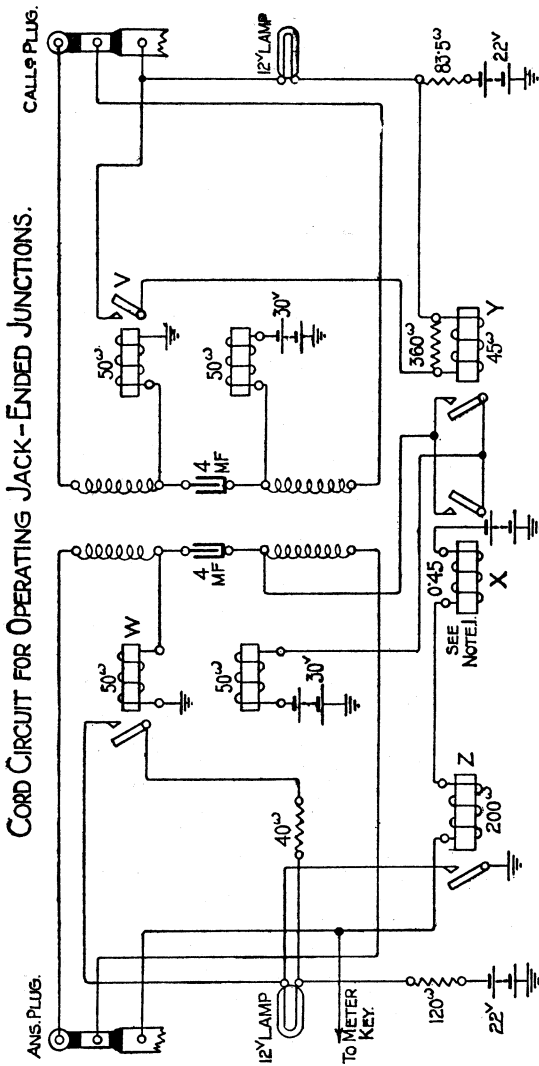

Fig. 17(a).

for dealing with either local calls or calls received over jack-ended junctions.

When an "A" operator at the distant end plugs into the junction, current flows over the "B" line *viâ* the contacts of relays D and B, and operates the line relay A. This closes the circuit for the calling lamp, causing it to glow and at the same time completing a circuit for relay C, which actuates and places an engaged test current on the bushes of all the outgoing multiple jacks.

Upon the operator at the incoming end plugging into the answering jack with the answering plug (Fig. 17b), the cut-off relay B (17a) operates as in the case of a local call, the current passing from the battery and relays X and Z (17b), the bush of jack, and relay B to Earth (17a). This breaks the circuit of relay A, which releases and extinguishes the calling lamp.



Relay D actuates when the circuit is used for outgoing calls by current flowing from the cord circuit *viâ* the bush of the multiple jack. When operated, relay D cuts off all that part of the circuit used for incoming calls.

When the cord circuit (17b) is used for local calls, relay X operates, as the low resistance of the cut-off relay in the subscriber's line allows sufficient current to pass through it to cause it to attract its armature, but there is insufficient current to cause it to operate when the 2,000 ohm cut-off relay B (17b) in the jack-ended junction is in circuit.

With relay X operated, the signalling arrangements of the cord-circuit are similar in principle to circuits already described, except that the answering plug supervisory lamp is not directly in circuit with the sleeve of the plug but in a local circuit of relay Z, this arrangement being part of the circuit provided to give a "through" clearing signal, as will be explained.

When an answering plug is inserted into the answering jack of a jack-ended junction, the current coming over the "B" line from the distant end passes through the reversed wiring on the answering jack (17a), and so through the "tip" of the plug and the supervisory relay W to Earth (17b). The operation of this relay places a shunt across the supervisory lamp and extinguishes it. Relay X does not operate, consequently current is not sent back over the "A" line of the junction.

With the calling plug inserted into the jack of the "called" subscriber, the calling supervisory lamp will glow as in the case of an ordinary cord circuit, and it will be extinguished immediately the subscriber removes his receiver from its rest, as this will cause relay V to operate and connect relay Y in shunt with the lamp. The current passing through relay Y operates it and so causes current to flow through one of the impedance coils, the contacts of relay Y, one arm of the repeating coil, the reversed wiring of the answering jack, the "A" line, and to Earth *viâ* the supervisory relay in the "A" operator's cord circuit (Fig. 8). This extinguishes the lamp in front of the "A" operator. Upon the called subscriber "hanging up," relay V is released, which breaks the circuit of relay Y, causing the supervisory lamp to glow by removing the shunt and breaking the circuit of the current which was flowing over the line to the originating end. This releases the "A" operator's supervisory relay (Fig. 8) and gives her the clearing signal. When the originating "A" operator withdraws the plug from the junction, relay W (Fig. 17b) releases and removes the shunt to the answering supervisory lamp. This glows, therefore, and as the calling supervisory lamp is also glowing, the operator takes down the connection.

==== LIST OF ====

# Technical Pamphlets for Workmen.

=====

## GROUP A.

1. Magnetism and Electricity.
2. Primary Batteries.
3. Technical Terms.
4. Test Boards.
5. Protective Fittings.
6. Measuring and Testing Instruments.
7. Sensitivity of Apparatus.

## GROUP B.

1. Elementary Principles of Telegraphy and Systems up to Morse Duplex.
2. Telegraph Concentrators.
3. Wheatstone. Morse Keyboard Perforators.
4. Quadruplex. Telegraph Repeaters, Sx., Dx., and Quad.
5. Hughes Type-printing Telegraph.
6. Baudot Multiplex.
7. Western Electric Multiplex. Murray Multiplex. Other Systems.
8. Fire Alarm Systems.

## GROUP C.

1. General Principles of Wireless Transmission and Reception.

## GROUP D.

1. Elementary Principles of Telephony.
2. Telephone Transmission. "Loading." Telephone Repeaters and Thermionic Valves.
3. Principles of Telephone Exchange Signalling.
4. Magneto Exchanges—Non-Multiple Type.
5. Magneto Exchanges—Multiple Type.
6. C.B.S. Exchanges—Non-Multiple Type.
7. C.B.S. Exchanges—Multiple Type.
8. C.B. Exchanges—No. 9 Type.
9. C.B. Exchanges—No. 10 Type.
10. C.B. Exchanges—No. 12 Type.
11. C.B. Exchange—22 Volts.
12. C.B. Exchanges—40 Volts.
13. Trunk Telephone Exchanges.
14. Telephone Exchange Maintenance.
15. Telephone Testing Equipment.
16. Routine Testing for Telephone Exchanges.
17. Internal Cabling and Wiring.
18. Distribution Cases, M.D.F. and I.D.F.
19. Cord Repairs.
20. Superposed Circuits, Transformers, etc.
21. Call Offices.

[Continued on page iv. of Cover.]



==== LIST OF ====

# Technical Pamphlets for Workmen.

(Continued.)

---

## GROUP E.

1. Automatic Telephone Systems

## GROUP F.

1. Subscribers' Apparatus C.B.
2. Subscribers' Apparatus C.B.S.
3. Subscribers' Apparatus Magneto.
4. Private Branch Exchange—C.B.
5. Private Branch Exchange—C.B. Multiple, No. 9.
6. Private Branch Exchange—Magneto.
7. House Telephones.
8. Wiring of Subscribers' Premises.

## GROUP G.

1. Secondary Cells, Maintenance of.
2. Power Plant for Telegraph and Telephone Purposes.
3. Maintenance of Power Plant for Telegraph and Telephone Purposes.
4. Telegraph Battery Power Distribution Boards.

## GROUP H.

1. Open Line Construction, Part I.
2. Open Line Construction, Part II.
3. Open Line Maintenance.
4. Underground Construction, Part I.
5. Underground Construction, Part II.
6. Underground Maintenance.
7. Cable Balancing.
8. Power Circuit Guarding.
9. Electrolytic Action on Cable Sheaths, etc.
10. Constants of Conductors used for Telegraph and Telephone Purposes.

## GROUP I.

1. Submarine Cables.

## GROUP K.

1. Electric Lighting.
2. Lifts.
3. Heating Systems.
4. Pneumatic Tube Systems.
5. Gas and Petrol Engines.