

WRITTEN
and illustrated by Mark Lane using
information contained in documents from
the **Wireless-Set-No.19** website archive
www.royalsignals.org.uk ©2011

USER HANDBOOK

for

LARKSPUR II

RADIO CONTROL HARNESS

Reprinted Sep 74 incorporating Amdt 1 to 6 inc

**Published under the authority of
Signal Officer in Chief (Army)
Ministry of Defence
S.W.1**

1973

AMENDMENT RECORD

Amendment Number	By whom amended	Date of insertion
0	N/A	1/2/1973
1	Incorporated In reprint	26/4/1973
2		25/5/1973
3		4/6/1973
4		3/11/1973
5		12/4/1974
6		8/9/1974
7		
8		
9		
10		
11		
12		
13		
14		
15		
16		
17		
18		

Amendment Number	By whom amended	Date of insertion
19		
20		
21		
22		
23		
24		
25		
26		
27		
28		
29		
30		
31		
32		
33		
34		
35		
36		
37		

Contents

<u>Section</u>		<u>Page</u>
CHAPTER 1 - GENERAL DESCRIPTION		
1	Purpose and Facilities	1
2	A vehicle installation	4
3	B vehicle installation	6
CHAPTER 2 - USING THE HARNESSSES		
4	Preparation	7
5	Operation	7
	Larkspur II items	8b
6	Bibliography	9

ILLUSTRATIONS

<u>Fig No.</u>		<u>Page</u>
1	Helmet, Headset electrical	3
2	Commander's personal unit	5
3	Crewman's personal unit	5
4	RSB2	6
5	Example B harness	8
6	Example A harness	8a

Chapter 1 - General Description

1. Purpose and Facilities

The Larkspur II system has been introduced into service as an interim upgrade to provide the same facilities as the Clansman radio harness until such time as it is considered feasible to introduce the Clansman system across the A and B vehicle fleets. The use of the Larkspur II system will allow the introduction of the Helmet, Headset Electrical, 'A' vehicle into service allowing crews of armoured vehicles to achieve familiarity with the use of combined headset and microphone items. It will be noted that in order to avoid unnecessary redundancy of equipment already in service, Microphones Hand SI No.1A and No.6 can still be used by crewmen in both A and B harness types, Microphones, Magnetic, SI No.3 and No.5 can still be used by commanders of vehicles fitted with type A harness systems and Microphones, Magnetic, SI No.4 and No.7 can still be used by commanders of vehicles fitted with type B harness systems.

Unlike the Larkspur II upgrade for A type harnesses, which requires items to be sent to REME units for internal alteration, the upgrade for B type harnesses is restricted to the removal and replacement of the J2 box with the RSB2 box (no provision is made for vehicles using the J1 box) and could be achieved by competent vehicle crews.

The Larkspur II system provides the following functions additional to those already provided by the Larkspur system:

- a) Use of helmet headset and split earphone working for all crew members. Previously split earphone working has only been available to commanders of A vehicles.
- b) Live microphone on intercom. Previously live microphone on intercom has only been available to commanders of A vehicles.
- c) Crew monitor. Previously only commanders of A vehicles have had monitor facilities.
- d) Voice call. Due to split headphone working all crew members can now hear intercom in at least one ear irrespective of individual selections.

The commander's personal unit is similar in size and shape to the chest plate of the the Microphone, Magnetic, SI No.5 or 7 but has no attached microphone or connecting tinsel and is made from metal. The commander's personal unit for both A and B harnesses is identical, simplifying logistics. The commander's personal unit has 2 switches; one 4 position switch which controls radio/intercom selection and one 3 position switch which controls Monitor and Battle Intercom settings. The monitored radio set is heard in the commander's right ear.

The crewman's personal unit is the same as the commander's personal unit with 2 exceptions; the 4 position switch controls live intercom and monitor settings and the 3 position switch is replaced with a rotary gain control as the line used to provide the monitor facility was previously used as the voltage control relay line and, as such, there is no gain control fitted to this line on the crew boxes of either the A or the B harness systems. The monitor facility is provided to the right ear.

The use of the term Battle Intercom in relation to the commander's personal unit, rather than Live intercom, is to indicate that the commander's personal unit functions in the same way as the Microphone, Magnetic, SI No.5 in relation to the Intercom setting i.e. simply switching to the Intercom automatically provides the Live intercom facility. When the pressel switch is operated with the four way switch in the Intercom position the Voice Call facility is operated. The following table shows the effects of the various switch settings on the commander's personal unit for the crew when they are working one of the radios.

Pressel OFF

4 way switch	3 way switch	Crew hears
A	O	radio
A	M	radio
A	BI	Commander over radio
I	O	Commander over radio
I	M	Commander over radio
I	BI	Commander over radio
B	O	radio
B	M	radio
B	BI	Commander over radio (then radio)
C	O	radio
C	M	radio
C	BI	Commander over radio

Pressel ON

4 way switch	3 way switch	Crew hears
A	O	radio
A	M	radio
A	BI	radio
I	O	Commander only
I	M	Commander only
I	BI	Commander only
B	O	radio
B	M	radio
B	BI	radio
C	O	radio
C	M	radio
C	BI	radio

For a full understanding of how the Larkspur harness systems work the user should refer to the user handbooks W.O. Code No. 11347 and 11195. This document is only concerned with the changes brought about by the Larkspur II upgrade.

Note: Microphones, magnetic, SI No.1A and No.6 can still be attached to any 6 point socket on A or B vehicles except for that on the JD8. The Microphones, magnetic, SI No.4 and No.7 for B vehicles CANNOT be attached to the 12 point socket on the RSB2 labelled COMMANDER, only the commander's personal unit or Microphones, magnetic, SI No.3 and No.5 can be attached to this socket.

CAUTION: Attaching a Larkspur II crewman's personal unit to a Larkspur installation not modified to Larkspur II will connect the monitor earphone to the Voltage Control Relay line if the monitor function is selected.

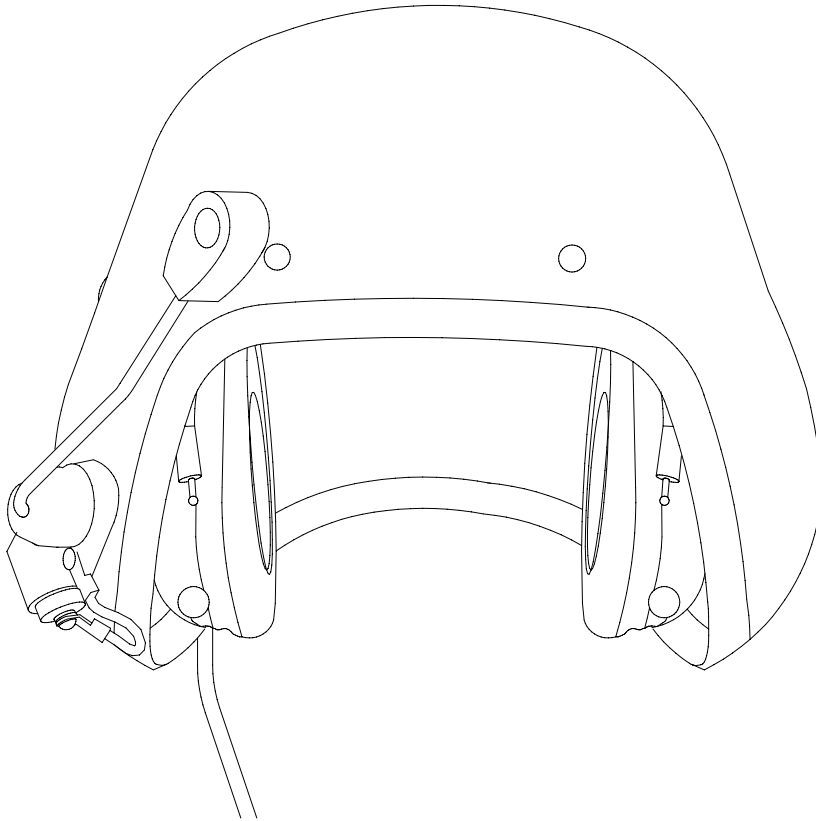

Fig. 1 Helmet, Headset electrical

2. A vehicle installation

There is no outward difference between Larkspur and Larkspur II installations. Inspection of the modification record plate of the JD9 will show the figure 2 to have been struck off if it has been upgraded to the Larkspur II standard.

The commander's personal unit allows the commander to select up to 3 radios or the intercom by use of a 4 position switch on the front of the unit. A pressel button is mounted on the top face of the unit in front of the sealing plug. A 3 position switch located on the bottom face of the unit controls the monitor and battle intercom functions of the harness:

Off

Monitor

Battle Intercom and Monitor

The crewman's personal unit also has a 4 position switch on the front face. This controls the monitor and live intercom functions:

Monitor

Live intercom and Monitor

Off

Live intercom

A pressel button is mounted on the top face of the unit in front of the sealing plug. There is also a rotary gain control on the bottom face of the unit to control the monitor gain. Therefore, in order to control the gain of the radio or intercom the gain control on the CU31 box or JD8 box is adjusted. But if the monitor function of the headset is used the gain control on the personal unit is used additionally.

The monitor facility provided to each crew member depends upon their connection to the JD9. The driver is only supplied with the intercom line such that switching the monitor facility on merely provides him with a separate gain control for each ear rather than a single gain control for both ears. The loader/operator can monitor the A radio or the B radio depending upon the commanders 4 position switch settings. The gunner can monitor the B radio.

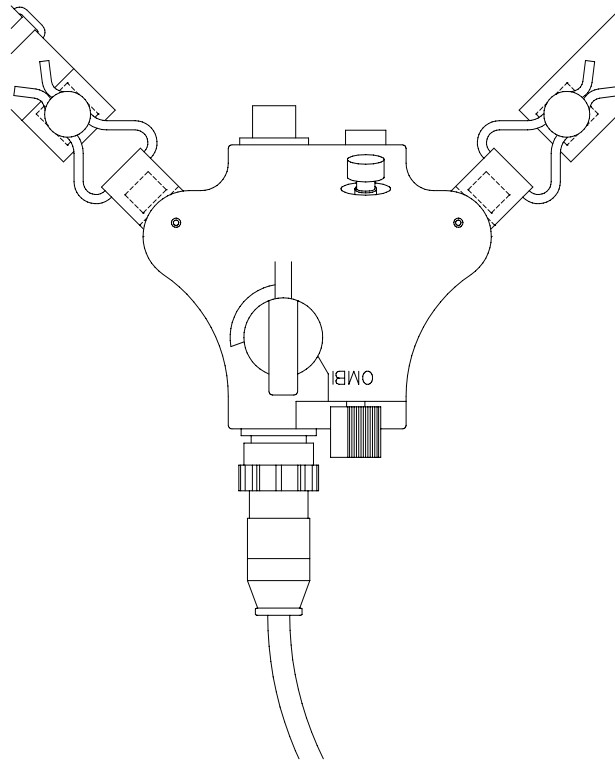

Fig. 2 Commander's personal unit

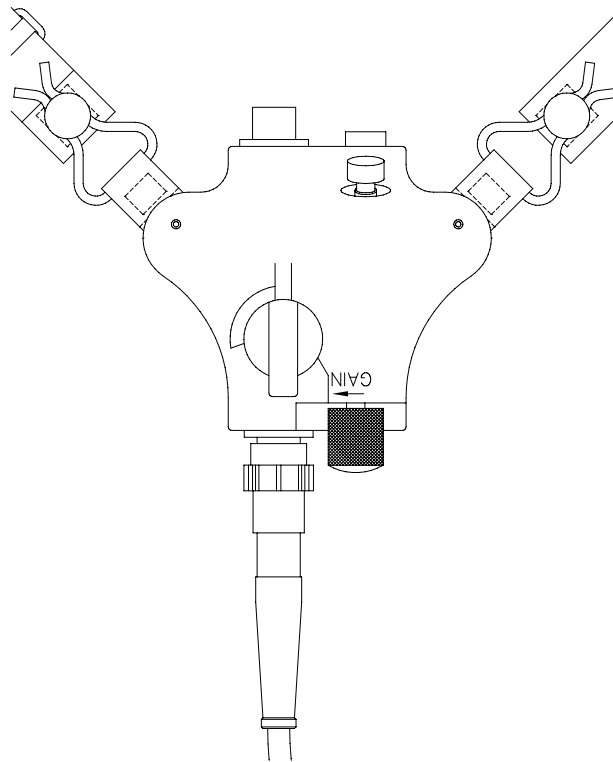

Fig. 3 Crewman's personal unit

3. B vehicle installation

As the J2 box is replaced by the RSB2 box to upgrade the harness of a B vehicle it should be immediately apparent whether the harness being used is Larkspur or Larkspur II.

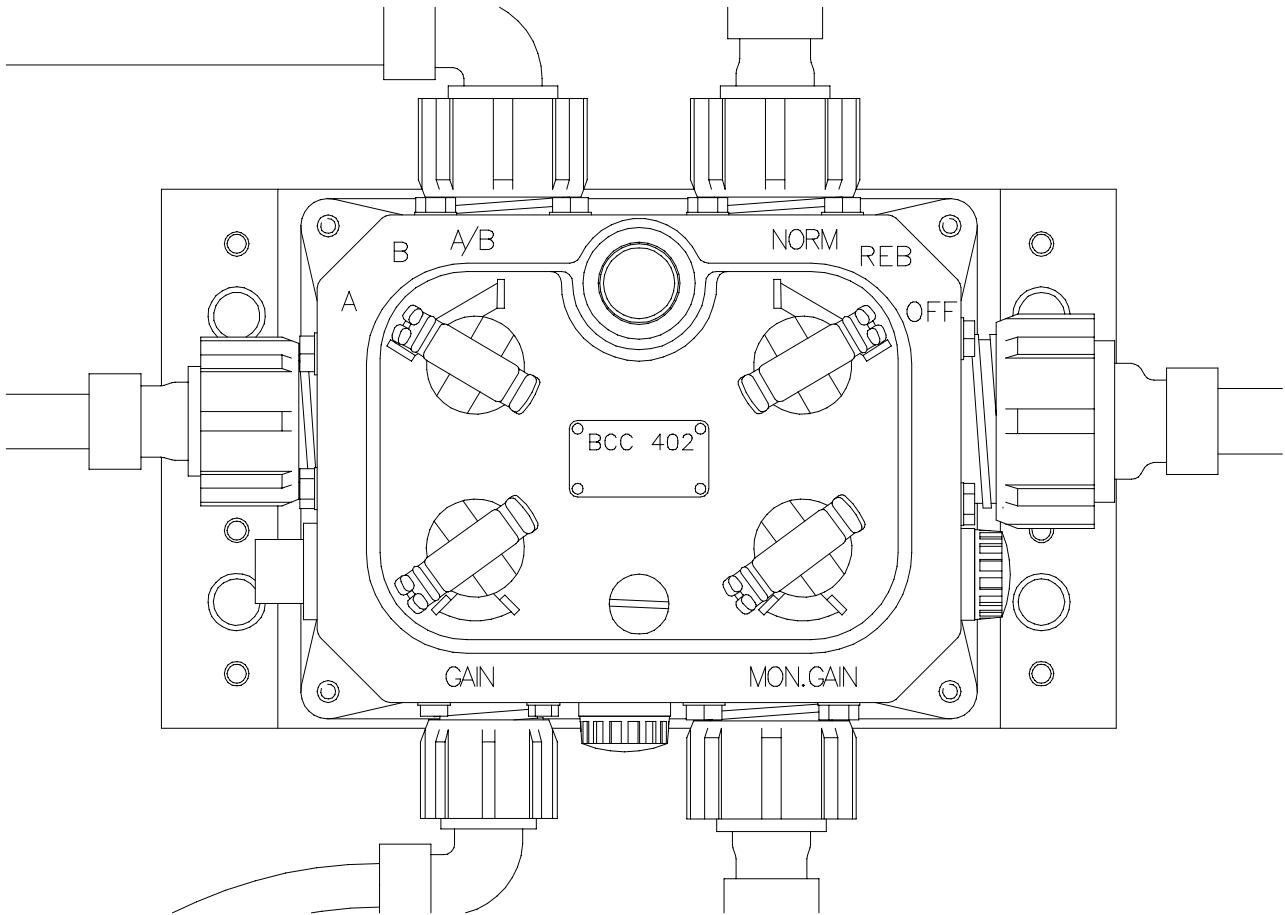

Fig. 4 RSB2

The commander's and crewman's personal units used for the B vehicle harness are identical to those used for the A harness. If the commander of a B vehicle selects the C radio using his front mounted 4 position switch the harness simply provides access to the B radio.

The monitor facility provided for B vehicles is simpler than for A vehicles. The commander chooses which radio to monitor using the switch on the RSB2 and the radio the crew monitor is set accordingly. When the switch is set to A the commander monitors the A radio and the crew monitor the B radio and vice versa. When the switch is set to A/B the commander and crew monitor both A and B radios.

Chapter 2 - Using the Harnesses

4. Preparation

No special preparation beyond that already called for in the use of Larkspur harness systems is required.

5. Operation

A) A harness

The operation of the A harness in Larkspur II differs from that of Larkspur only as already mentioned above.

B) B harness

The operation of the B harness in larkspur II differs from that of larkspur in the following ways:

- i) The RSB2 box has a combined OFF/REB/NORM switch in place of the 2 separate switches on the J2.
- ii) The RSB2 box has 2 gain controls: GAIN and MON. GAIN, which are not to be found on the J2, that control the gain for the commander's personal unit attached to the 12 point socket on the bottom face of the RSB2.
- iii) The RSB2 box has a socket labelled ALT PSL which allows connection to be made to a foot pressel.
- iv) The RSB2 is only available as a 28 volt item.

The only other differences in the operation of the B harness are those already mentioned above.

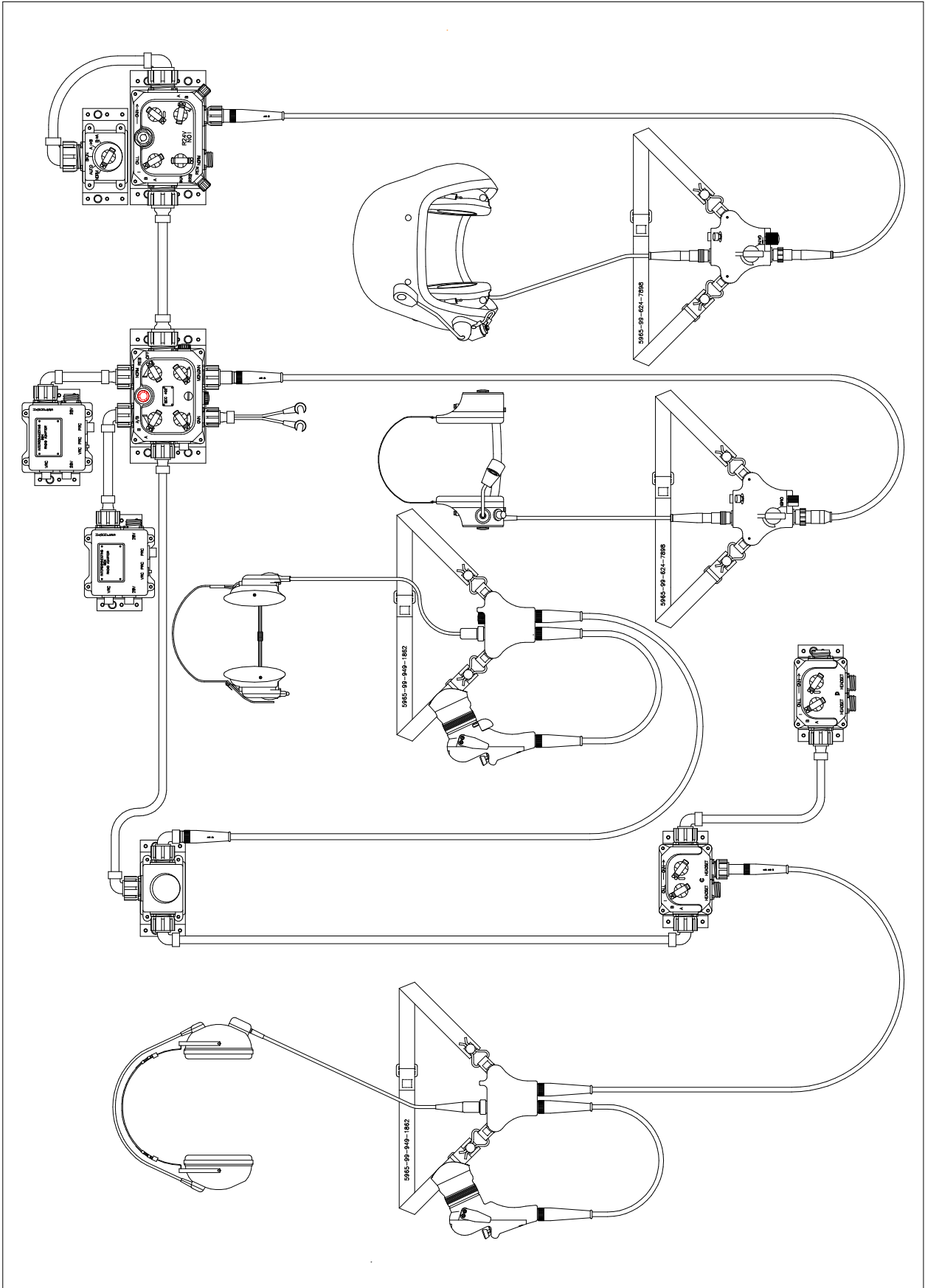

Fig. 5 Example B harness

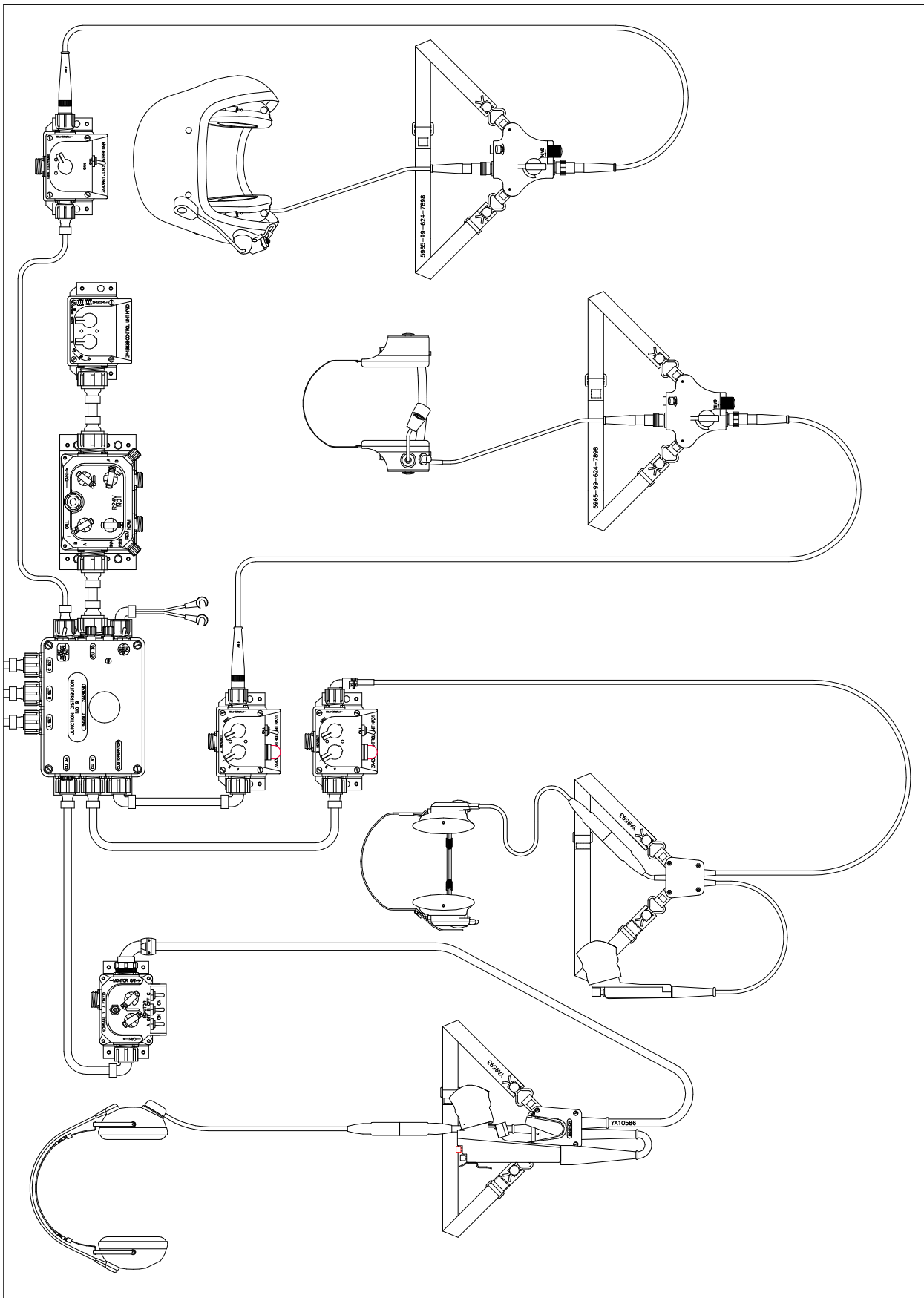

Fig. 6 Example A harness

List of items introduced into service by Larkspur II:

Larkspur II items

Commander's personal unit	5820 99 117 4349
Crewman's personal unit	5820 99 117 4348
Cable, Commander's	5995 99 620 8061
Cable, Crewman's	5995 99 620 8059

RSB2

Larkspur II / Clansman items

Helmet, headset electrical, A vehicle	5965 99 620 3251
Headset microphone A vehicle staff user	5965 99 620 5668
Headset microphone B vehicle & infantry	5965 99 620 8320

List of items modified to Larkspur II standards:

JD8	Mod 1	ZA43841
JD9 24V	Mod 2	ZA43836
CU31	Mod 2	ZA43839
CU34 Mk.1/1	Mod 1	ZA54105
CU34 Mk.2	Mod 1	5820 99 949 0986

6. Bibliography

Electrical and Mechanical Engineering Regulations, Telecommunications C702, Microphone Assemblies, Technical Handbook, Technical Description, June 1966

Electrical and Mechanical Engineering Regulations, Telecommunications C712, Receiver Assemblies, Technical Handbook, Technical Description, June 1966

Electrical and Mechanical Engineering Regulations, Telecommunications C722, Microphone And Combined Receiver Assemblies, Technical Handbook, Technical Description, September 1979

Electrical and Mechanical Engineering Regulations, Telecommunications L772, Part 1, Radio Control Harness Type A, Technical Handbook, Technical Description, August 1973

Electrical and Mechanical Engineering Regulations, Telecommunications L772, Part 2, Radio Control Harness Type A, Technical Handbook, Fault Finding And Repair, August 1973

Electrical and Mechanical Engineering Regulations, Telecommunications L777, Wireless Harness Type A, Technical Handbook, Modification Instruction No.s 5, 6, 7 & 8, February 1975

Electrical and Mechanical Engineering Regulations, Telecommunications L779, Wireless Harness Type A, Technical Handbook, Miscellaneous Instruction No.7, December 1972

Electrical and Mechanical Engineering Regulations, Telecommunications L782, Part 1, Radio Control Harness Type B, Technical Handbook, Technical Description, August 1973

Electrical and Mechanical Engineering Regulations, Telecommunications L782, Part 2, Radio Control Harness Type B, Technical Handbook, Fault Finding And Repair, August 1973

Electrical and Mechanical Engineering Regulations, Telecommunications L789, Wireless Harness Type B, Technical Handbook, Miscellaneous Instruction No. 12, December 1972

LARKSPUR II AUDIO CABLE PIN OUTS

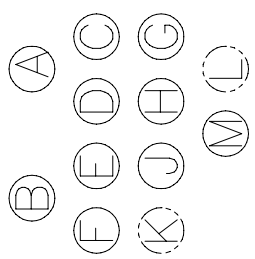
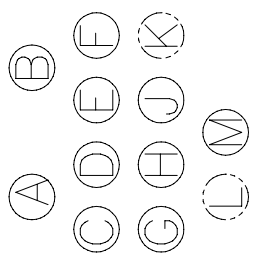
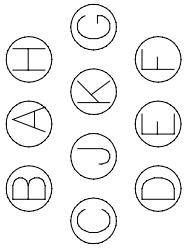
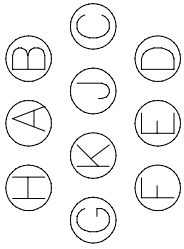
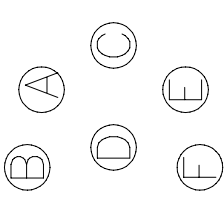
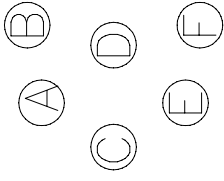
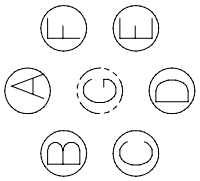
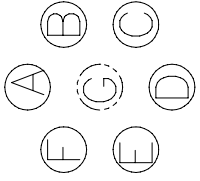
<p>(5995 99 620 8061)</p> <p>A) Mic [G] B) Earth [E] C) Select A [J] D) Pressel [H] E) Monitor Relay [C] F) +28v [F] G) Earth [K] H) Select B [A] J) Monitor Gain [D] K) N/A L) N/A M) Working Gain [B]</p>  <p>MEDIUM-12, 104 PLUG FACE</p>	<p>(5995 99 620 8061)</p> <p>A) Mic [G] B) Earth [E] C) Select A [J] D) Pressel [H] E) Monitor Relay [C] F) +28v [F] G) Earth [K] H) Select B [A] J) Monitor Gain [D] K) N/A L) N/A M) Working Gain [B]</p>  <p>MEDIUM-12, 104 VIEW ON PLUG SOLDER BUCKETS</p>	 <p>12-10 105 SOCKET FACE</p>  <p>12-10 105 VIEW ON SOCKET SOLDER BUCKETS</p>
 <p>SMALL-6, 104 PLUG FACE</p>	<p>(5995 99 620 8059)</p> <p>A) Mic [A] B) Earth [B] C) Pressel [C] D) Earth [D] E) Monitor Gain [E] F) Working Phone [F] G) N/A</p>  <p>SMALL-6, 104 VIEW ON PLUG SOLDER BUCKETS</p>	 <p>10-7 105 SOCKET FACE</p>  <p>10-7 105 VIEW ON SOCKET SOLDER BUCKETS</p>