



WS No. 19 Mark III

**This file has been down loaded from
The Wireless-Set-No19 WEB site.**

**All files from this WEB site are free of charge.
If you have been charged for this file then please
contact the person you obtained it from as he/she
has illegally obtained both the file and money they have
charged you.....**

COPY OF WAR DIARY

7th Armoured Brigade Signal Squadron

January, April and May 1942

Context

At the end of 1941, after Japan entered the war and the situation in the Far East had deteriorated, 7th Armoured Brigade was ordered to Burma from the Middle East, where it had distinguished itself against the Italians in the desert. The Brigade comprised the 7th Hussars and 2nd Royal Tank Regiment, equipped with American M3 light tanks, 1st Battalion West Yorkshire Regiment, 414 Battery RHA, 95 Anti-Tank Battery RA, 65 Company RASC and of course its Brigade Signal Squadron which provided the communications for its headquarters and down to its units.

There were insufficient troops in Burma, and they were inexperienced, 17th Indian Division and 1st Burma Division having been rather hastily assembled to meet the Japanese threat. 7th Armoured Brigade reached Rangoon by late February 1942: They were immediately deployed and were quick to prove their worth as the only battle-hardened and well-equipped formation in Burma. Although by the time they arrived it was clear that Burma would eventually be lost, the brigade's contribution to the orderly withdrawal to India was immense. It has to be remembered that the two divisions had only the most rudimentary wireless communications, as did the headquarters of 1st Burma Corps ("Burcorps") formed in March 1942 for the tactical control of the Force. At times the links provided by the signal squadron were the only means by which the then Lt Gen Slim was able to communicate with his divisional commanders.

The diary for February and March is missing (though the brigade was embarked for most of February). Similarly there is no diary for the latter half of 1942 while the brigade was refitting in India and eventually moving to Iraq. Originally each month's diary formed a separate document, which explains why there are Annexes A to E for April and Annexes A & B for May.

WAR DIARY

OR

7. Armoured Bde Sig Sqn

Army

Instructions regarding War Diaries and Intelligence

Summaries are contained in F. S. Regs., Vol. 1.

Title pages will be prepared in manuscript.

INTELLIGENCE SUMMARY.

(Erase headings not required.)

Hour, Date, Place.	Summary of Events and Information.	Remarks and references
1942.		
1st January.	<p>Location:- Barracks Abbassia, CAIRO.</p> <p>OC visited GHQ ME today to discuss establishment of personnel with DAAG (Major Whitbread). We are being kept rigidly to our War Establishment for our new role. OC (Capt. Felton) experiences trouble returning from Cairo at night - broken half-shaft.</p>	
2nd January.	<p>Location:- Unchanged.</p> <p>Main endeavours concentrated on re-equipping Squadron in shortest time possible. OC to GHQ ME re issue vouchers and stores, and transport twice during day.</p>	
3rd January.	<p>Location:- Unchanged.</p> <p>7th Armoured Div. Signals are back at Mena Camp today. CO (Lt.Col.Crawford MBE) visits us.</p> <p>2 4/5 kw charging engines are collected from Tura Caves (BOD) in afternoon. We (7th Armoured Brigade complete) are ready to move out to Beni Yusef Camp tomorrow morning, but at 2100 hours orders for move are cancelled by Staff Captain.</p>	
4th January.	<p>Location:- Unchanged.</p> <p>Visited by Capt. Hood (Sigs SO AFV's) and Lt.Qmr. Boon (7th A.D.Sigs) during morning, both of whom are going to give a helping hand in our re-equipping. Lt. Boon on job of chasing Ordnance Stores through different mazes of Ordnance hideouts is definitely an asset.</p> <p>Informed by Capt. Hood that our allowance of accumulators for Regimental Troops is to be 45 plus ME "Desert" increment of 79 - totalling 124 per troop - quite adequate!</p>	
5th January.	<p>Location:- Unchanged.</p> <p>40 O.R.'s who were left behind in Libya with Div Sigs have been returned to us today. They are all dug for leave but as we expect to move to new location in a day or so they will have to wait for a few days.</p> <p>Received 7th A.B. Movement Order No.3 - we move to Quassassim Camp tomorrow. Train and road parties arranged for move. Party returns with 6 3-ton lorries drawn from Alexandria.</p>	

4/11/42
2340.

Rm
18/19

WAR DIARY

Army

OR

INTELLIGENCE SUMMARY.

(Erase headings not required,)

Instructions regarding War Diaries and Intelligence
Summaries are contained in F. S. Regs., Vol. I.
Title pages will be prepared in manuscript.

Hour, Date, Place. 1942.	Summary of Events and Information.	Remarks and referenc
<p>Locations:- Moving to Quassassin Camp. 6th January.</p>	<p>Train Party Depart - 0800 hours. Road Party Depart - 1000 " Former under command 2/Lt. Squier and latter under Capt. Felton. On arrival new location we settle into Camp 41 EC Tahag - we are now in a tested Camp. Luxury for some of us. Party despatched to Alexandria to draw more vehicles. 3 15-cwt trucks and 9 motor cycles.</p>	
<p>Location:- Camp No.41 EC Tahag. 7th January.</p>	<p>We are informed that Div Commander will visit Brigade on 10th January. Party which returned from Div Sigs on 5th January are sent on leave to Cairo.</p>	
<p>Location:- Unchanged. 8th January.</p>	<p>Party despatched to Alexandria on 6th January return with 3 15-cwt trucks and 9 motor cycles all brand new! They will all need careful running-in. We are informed that our present adjutant Capt. A.C.Cox R. Sigs is to be promoted and appointed to command this Squadron vice our late commander Major Stetham.</p>	
<p>Location:- Unchanged. 9th January.</p>	<p>Capt. Felton to Cairo to visit Adjutant and to perform several errands at GHQ. Issued vehicles to Regimental Troops from those drawn at Alexandria. Informed, Div. Commander now not visiting us tomorrow - DAQMG coming instead. Informed on Capt. Felton's return that SO in C MEF is to visit Squadron next Thursday 15th January. Major Cox comes to take over command on 13th.</p>	
<p>Location:- Unchanged. 10th January.</p>	<p>We are asked to forward a vehicle state to Brigade HQ - apparently shipping people are to work on basis of complete establishment only. We have more vehicles than our establishment, but as they are considered necessary we have asked Div Sigs to help persuade ME to grant us extra. SQMS obtains large load of stores today. AGV returns from Ordnance newly painted, looking more than ever like "things to come".</p>	
<p>Locations:- Unchanged. 12th January.</p>	<p>Col. Anstice D.S.O. has now taken over command of Brigade and is appointed Brigadier. One of the new No.19 Sets issued to each of Regimental Troops. After repeated applications by us for adequate phone communication in the camp great</p>	

WAR DIARY

OR

INTELLIGENCE SUMMARY.

Instructions regarding War Diaries and Intelligence
Summaries are contained in F. S. Regs., Vol. I.
Title pages will be prepared in manuscript.

(Erase heading not required.)

Hour, Date, Place. 1942.	Summary of Events and Information.	Remarks and ref.
<p>Locations:- Unchanged. 13th January.</p>	<p>CO (Col. Crawford) arrives after lunch, accompanied by new OC, Major Cox. Practice inspection held for SO in C's visit. Major Cox takes over Squadron. OC visits Sub-Area Sigs re 'phone communication.</p>	
<p>Locations:- Unchanged. 14th January.</p>	<p>Phone laid by Sub Area to 7th Hussars. Brigadier asked for exchange within Brigade HQ. OC promises OK as soon as Signal Office truck completed.</p>	
<p>Locations:- Unchanged. 15th January.</p>	<p>Squadron visited and inspected by Major General Penny SO in C MEF. The SO in C was very pleased with what he saw. He made a short speech thanking everyone for their work in the past and wishing us well in future. Signal Office truck completed and taken into immediate use to provide exchange for various phoges in Brigae HQ. Training and fitting of vehicles in full swing. The internal communication of M3 (Honey) tank exciting comment. In tanks with No.11 sets we have fitted an I.C. System conceived and built locally. It is not showing up too well under tests and the material is poor. We are all very much concerned over above, and all heads are being put together to find an alternative. OC reports matter to CO & ME.</p>	
<p>Locations:- Unchanged. 16th January.</p>	<p>OC to Cairo to clear up outstanding items of stores. Capt. Hood visits Brigade HQ. He warns us that certain number of tanks would not have fishing-rod type aerals issued and that ordinary rod would cause difficulties re traverse of turret. We must find way out of this one. He also assures us that IC of M3 with No.11 sets have been thoroughly tested and found OK - sceptical! Query by Brigadier re ammeter shortage in sets of Regiments as 2 RTR report they have not got enough. Capt. Felton phoges OC at ME re this matter, and asks him to press matter at ME. OC gives instructions, during above conversation, for the drawing of several vehicles and quantity of stores, also NCO's on courses at MAADI, are to be brought back to Squadron immediately. Instructions from Bde re issue of KD clothing & scale of tentage. Very strong wind in evening works up into dust storm. Several tents blown down & nearly everyone rather uncomfortable during night.</p>	

WAR DIARY

OR

INTELLIGENCE SUMMARY.

(Erase heading not required.)

Army

Instructions regarding War Diaries and Intelligence
Summaries are contained in F. S. Regs., Vol. I.
Title pages will be prepared in manuscript.

Hour, Date, Place. 1942.	Summary of Events and Information.	Remarks and refer
<p>Locations:- Unchanged. 17th January.</p>	<p>SO's from Regiments brought in to see OC who clears up several points with them including that of the ammeter. OC phones QM at Mena asking that KD clothing be drawn there for us. SQMS sent to Cairo to collect outstanding stores and indents - also takes one of No.19 sets in to Ordnance for repairs. We are already having trouble with these sets. They heat up considerably after few hours work and eventually condensers in various sets begin to go 'dis' one after the other. Foreman of Signals very gloomy about their performance. Training on No.19 sets to be intensified in case our operators are at fault? Vehicle party is to move on 20/21 January!! Fitting and adjustments to vehicles and equipment well on way to completion now - Foreman very pleased with his new charging lorry and engine.</p>	
<p>Locations:- Unchanged. 18th January.</p>	<p>Sunday Service at 0900 hrs. Training commences at 1000 hrs continuing for day as normal. Training frequencies received from Area Sigs & re-allocated to Regiments. Signal received from MidEast stating that this Squadron now under command HQ 7 Armd. Bde. OC visits No.2 General Hospital Tahag to query return of personnel of Squadron "there in". SQMS in Cairo drawing more stores and getting ACV tended to (Broken spring).</p>	
<p>Locations:- Unchanged. 19th January.</p>	<p>Training and issuing of kit to personnel. Some more stores drawn up.</p>	
<p>Locations:- Unchanged. 20th January.</p>	<p>Clothing issue today to all personnel (KD). We are told that accumulators outstanding for us are being initially charged and will be available tomorrow afternoon. NCO i/c MT arrives back with 4 Breadvans (15cwt W/T vans). They need fair amount of fitting etc. ACV returns from Ordnance - F of S and staff start work of fitting sets etc immediately. Time is getting short now as vehicles should be moving off (destination unknown) tomorrow. Train party to go approximately 26/27 January.</p>	

Instructions regarding War Diaries and Intelligence
Summaries are contained in F. S. Regs., Vol. I.
Title pages will be prepared in manuscript.

WAR DIARY

OR

INTELLIGENCE SUMMARY.

(Erase heading not required.)

Hour, Date, Place. 1942.	Summary of Events and Information.	Remarks and refer
<p>Location:- Unchanged. 21st January.</p>	<p>SQMS Marks obtains balance of accumulators & stores outstanding with exception of few controlled items. Bde orders issued re move of road party (with Bde Tpt) to Suez prior to embarkation. Capt. Felton detailed by OC to be i/c Road party - they leave first light tomorrow. Everybody works at high pitch throughout day to get everything ready as all our equipment & stores are going on the vehicles of the road party. By evening last minute jobs completed & last of stores etc to be obtained from ME for long time (we think) loaded up. Personnel of road party inspected by OC & everybody given detailed instructions. We have orders that road party should move off in KD uniform - this means some hardship for men as the weather at the moment is very cold for Egypt. After several representations to higher authority orders re KD clothing cancelled and we are being allowed to retain winter clothing for road party until they actually "embark". This order received at 2200 hrs meant a lot of hurried readjustments.</p>	
<p>Location:- Unchanged. 22nd January.</p>	<p>Road party with whole of Squadron's MT and stores moved off at 0615 hrs in good order under Capt. Felton (OC "O" Tpt), with many urgent requests from various people to take great care of our new and precious equipment. The Squadron as a whole has worked extremely hard to get equipped in the time given and having achieved this object everybody is naturally keen on taking care of their respective gear. With departure of road party, remainder of Squadron with OC & Lt Squier will go by train on or about 26/27 January. We had to stick very closely to WE with our vehicles for road party and therefore we have 3 vehicles (15-cwts) left which will eventually be handed over to No.1 Squadron before we go. Air-raid Warning RED received at 1230 hrs (unheard of!). Nothing transpired - all clear 1330 hrs.</p>	
<p>Location:- Unchanged. 23rd January.</p>	<p>OC departs for Cairo on 24 hr leave - first he has had for considerable time. F of S arrived in during evening. He had been sent down from Vehicle Party by Capt. Felton in one of our Ford 8-cwts to No.5 BOD to get urgent MT spares. Unfortunately near the end of his journey at Quassassin his truck was involved in an accident - another truck ran into him - which has completely written off our vehicle. Lt. Squier phoned Div Sigs now at ABBASSIA in endeavour to contact OC</p>	
<p>M.P. & M.B.W. 3171G 6374841-1,00,000</p>	<p>Pad now of course Squadron will be one truck short on embarkation. OC contacted & replacement arranged.</p>	

Instructions regarding War Diaries and Intelligence
Summaries are contained in F. S. Regs., Vol. I.
Title pages will be prepared in manuscript.

WAR DIARY

OR

INTELLIGENCE SUMMARY.

(Erase heading not required.)

Hour, Date, Place.	Summary of Events and Information.	Remarks and refer
1942.		
Location:- Unchanged. 24th January.	F of S despatched to 5 BOD to obtain spares required by OC Road party & later returned to Suez in replacement truck. Squadron parades as for marching out as train party. Transport for conveyance of personnel to Railhead laid on.	
Location:- Unchanged. 25th January.	OC returned from leave early morning. OC held enquiry into traffic accident of Friday & after phone conversation with APM Moascar everything is fixed up & all traffic accident reports etc completed. We move by train to Suez tomorrow eveing 2000 hrs.	
Location:- Unchanged. 26th January.	SDR required for Suez - tried to supply one from remaining "Hulks" but "considered opinion" decided none of them would make it, so Brigade HQ got a DR from XXXX 6 RTR. Lt. Col. Crawford MBE visited Squadron during morning and said goodbye to everyone - We shall be very sorry to break off our association with 7th Armoured Division as quite obviously we have done much campaigning in the Western Desert with under their parental leadership. Remainder of Train Baggage packed and stacked ready for conveying to train at El Ba'alwa Station. 1700 hrs Baggage lorries loaded and despatched to train. 1900 hrs remainder personnel conveyed to train. 2000 hrs all aboard train and settled down for long night journey.	
Location:- Moving to Port of Embarkation (Suez). 27th January.	0700 hrs - detrained - cup of tea for all ranks. Baggage loaded and conveyed to quayside by lorry - personnel march. Great speculation by all ranks on type & shape of our ship! Bodies and baggage transferred aboard by lighter by 1100 hrs - ship is HMT Ascanius. Food produced for everyone by 1130 hrs. Usual bustle and scurry of settling down into a "trooper" ensued - arms handed in, money changed etc etc, keeping everyone busy for remainder of day.	
Location:- HMT Ascanius. 28th January.	0200 hrs "Anchors away" few of us realizes this until dawn. Ship as usual rather overcrowded. Whole day spent in organising accomodation & settling in.	

WAR DIARY

OR

INTELLIGENCE SUMMARY.

Instructions regarding War Diaries and Intelligence
Summaries are contained in F. S. Regs., Vol. I.
Title pages will be prepared in manuscript.

(Erase heading not required.)

Hour, Date, Place.	Summary of Events and Information.	Remarks and refer
1942.		
<p>Location:- HMT Ascanius - Red Sea. 29th January.</p>	<p>Organising training and PT. Difficult job this as Ascanius no luxury liner & therefore accomodation for such endeavours scanty. OC Ship holds conference re above. OC buttonholes O i/c OFF re spares for our No.19 sets. Is alarmed to find that OFF is holding 30 spares for No.19's at all. Checked and rechecked through OFF stores receipt vouchers and unable to trace any spares of this nature. This is a complete letdown for us as we were assured by AFV's that our OFF would be stocked with every thing concerning a No.19 set that Ordnance could lay hands on. This means a serious risk as far as No.19 sets are concerned because they have already shewn signs of burning out the odd condenser & resistance etc and if no supplies are available at our destination we shall be in dire straits. BM consulted and decision is made to cable ME from first port of call.</p>	
<p>Location:- HMT Ascanius. 30th January.</p>	<p>Training programme produced to cover next two weeks - plenty of morse & no.19 set training is "Motif". Hesitate to take very definite action re procedure as the authorities at our unknown destination will most probably have ideas of their own which they may want us to adopt. In any case the majority of the Brigade have seen so many changes & types of procedure that they can quite easily cope with anything new very quickly.</p>	
<p>Location:- Unchanged. 31st January.</p>	<p>Training. Innoculation & Vaccination being prepared.</p>	

1st April 1942

Original

orig 31 St. Kay

Army

3044

7 Arm. Bde

Instructions regarding War Diaries and Intelligence
Summaries are contained in F. S. Regs., Vol. I.
Title pages will be prepared in manuscript.

WAR DIARY

OR

INTELLIGENCE SUMMARY.

(Erase heading not required.)

Hour, Date, Place 1942.	Summary of Events and Information	Remarks and references
<p>1st April.</p> <p>3349</p> <p>1600 hrs.</p> <p>1700 hrs.</p> <p>Approx Midnight.</p> <p><i>(See return to 2nd Echelon)</i> <i>Shamal</i></p> <p><i>(at 7.00)</i></p>	<p>Reports of enemy now advancing on Prome. 17 Div intend to make a stand around the town. Foreman of Signals in residence at Brigade HQ continues repair & maintenance. Brigade commander hold conference re cutting down soft vehicles in the fighting echelons. Those not required are to proceed N to ALLANMAYO with B Ech, today. OC & 2 i/c in conference decide we can manage with one soft vehicle only, an IM's and charging track. This will need either another 1260 watt engine or several chore horses for charging. OC 414 Bty again comes to our rescue and offers us one of his charging engines. BTO (Maj. Fleming) says we can have an armoured car scrounged by his boys if we produce a 15 cwt truck in lieu. This is our golden opportunity for an IM's truck but the replacement required offers difficulties. Luckily the Staff Captain steps in and offers OC a salvaged truck from Brigade Reserve. Our luck is obviously in.</p> <p>Armoured car (which is open American type ideal for our purpose) taken over by 2/Lt Squier at B Ech on oath that truck in lieu is eventually forthcoming. Armoured car despatched to A Ech where F of S & Cpl Read fit it up with a 550 watt (ex 414 Bty) & 2 chore horse engines for charging, batteries and necessary tools. We are also carrying some batteries on Brigade HQ's 'slave carrier'. <i>usual</i></p> <p>F of S reports work on sets now complete (together with his issued sweet comment on the No. 19 set).</p> <p>17 Div tell us to open up on their link Capt Felton deals with this on phone and it is decided to keep contact with our breadvan which is with them on the forward control. This enables us to put our B Ech link onto 2nd No. 9 set in ACV. There is some interference between sets but since we are unable to eradicate this without changing forward control frequency we decide to put up with the noise.</p> <p>All soft vehicles depart under Capt. Hough, Brigade's HQ Squadron leader, to join B Ech in their march N. Brigade HQ now all armoured except for cookhouse, ambulances and DRs.</p> <p>We are dug out of bed and told to get ready to move as enemy have broken through at Prome and 17 Div are being heavily attacked on all sides. Communications all OK. We move down towards road junction where 7 Hussars and 1 West Yorks take up positions along main road to prevent any enemy threat.</p>	

WAR DIARY

Army

Instructions regarding War Diaries and Intelligence

Summaries are contained in F. S. Regs., Vol. I.

Title pages will be prepared in manuscript.

OR
INTELLIGENCE SUMMARY.

(Erase heading not required.)

Hour, Date, Place 1942.	Summary of Events and Information	Remarks and references
2nd April.	<p>Brigade HQ standing by to move at first light from road junction TAMAGAUK N to Allannayo. Owing to 10 miles of forest on first lap everyone on "qui vive" for road block, but after leaving at 0700 hours Brigade arrive without incident in Allannayo area at 0930 hours. 2 RTR have remained behind under command 17 Div. We now come directly under command BUR CORPS. Brigade HQ established in midst of market garden pleasant prospect from both comfort and diet angles. Communications to all Units OK. Breadvan detachment despatched to Allannayo to report to CSO BUR CORPS to act as link to us. Receiving 17 Div and 2 RTR R9/7 on forward control. During morning Brigadier talks to 17 Ind Div commander who is still in Frome. Apparently situation round Frome not too good and 17 Div are going to retire if possible.</p>	
3rd April.	<p>17 Ind Div have retired from Frome, aided by 2 RTR who ferried most of them away on tanks. OC visits Corps HQ to discuss communications with CSO also visits our W/T detachment whilst there. Brigadier holds conference - we are to move back some 40 miles to area SETHWA today. Brigade commander tells OC he can withdraw W/T detachment from Corps. Capt Felton sent to do this. Brigade moves back as follows : B Ech 1600 hrs HQ & Squadron 7 Hussars 1800 hrs Brigade HQ 2000 hrs Squadron 7 Hussars 2030 hrs. Arrive new area 2330 hrs. Close leaguer for night along side of road. Communications all OK. 2 RTR remain under Bur Div at Allannayo OC arranges with them to have a link at Bur Div working to HQ 2 RTR on our forward control frequency so that we may hear of any "flap". This works quite well.</p>	
4th April.	<p>Broke leaguer at dawn and moved into new area, a village $\frac{1}{2}$ mile off road. We will apparently be here a little while, and as units of Brigade are all quite close we will lay lines. 2 RTR still under command Bur Div so we leave a set open to them during daytime to "keep in the picture". They are 45 miles away and speech is R9 each way. Signal Office and line detachment are in Brigade HQ and line parties get cracking. All lines laid in $1\frac{1}{2}$ hours. Corps Signals representative arrives and promises a line today from them along via main route along road. Slight mishap over this line as a party of Indians arrive and lay it to West Yorks who accept it with signs of bewilderment. Sgt. Harris NCO i/c Signal Office eventually discovers mistake and rectifies it. Speech on this line quite good. Informed by Brigadier that 48 Inf Bde are now under our command.</p>	

Instructions regarding War Diaries and Intelligence
Summaries are contained in F. S. Regs., Vol. I.
Title pages will be prepared in manuscript.

WAR DIARY

OR

INTELLIGENCE SUMMARY.

(Erase heading not required,)

Hour, Date, Place 1942.	Summary of Events and Information	Remarks and references
5th April.	<p>Brigade HQ sitting tight doing nothing except maintenance and ordinary routine. Capt Felton despatched with SSM to MAYMYO on various errands. Mainly to get necessary odds and ends for chaps. Is going to try and scrounge some testing instruments from the CSO whilst there. OC with Brigadier and BM visits Corps HQ. Corps commander visits us for conference. 48 Bde now no longer under our command. Communications all line except for watch on forward control for 2 RTR.</p>	
6th April.	<p>Corps line giving trouble - send line party off to do their best as nothing seems to be happening at Corps end. On arrival at corps they find several bays down through bombing. Line repaired and communications OK. 48 Bde also tee'd in on this line. Very poor speech - send our line party down to find out why and they discover that Indian linesmen have connected up their instrument incorrectly. This was rectified by Brigadier Parker after some argument. Corps commander & GGS (just out from home) visit us during evening. 2 RTR told to remain open until 2100 hours tonight. They fade out at 2030 hours and after calling them repeatedly on rod and horizontal aerials we eventually hear them again at 2055 hours giving N and closing down signal. This is definitely bad practice and will be dealt with by OC when they come back to us again.</p>	
<p>7th April. Location still SATHWA.</p> <p>1530 hrs.</p> <p>1700 hrs.</p>	<p>Communications as for 4-6 April. 2 RTR opened up again on WT at 0800 hours - 0900 hours speech R9 each way. They receive OC's comments on closing down last night whilst still out of communication with us.</p> <p>Brigadiers conference. We are to move back to KOKKOGWA, W of TAUNGDWINGE where road runs E & W and with 48 Ind Inf Bde we come under command 1 Bur Div to defend this area. Brigade HQ to move 1930 hrs.</p> <p>All WT links open up and lines reeled in, Close leaguer Kokkogwa area after uneventful march, 2 RTR will move into same area as rest of Brigade later tonight. Commu- to 2 RTR fades out from 1800 hours onwards. At a range of approx 40/45 miles with both units moving most of the time this is not surprising.</p>	

WAR DIARY

Army

Instructions regarding War Diaries and Intelligence

Summaries are contained in F. S. Regs., Vol. I.

Title pages will be prepared in manuscript.

OR
INTELLIGENCE SUMMARY.

(Erase heading not required.)

Hour, Date, Place 1942.	Summary of Events and Information	Remarks and references
<p>8th April.</p> <p>0730 hours.</p> <p>1230 hours.</p> <p>1400 hours.</p> <p>1630 hours.</p>	<p>Communication to 2RTR established again 0200 hours. (as they get nearer to our new position). Brigade moves into leaguer area at first light. Dispositions of units all close and around Brigade HQ except 2 RTR who ^{are} about 2 miles away. Line party sent out to recce and lay lines. Signal Office established.</p> <p>1230 hours. All lines laid. WT closed on forward control. As we are now under command Bur Div commander asks OC to arrange communication to them.</p> <p>1400 hours. OC leaves with breadvan for Bur Div HQ, some 40 miles away by the ford over the YIN CHAUNG.</p> <p>1630 hours. Communication to Div OK R9 each way speech. OC visits OC Signals first Bur Div and is surprised by their lack of personnel and equipment. Apparently any help from us in respect of our communication to them will be gratefully received. Communication to Bur Div at night is poor. Heavy atmospherics.</p>	
<p>9th April.</p> <p>Location still Kokkogwa.</p>	<p>Communication - WT open to Bur Div and B Ech only. LT to other units in Brigade. See diagram as at 0001 hours 9th April.</p> <p>Capt Felton returns from Maymyo and Mandalay bringing various delicacies (veg & fruits). He also had some success in procuring WT spares (condensers etc) and an even more valuable item, a badly needed equipment, to wit, an Avo minor. Received a tip from Brigade OME Capt Catesby that there are certain electrical goods to be had from the oil companies workshops at YENNANYAUNG. Arrange to send F of S on the scrounge.</p>	
<p>10th April.</p>	<p>Communication as for yesterday until 1700 hours. when we get orders to send B vehicles, ie Signal office etc, back to B Ech. Line party starts to reel in immediately. WT opened. WT detachment despatched to HQ 48 Bde arriving about 1730 hrs. This No.19 set gave some trouble so an IM was sent on motor cycle and rectified fault. Communication as per diagram dated 10th April. Enemy appear to be approaching this area now. 48 Bde have reported contact. We close leaguer for night on outskirts of our area.</p>	

WAR DIARY

Army

OR

INTELLIGENCE SUMMARY.

(Erase heading not required,)

Instructions regarding War Diaries and Intelligence
Summaries are contained in F. S. Regs., Vol. I.
Title pages will be prepared in manuscript.

Hour, Date, Place	Summary of Events and Information	Remarks and reference
1942.		
<p>11th April.</p> <p>Dusk.</p>	<p>First light we move back approx into original area. of Kokkogwa. Battle seems to be developing S to SE of us. 48 Bde engaged. Bde HQ & HQ 7 Hussars remain in same area throughout daylight. During afternoon communications arranged as per diagram of today's date to avoid traffic congestion on forward control.</p> <p>7 Hussars have had patrols out S all day and 2 RTR have been operating with 48 Bde. Communications OK but some complications may arise if 2 RTR & 7 Hussars do not receive their replenishment party tonight as neither have retained their charging equipment with their fighting mechelons. As we have only a 550 watt & a chore horse, we will have some difficulty in helping them out.</p> <p>Bde HQ & 7 Hussars less patrols move 5 miles E towards TAUNG DWINGE and close leaguer for night. 2 RTR shout for batteries. We are able to produce 4 banks and 414 Bty are again able to help people out of the cart, by handing over two chore horses for 2 RTR to use.</p>	
<p>12th April.</p> <p>Dusk.</p>	<p>Broke close leaguer at first light. Bde HQ & 7 Hussars & HQ Coy 1 W. Yorks moved into a nearby village under cover. Communications were OK throughout the night. Difficulties of maintaining touch with Bur Div overcome by producing a link set from B Ech under the able guidance of the 2 i/c. During the day we received a message from OC 17 Div Signals asking for a set to be sent to them so that they could keep in touch with us. Short of sending a tank to do the job this was impossible as all our spare detachments had been sent away to do that job for other formations. However Brigadier decides he does not want communication with 17 Div and an LO going there is told to tell them so. Operations continue against enemy throughout day. They have tried again to make a roadblock on our line of retreat (W of us) but 2 RTR have been able to deal with it. No replenishment again tonight. Battery situation in regiments is shaky but not critical.</p> <p>We all move out again into the open and close leaguer.</p>	

WAR DIARY

Army

OR

INTELLIGENCE SUMMARY.

(Erase heading not required.)

Instructions regarding War Diaries and Intelligence
Summaries are contained in F. S. Regs., Vol. I.
Title pages will be prepared in manuscript.

Hour, Date, Place 1942.	Summary of Events and Information	Remarks and references
<p>13th April. Dawn.</p> <p>approx. 1100 hrs. 1400 "</p> <p>1700 hrs.</p> <p>approx 1930 "</p>	<p>We move back into yesterday's leaguer area. Communications OK. 48 Bde had a bad night last night but this morning the road block and the bridge near it appear to be clear and there is a fair chance that the replenishment can come through. This is very necessary now as everything is short. Yesterday's fighting seems to have died down quite a lot now except for a few occasional shots at a concealed enemy gun by 414 Bty.</p> <p>Replenishment arrives with Capt. Felton in charge. Battery situation now OK. 2 RTR report enemy now shelling bridge and it looks as if replenishment echelon might have a sticky time getting back. It is decided however to silence the enemy gun and get them across. This seemed to be effective except for a few desultory shots and the echelon got through OK. The Brigade commander having visited Bur Div HQ returns about the same time with orders which send Bde HQ back to Bur Div, the 2 RTR to operate with forces in the west and the 7 Hussars to stay under command 17 Ind Div in Taungwingi area.</p> <p>Brigade HQ moves back to Bur Div HQ area near PIN CHAUNG. 7 Hussars remain on forward control and send a tank to 17 Div as their link to that formation. Bde HQ plus 2 RTR, HQ 1 W. Yorks and HQ 414 Bty leaguer in area 4 miles W of Bur Div. Forward control closed down until first light. Detachment was withdrawn from 48 Bde.</p>	
<p>14th April.</p> <p>1700 hrs.</p>	<p>We leaguer under cover in the same area. BM & OC visit Bur Div HQ for information and orders. Bur Div is moving back to MAGWE area and we are to move with the remaining regiments under command to same area this evening. WT communications normal. Hourly calls only to 7 Hussars.</p> <p>Move back towards MAGWE. On arrival we close leaguer for night. Forward control closed down until first light tomorrow.</p>	
<p>15th April.</p>	<p>Communications as for yesterday. We leaguer area E of Magwe. Bur Div HQ is in MAGWE. We still keep in touch with 7 Hussars every hour and are able to organise their replenishment for them. 2 i/c comes up from B Ech and brings F of S who reports nothing of value from his trip to Yennanyaung. Close leaguer for night same area. Forward control again closed for night.</p>	

WAR DIARY

OR

INTELLIGENCE SUMMARY.

(Erase heading not required.)

Army

Instructions regarding War Diaries and Intelligence
Summaries are contained in F. S. Regs., Vol. I.
Title pages will be prepared in manuscript.

Hour, Date, Place 1942.	Summary of Events and Information	Remarks and references
16th April.	<p>Bde HQ & 2 RTR etc dispersed same area E of Magwe. Communications - no change. During morning Bur Div report that Magwe is being attacked by the enemy from the south. General exodus from Magwe. 2 RTR and their troop of 414 Bty sent up to deal with the enemy. Infantry of Bur Div are unable to hold enemy round Magwe area so a rear guard known as MAGFORCE is formed and the remainder of the Div move N towards Yenangyaung. Bde HQ & 2 RTR (less 1 squadron with Magforce) move same direction at 1700 hours. 2000 hrs approx after crossing PIN CHAUNG arrive at leaguer area (MS 372) N of Pin Chaung. 2 RTR who are following Bde HQ are held up just N of the chaung by what appears to be a road block. This causes mild excitement throughout the night and OC 2 RTR says he is going to wait until first light to break through. WT communications OK.</p>	
17th April.	<p>Bde HQ breaks close leaguer at first light and moves into cover about 5 miles N of this new road block. Situation roughly is that a road block has developed about 2 or 3 miles N of the Pin Chaung cutting off majority of 2 RTR and some RIASC lorried transport. Also enemy troops have occupied the northern outskirts of Yenangyaung cutting off the whole of Bur Div who have just arrived into the south of the town en route from Magwe. Bur Corps HQ which has moved N beyond KAUKPADANG ask us to provide communications to them whilst the present emergency exists. Breadvan detachment despatched. Communications as per diagram dated 17.4.42. 7 Hussars under command 17 Div calling hourly during daylight. Operations commenced by 2 RTR breaking through the road block which confronts them. They return to our area. Bur Div seriously held up in Yenangyaung. Chinese LO arrives to reade area - Chinese forces are to arrive this evening. Our detachment with Bur Div HQ is doing sterling work. They are the only link from that HQ to any higher formation and consequently have been continuously on the air. They are maintaining excellent communications. Chinese under General SUN arrive late afternoon. They seem very eager for the fray. There is to be a coordinated attack first light tomorrow. We close leaguer for the night. Night communication to Corps rather difficult as they have been moved further away. Spare set at B Ech opens up on same net to act as link.</p>	

WAR DIARY

Army

Instructions regarding War Diaries and Intelligence
Summaries are contained in F. S. Regs., Vol. I.
Title pages will be prepared in manuscript.

OR
INTELLIGENCE SUMMARY.

(Erase heading not required.)

Hour, Date, Place 1942.	Summary of Events and Information.	Remarks and references to
18th April.	<p>Move from closeleaguer to same area as yesterday. Communications to Corps & B Ech improve as daylight increases - speech each way at 0800 hours. Chinese put in attack supported by 2 RTR 414 Bty and W.Yorks. Intention is to drive Japs away from areas surrounding the Pin Chaung ford to allow the almost exhausted Bur Div to get through with their transport. Attack drives enemy back quite a good way but unfortunately not far enough to clear the chaung. Bur Div report their troops exhausted and short of water. Their HQ obviously under shellfire as commander has to leave microphone twice during conversation. Corps commander & General Sun visit Bde HQ for conference with Brigadier. Corps commander decided that it is impossible to get Bur Div out of their predicament today and orders them to stay put until dawn tomorrow morning when Chinese and ourselves are to stage another attack. Communications as per 17 Apr (unchanged) working excellently during daytime on speech - difficult key above 40 miles at night. Corps commander compliments OC on work of our Signal squadron - he says 'I don't know how you fellows do it' 'It's marvellous' and so on. OC looks slightly coy. Close leaguer for night with 2 RTR (less squadron still with Bur Div). Test made by OC at 2200 hrs on 7 mc/s to B Ech 50-60 miles away - R8 key W's heavy. If communications at night get very difficult intend to use this frequency with horizontal aerial for long distances.</p>	
19th April.	<p>The operation of getting Bur Div out of Yenangyaung starts at first light. Chinese cooperating with our guns and tanks N of Pin Chaung. We hear a rumour during the morning that Kaukpadang about 20 miles N of us is being attacked by enemy. This later proves false as it turns out to be our friends the Chinese taking up positions. Operations round Pin Chaung drag out until afternoon when at last Bur Div manage to start coming through. Our squadron of tanks with them gets through but unfortunately all Bur Div soft transport as left behind including L/Cpl. Howard's breadvan which has to be burnt. And so Faba's (Bur Div) only link with the outside world goes off the air after doing a very good job. Remainder of day spent organising the withdrawal of Bur Div through our positions to the N. L/Cpl Howard plus detachment walk into the leaguer at 1900 hours looking tired but fairly cheerful. Close leaguer for night. Communications normal less link to Bur Div.</p>	

WAR DIARY

Army

OR

INTELLIGENCE SUMMARY.

(Erase heading not required,)

Instructions regarding War Diaries and Intelligence
Summaries are contained in F. S. Regs., Vol. I.
Title pages will be prepared in manuscript.

Hour, Date, Place 1942.	Summary of Events and Information	Remarks and references
20th April.	We stay all day in same area whilst Bur Div are being ferried back and reorganised. 2 RTR and guns still in same area N of chaung putting in attack with General Sun & his Chinese. WT communications normal. Close leaguer at night. Communications at night and normal frequencies difficult. 7 mc/s tried again with little success this time.	
21st April.	Communications unchanged. We stay in the same area until evening, when we move back to MS 35 E of Kaukpadang on MEIKTILA road. WT communications tonight easier because everybody is within 20 miles of one another. Close leaguer for night. Forward control closed until first light.	
22nd April.	Bde HQ and all Unit Bdes (7 Hussars having rejoined during night) find leaguer areas in vicinity & everybody settles down for a breather wash and brush up. Forward control closed. Contemplate getting Signal Office and line waggon up to Bde HQ but decide to wait on being told that we shall probably move again. Told by Commdr to bring up the SO etc. They arrive at 1600 hours. Brigadier & BM visit corps HQ and on their return we pack up to move. Forward control reopened & communications normal. We move at 1700 hours to a place 6 miles W of Meiktila where we make normal harbour for the night. Set at Bur Corps told to return - Capt Felton brings it back. Other communications normal.	
23rd April. 6m W of Meiktila.	BM & OC visit Corps to meet representative of General Stillwell. We are now under his direct command. OC arranges to listen on 7 mc/s for set at General Stillwell's HQ calling us at 0800 and 1600 hrs tomorrow. Apparently they have only one station at their HQ to run communications throughout the Chinese Army. Also arrange with Corps to listen for one of their 11 sets on 3200 kc/s from 1700 hrs onwards as they still want to keep touch with our HQ. C in C visits Bde HQ.	

Instructions regarding War Diaries and Intelligence
Summaries are contained in F. S. Regs., Vol. I.
Title pages will be prepared in manuscript.

WAR DIARY
OR
INTELLIGENCE SUMMARY.
(Erase heading, not required.)

Hour, Date, Place 1942.	Summary of Events and Information	Remarks
<p>24th April. Location unchanged.</p>	<p>Test to Chinese is unsuccessful although we hear them calling other stations. OC decides to send one of our own breadvans detachments to them if Brigadier agrees. This is arranged as Brigadier thinks it not now necessary to worry about keeping contact with Corps, and the detachment we held in reserve for them is despatched with Capt. Felton to Chinese HQ at KYAUKSE. Communications as for today's date. Brigade moved during evening to area approx 5 miles N of Meiktila and leaguered in a wood. Brigade Commander experiencing difficulty in obtaining the return of elements of our Brigade from General Sun of 38 Chinese Div.</p>	
<p>25th April. Location unchanged.</p>	<p>Communications unchanged and OK. 7 Hussars patrolling S & SW of Meiktila saw several enemy tanks. They also had a brush with some infantry and lorries and shot them up fairly effectively. We receive orders during the afternoon to revert under command Bur Corps (Our attachment to the Chinese Army was very brief) and new orders and plans are issued. B Ech and 65 Coy move over the river tomorrow. Communications OK - set at General Stillwell's HQ is told to go to Corps HQ. 1 West Yorks are given job of defending Meiktila for tonight - OC arranges for tank to go with them as link. This latter gives certain amount of trouble during night and IM is despatched in dingo to fix it.</p>	
<p>26th April. Location unchanged.</p>	<p>Communications unchanged. General policy is to hold Meiktila until tonight to allow Chinese to withdraw to railhead at Wundin and then in conjunction with 63 Bde we withdraw slowly. 7 Hussars in contact again first light 6 or 7 miles S of Meiktila. Caught an enemy column by surprise and had lots of fun. Further operations during day by 1 W.Yorks and 7 Hussars. Remainder of Bde moved back to WUNDIN area at dusk, to be followed later by 7 Hussars and 1 W.Yorks. The latter arrived in leaguer about midnight with some wounded. Not a very good night tonight - raining, no moon and a well-known character in 2 RTR gets bitten by a snake.</p>	

WAR DIARY

Army

Instructions regarding War Diaries and Intelligence
Summaries are contained in F. S. Regs., Vol. I.
Title pages will be prepared in manuscript.

OR
INTELLIGENCE SUMMARY.

(Erase heading not required.)

Hour, Date, Place	Summary of Events and Information	Remarks
1943.		
<p>27th April. Location Paungi Chan WUNDWIN.</p>	<p>Communications unchanged. We receive orders from 17 Ind Div re withdrawal although as far as we know we are under command Corps. 2 RTR are sent forward to protect 63 Bde still withdrawing. 2 RTR unhappy during day as the enemy use ground effectively and don't give them much sport. They keep the 63 Bde under their protection however. Towards evening 7 Hussars are told to get their ticket punching belts on and ferry out 63 Bde on their tanks. 2 RTR do rear guard. 7 Hussars do some remarkable ferrying with their tanks - London Transport Board isn't in it. Snag about it is that these coloured gents will hang on to the aerial rod for precarious support and communications therefore suffer. Bde moves after the 63 Bde and 7 Hussars are through leaving 2 RTR as rearguard. We travel all night towards the river crossing (AVA Bridge).</p>	
<p>28th April.</p>	<p>After travelling all night we cross the AVA Bridge at 0800 hours and continue on to new area N of ONDAW, where we harbour for the day and rest. Communications unchanged. Bde visited by Army commander and BGS during evening.</p>	
<p>29th April. Location N of ONDAW.</p>	<p>2 RTR arrive in area during morning. 7 Hussars stay other side of river at KYAUKSE with 63 Bde as they seem to be dealing quite happily with situation. Communications OK. See diagram of today's date.</p>	
<p>30th April. Location N of ONDAW.</p>	<p>7 Hussars rejoined Bde first light. 38 (Chinese) Div are holding AVA Bridge area and General Sun again obtains 414 Bty guns to support him. We are now endeavouring to hold the line of the River Irrawaddy - during day orders received to send squadron to guard eastern flank. (1 squadron - 40 miles to patrol - some job!). Capt. Felton at Corps HQ told to go to Army HQ at Shwebo.</p>	

WAR DIARY

OR

INTELLIGENCE SUMMARY.

(Erase heading not required.)

Army

Instructions regarding War Diaries and Intelligence
Summaries are contained in F. S. Regs., Vol. I.
Title pages will be prepared in manuscript.

orig
3044

Hour, Date, Place 1942.	Summary of Events and Information	Remarks and
1st May.	<p>Brigade commander & OC visit Army HQ. OC visits set with Capt. Felton whilst there. Brigade commander learns at Corps that the Squadron intended for the eastern flank Has been switched to MONYWA to counter a threat in Bur Div area. 414 return to Brigade area and command. We move during night to area 4 miles W of YE-U - 7 Hussars and 2 RTR etc follow. We are now in Bur Div zone of operations.</p>	
2nd May.	<p>At dawn Brigade moved 19 miles nearer MONYWA. 7 Hussars move ahead to join up with their squadron in that area. Brigadier & OC visit HQ of Bur Corps in early morning taking with them Cutler's WT detachment. Capt. Felton at Army ordered to proceed to Bur Corps with his detachment and on arrival, to tell the detachment there to report to this HQ. We move again during day nearer MONYWA to BUDALIN. Rear Bde HQ formed under Capt. Hough HQ Squadron from 'Soft' vehicles, and sent back to our previous location. Capt Felton's detachment has now arrived at Corps and Cutler's detachment reports to Rear Bde as their link. See diagram of today's date.</p>	
3rd May. Location unchanged.	<p>2 RTR take over from 7 Hussars in forward areas. Bur Div now moving out of Monywa after being out off once again - they all are very tired. In the evening 7 Hussars once again do 'Bus Coy' stuff with their tanks, ferrying Bur Div back to Ye-u area. As there appears to be some doubt about our being able to get our tanks over the Chindwin when we finally withdraw, a Recce is sent out to find a way over.</p>	
4th May. Location Unchanged.	<p>We now cover remainder of Bur Div's withdrawal to Ye-u. Later in day we finally get orders concerning our own Troops and Bde withdraws to within 2 miles of Ye-u, behind Bur Div's defensive position. 7 Hussars go on to KADUMA. Communications OK and unchanged.</p>	
5th May. Location unchanged.	<p>2 RTR patrolling S towards canal. Bur Div withdraws to Kaduma during day. We are to follow covering them. Communications unchanged except that the set with Capt Felton has now been transferred from Corps to Bur Div. Bde and units in Kaduma by midnight. Close leaguer for the night. We don't like this place much as we are entirely encircled by forest.</p>	

WAR DIARY

Army

Instructions regarding War Diaries and Intelligence
Summaries are contained in F. S. Regs., Vol. I.
Title pages will be prepared in manuscript.

OR
INTELLIGENCE SUMMARY.

(Erase heading not required.)

Hour, Date, Place	Summary of Events and Information	Remarks
1942.		
6th May. Location KADUMA area.	We receive orders to move to SHWEGIN on the Chindwin tonight. During day 2 RTR have patrols out S towards Ye-u and 7 Hussars out on eastern flank. No contact - quiet day. At 1800 hrs we start our 70 miles trek to the river, and travel all night over the worst track yet encountered. Capt Felton, who had injured his leg was sent on ahead during the day in his own truck with two batmen to look after him. He is unable to walk and OC wishes to get him over river safely.	
7th May.	At dawn we reached PYINGAING - we have had a pretty poor night - the road was frightful and for most of the journey we were slowed down to the pace of a mule train blocking our path. We are to continue on to Shwegin by daylight - moving much faster now, although the road is still tricky. Several Bde vehicles are lost over the hill-side including OC's staff car. After travelling all night & day, without even pausing for meals, we reach Shwegin area at approx 1600 hrs, where we leaguer in the forest. Advance party is sent to ferry to arrange for the ferrying of the Bde - everybody's hopes high that we'll get our tanks and vehicles over. The ACV must be ferried somehow. Communications unchanged.	
8th May.	Brigade commander visits ferry, learns that ferry boats only work at night although no evidence of enemy aircraft. Despite all efforts at speeding up the ferrying of personnel and transport, it looks extremely unlikely that any of the tanks and lorries will get across. Our sunny dispositions marred a little at this news. Later we hear that we are scheduled to cross (probably less our transport) on night of 9/10 May. 7 Hussars rejoin Bde this evening. Communications unchanged.	
9th May.	L/Cpl. Howards breadvan has crossed ferry with Bur Corps and is established at KALEWA. We send Cutler's breadvan to the ferry to keep us informed. Orders received that Bde (less 7 Hussars, again rear guard) will cross on night 9/10 with 23 special vehicles. All other vehicles to be destroyed, less a squadron from each Regiment to do rear guard. We get on with mournful job of destroying our transport - keeping 4 wheeled drive vehicles in case more than 23 may be taken. All valuable gear, including WT sets not working, piled onto F of S charging lorry. WT control is taken over on B Ech breadvan and <u>ACV* is destroyed</u> . Orders received later that our crossing tonight has now been postponed to allow 63 Bde to get over to Kalewa.	

Instructions regarding War Diaries and Intelligence
Summaries are contained in F. S. Regs., Vol. I.
Title pages will be prepared in manuscript.

WAR DIARY

OR

INTELLIGENCE SUMMARY.

(Erase heading not required,)

Hour, Date, Place	Summary of Events and Information	Remarks and
1942.		
9th May (cont)	<p>The whole Bde move down to within 2 miles of ferry. Orders received just after midnight that 2 RTR were to move down the remaining 10 miles to the ferry and be ready to cross.</p>	
10th May	<p>* The ACV deserves better obituary than this - it has served the Brigade since April 1941 throughout many operations, and before that it graced 7 Armoured Div HQrs as ACV2 for a considerable period. Mechanically and tactically it was an excellent vehicle, well suited for the job. We were sure it could have got across, with a spot of luck, and gone all the way to India. Everybody was sad at losing it, as it was a symbol of efficient control to the whole Brigade.</p>	
10th May.	<p>2 RTR cross at approx midnight. Communications as per diagram of todays date. Contact with Kalewa and the ferry is still being maintained and these are the only sets in the whole force functioning except Army's links to India. Sounds of trouble down at the ferry started at first light. Brigade GIII (Capt Tyler) who was on the set at ferry reported "Things are getting warm." A detachment of enemy were taking up positions on the top of the hills above the landing stage and were being opposed by 48 Bde, helped by the 7 Hussars.</p> <p>This action continued all day and eventually the enemy brought the landing stage under mortar fire. Orders were then received that all vehicles would be destroyed and all personnel on this side of the river would march during tonight to a spot on the bank immediately opposite Kalewa, called KAING, where ferries would pick them up and take them over at first light. This was 6 miles as the crow flies, but about double that distance by the goat-track over the hills.</p> <p>All our equipment and vehicles still remaining to us were destroyed. Personnel formed into sections for marching and with the rest of the Brigade we set off. The march was forced over extremely bad going, so that men fell out to take necessary rests individually. The sections therefore got broken up amongst the confused mass of mixed bodies.</p>	
1900 hours.		

WAR DIARY

OR

INTELLIGENCE SUMMARY.

(Erase headings not required.)

Army

Instructions regarding War Diaries and Intelligence
Summaries are contained in F. S. Regs., Vol. I.
Title pages will be prepared in manuscript.

Hour, Date, Place 1942.	Summary of Events and Information	Remarks
<p>11th May. 0300 hrs.</p> <p> First light.</p>	<p>Halted at top of what was believed to be the last hill before going down to the river bank. Everyone bedded down for a sleep until first light. All units completely mixed up with one another.</p> <p>Started off on last two miles. Ferry boats working constantly to and fro taking parties. Continual tea was being brewed up by the rest camp personnel in Kalewa. Bde assembled in a camp area, where a meal was fixed up and tender feet were bathed. All our starters arrived. How they avoided breaking a few necks down ravines in the night will never be known. Order received that we would vacate area by midnight. As much transport as possible would be made available. Afternoon spent waiting for this. By evening a certain amount of it has arrived, and it is decided to ferry troops to the next rest camp at MS 27. First party are carried 10 miles and dropped to walk on a little. Meanwhile more transport arrived and finally all were picked up and dropped a mile and a half short of destination. All slept by the side of the road.</p>	
<p>12th May.</p> <p> 1600 hours.</p>	<p>Moved half a mile down the road to a rest camp where tea and provisions were produced for breakfast. 0900 hours. Marched a mile further on and joined up with the main body of Brigade. Some of the men's feet are in a bad state from the first march. Members of the medical section attached to Brigade HQ are carrying their first aid haversacks and the MO deals round plaster where necessary. Our next destination is YESAGYO, 15 miles along the road. The Brigadier decides that we will rest until 1600 hours and then march on. Men lie round in huts for the day. We now eat and prepare meals in four sections, for convenience sake.</p> <p>Start marching. We now go on normal route march style with halts at regular intervals, but owing to the bad state of some feet there are a number of stragglers. Camp area allotted to us is a 'pongi chaun' on top of a cliff over the river. An advance party of sick and halt has been sent in, and tins of steaming tea are waiting for us. All our stragglers are in by 2230 hours.</p>	
<p>13th May.</p>	<p>Most people go down to the river to bathe during the morning. Further patching up of blistered feet. We are to move to KAMPUT, 25 miles further on today. Lorries are provided for this move, for which many grateful sighs are sent up. Reach new camp about 2000 hours and again tea is ready.</p>	

WAR DIARY

OR

INTELLIGENCE SUMMARY.

(Erase heading not required,)

Army

Instructions regarding War Diaries and Intelligence
Summaries are contained in F. S. Regs., Vol. I.
Title pages will be prepared in manuscript.

Hour, Date, Place	Summary of Events and Information	Remarks
1942.		
14th May.	<p>Morning spent resting. Lorries appeared to take us onto TAMU. Arrived rest camp approx 2100 hours where a meal was waiting. The usual dear old bully stew, but we are lucky to have had it cooked for us. After the meal we carry on in our lorries to our own camp area, which is in the middle of a wood. People stumble about the undergrowth trying to find one another.</p>	
15th May.	<p>In the morning the sick and the halt were sent on to our next stop, LOKCHAD, to have a meal ready when the remainder walk over this afternoon. This march was described to us as equivalent to a pleasant English afternoon walk, but the ups were very much more up and the downs more down when we came to do it. Lokchad was reached about 2000 hours and the camp was by the side of a stream in a deep ravine, which was suffering badly as an overcrowded temporary camp.</p>	
16th May.	<p>Group of 27 enemy bombers passed over the camp this morning. Later heard that these paid their attention to IMPHAL. RIASC transport appeared to take us to Imphal. Very good midday meal was provided for us at the staging camp at PALEL. We were then changed on to a new party of lorries who were to carry us the rest of the way. We passed through Imphal in the dark but could see a lot of damage in the bazaar area from the morning's raid. Two miles out the lorry carrying a party under SQMS Marks went off the road, which was banked up to a height of about six feet, and fell on its side. There were no casualties apart from bruises to many and slight concussion to L/Cpl. Holbrough. The party stayed by their truck until the main body arrived at the camp area (MS 118 MANIPUR ROAD), when 2/Lt Squier took a truck back to pick them up. All finally arrived in camp about midnight.</p>	
17th May.	<p>Woke up to find ourselves in a rest camp with an ordnance dump attached. SQMS drew up new shirts, shorts, socks, towels and mosquito nets to help fit up everybody. Most peoples few clothes (average of one suit only per man) are definitely showing signs of wear, tear and lack of dhobi facilities. Heavy rain most of the day - with no shelter except the bushes and a groundsheet this became rather miserable.</p>	

WAR DIARY

Army

OR

INTELLIGENCE SUMMARY.

(Erase heading not required.)

Instructions regarding War Diaries and Intelligence
Summaries are contained in F. S. Regs., Vol. I.
Title pages will be prepared in manuscript.

Hour, Date, Place 1942.	Summary of Events and Information	Remarks
18th May. Location unchanged.	A few more items of clothing were gathered in from the ordnance. Everyone now has either a ground sheet or a gas cape to keep out the rain, which is continuing. An advance party was sent down to look over a new camp site at MS 108. We managed to find six tents between Brigade HQ and ourselves for them to put up there ready for us.	
19th May.	We are still cooking by small sections, and it is interesting to see how the various groups react. Some do very well for themselves, others are a little helpless. The effect of the present wet weather coupled with the strain of the last few weeks is showing itself. The MO is trying hard to cope with a long string of upset stomachs, septic sores and feverish headaches. He is trying to arrange evacuation to railhead for the sick, but transport seems scarce. (Still being used to bring people out of the forward areas.). Move in the afternoon to new camp at MS 108. By use of our tents, tarpaulins and tent covers we manage to get everybody under some sort of cover.	
20th May.	MO manages to arrange evacuation for some of our sick, so we send off eleven men. There are others who will probably have to go soon. Time spent in digging latrines and improving shelters.	
21st May.	A limited amount of canteen stores came down from camp at MS 118. Half a bottle of beer and ten cigarettes per man (oh heaven-sent gift!). Have now got the squadron cooks catering for the whole party. Most peoples stomachs seem to be in a bad state now. Rumours heard of some mail in the area.	
22nd May.	The mail arrives, bags and bags of it. The effect on everybody's spirits is tremendous. Some receive parcels containing cigarettes, which help out the shortage a little. Considerable speculation as to our immediate future. Are we going back to India straight away to refit or what?	

WAR DIARY

Army

Instructions regarding War Diaries and Intelligence

Summaries are contained in F. S. Regs., Vol. I.

Title pages will be prepared in manuscript.

OR
INTELLIGENCE SUMMARY.

(Erase heading not required.)

Hour, Date, Place 1942.	Summary of Events and Information	Remarks and
23rd May. Location unchanged.	Five more men evacuated sick this morning with the usual complaints, some fever and some probable dysentery. Managed to get another packet of cigarettes per man from the canteen at MS 118. Still raining hard, but we are better off than the regiments who are on the side of a hill and always get streams running through their tents after every shower. This place is now becoming known among us as 'the hump on the hillside'. Chaps employed in building loose stone pathways about the camp, and digging drainage channels to try and keep down the mud.	
24th May.	Six more men evacuated sick this morning - our squadron is evaporating alarmingly. Were told that General Wavell (C in C India) would probably visit us some time today. No ceremony arranged. Divine service held on the hillside this afternoon. General Wavell arrived just as a number of people were having an afternoon bath in the stream. Brigadier conducted him round the regiments first while we hastily collected all our old bodies. Had just got them arranged with fully clothed personnel in front and those with towels round their middles at the back when he came back to see us. On his request he was introduced to all officers and then gave a short, very personal, talk to everybody. Explained the difficulties of the rushed Q job to receive us in Assam and hence the lack of comforts and amenities, complimented us for our work during the campaign and at the same time intimated that the experience gained would be called upon at a future date. The visit left everyone with a nice pleasant feeling of satisfaction, that we had been thought about and appreciated.	
25th May.	Great excitement this morning, because 2 RTR left by lorry en route for railhead. Their ultimate destination is RANCHI, which is vaguely believed to be about 200 miles N of Calcutta. The rest of us are going to move when the 2 RTR transport arrives back, or when any more transport becomes available. More mail is arriving, a lot of it being Christmas mailed addressed to Egypt, which didn't arrive before we left. Anyway it is very good to get.	
26th May.	Still waiting patiently for the transport to railhead. OC decided that a little exercise would be a good thing, so 2 nd Lt Squier conducted the party on a short ramble round the adjoining hills. The day was warm and bright with a good breeze on the hills, and the walk was very pleasant. Orders received, that we were to be ready to move off to railhead at crack of dawn tomorrow. We shall not be sorry to leave this extremely damp, feverish part of the country.	

WAR DIARY

OR

INTELLIGENCE SUMMARY.

(Erase heading not required.)

Army

Instructions regarding War Diaries and Intelligence
Summaries are contained in F. S. Regs., Vol. I.
Title pages will be prepared in manuscript.

Hour, Date, Place	Summary of Events and Information	Remarks
1942.		
27th May.	<p>Lorries arrive at 0630 hours to take us to DIMAPUR. Move off together with LRS, OFP, Recovery Section, 414 Bty and 95 A/Tanks and 13 LFA. Haversack ration carried in lieu of midday meal. One lorry has trouble almost immediately and 2/Lt Squier is left with it to come along as soon as it is fixed. Halted at the halfway house check gates at midday to wait to go through. Moved on at 1400 hours. Arrived railway yard MANIPUR ROAD station approx 1930 hours and hot meal was ready from RIASC. Moved round into rest camp and found more hot tea waiting for us. OC (who is party commander for all units present) enquired about trains and found there was one going out tonight. Party slept for a couple of hours before train came in and 2/Lt Squier arrived with laggard lorry. Train was composed of very grimy goods waggons, and everyone bedded down as well as possible. En route by 0300 hours after loading a wagon full of rations.</p>	
28th May.	<p>Train moved in fits and starts during the night. Stopped during morning for meal from RIASC supply detachment. There are some sick on board who need evacuating. Arrive LUMDING about 1700 hours. Further meal obtained and Major Arundel, commanding Bde LFA rang up the local CCS and asked for ambulances. These arrive and, amongst others, five of our people are evacuated. OC is not only having to look after the BOR's but also a large detachment of Indian ranks who occupy the front half of the train.</p>	
29th May.	<p>Reached the ferry over the Brahmaputra at approx 0830 hours. Unload everyone plus our store of rations and shipped them all on to the boat. The boat pushed off, travelled threequarters of the way across and then dropped anchor. Two and a half hours passed and we watched the other ferries ploughing to and fro. The OC then got tired of waiting and after considerable remonstrations with the serang went ashore by country boat and within another hour we all disembarked. We had a meal on the railway station and got aboard the new train. We did have some carriages this time, but it was still narrow gauge.</p>	
30th May.	<p>Arrived at PARBATIPUR during the morning and changed trains again. This time we are on normal broad gauge line and we are comparatively comfortable. RIASC give us a meal while we are changing. Our men are getting very expert at running up to the engine at short stops and brewing tea in petrol tins by begging water from the engine driver.</p>	

WAR DIARY

Army

OR

INTELLIGENCE SUMMARY.

(Erase heading not required.)

Instructions regarding War Diaries and Intelligence
Summaries are contained in F. S. Regs., Vol. I.
Title pages will be prepared in manuscript.

Hour, Date, Place	Summary of Events and Information	Remarks
31st May.	<p>Arrived BARKHANA in the early morning and had a meal. Troops received tea and cigarettes from a canteen. Push on during the day in the usual big stop, little go fashion and have our evening meal at ASONSOL. We have to wake the supply staff and turn them out of bed to prepare the meal, because in spite of most careful telegraphs sent ahead at each stop, nobody ever seems to know that we are coming. We had to evacuate two more men here and there are some more who look as though they will soon have to go.</p>	

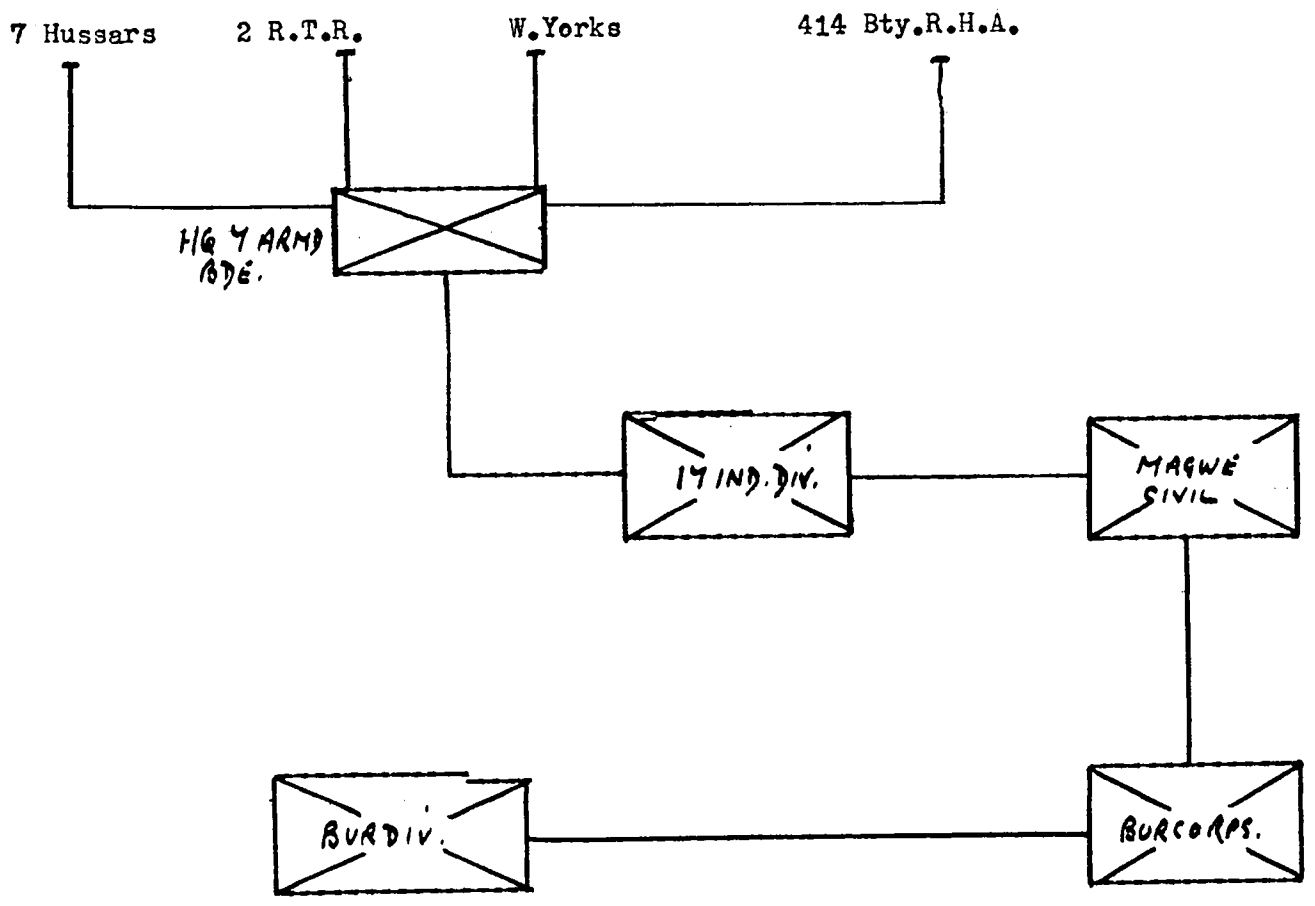
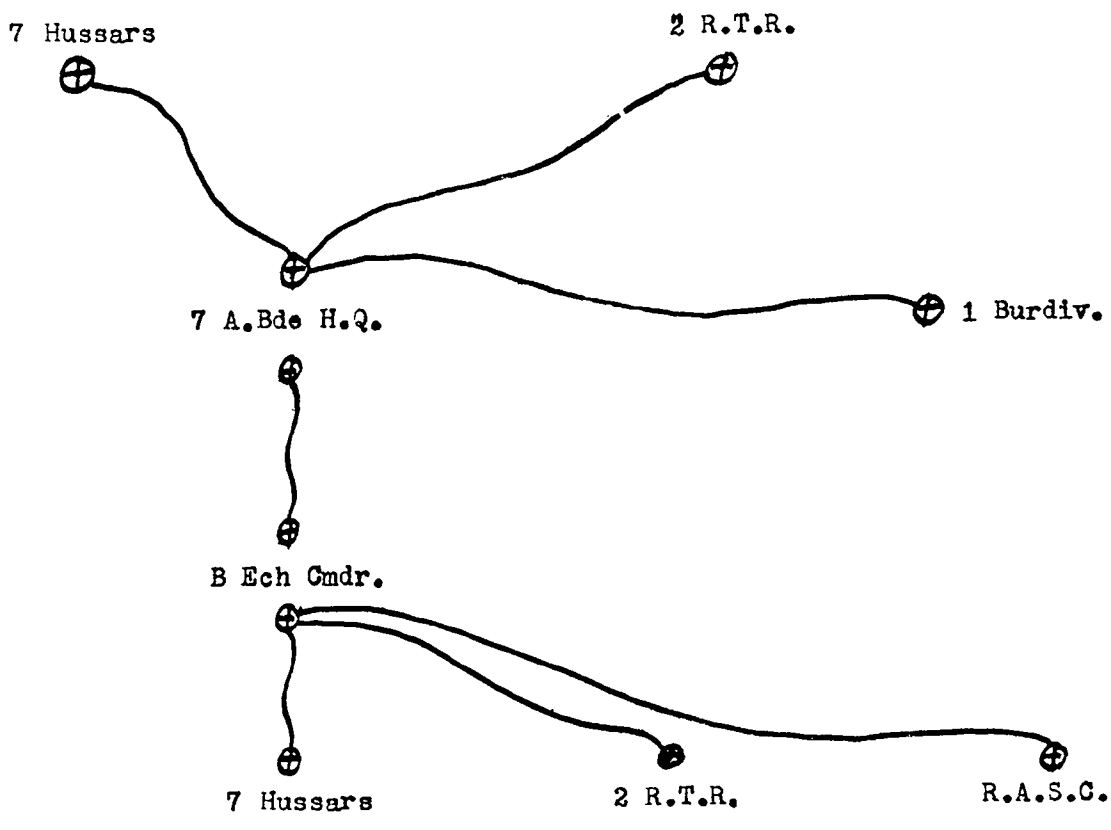

7th Armd. Bde Group Communications
as at 1700 hrs 10th April.42

Appendix "B"

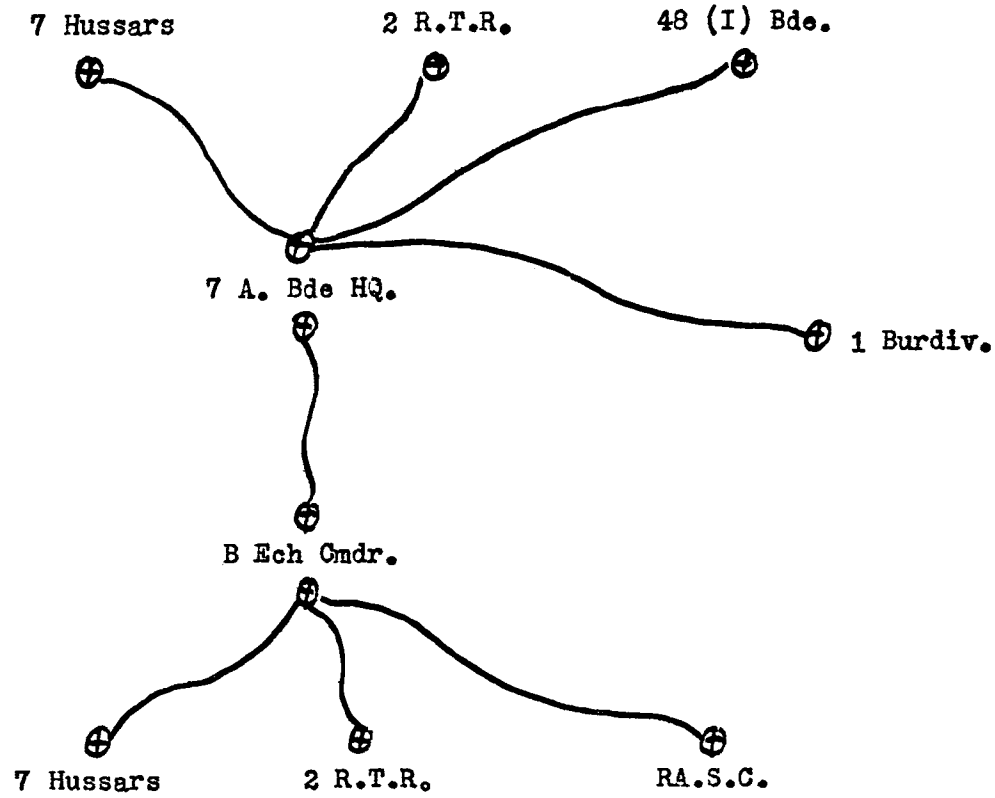

7th Armd. Bde. Group Communications
as at 1600 hrs 11th April. 42

Appendix "C"

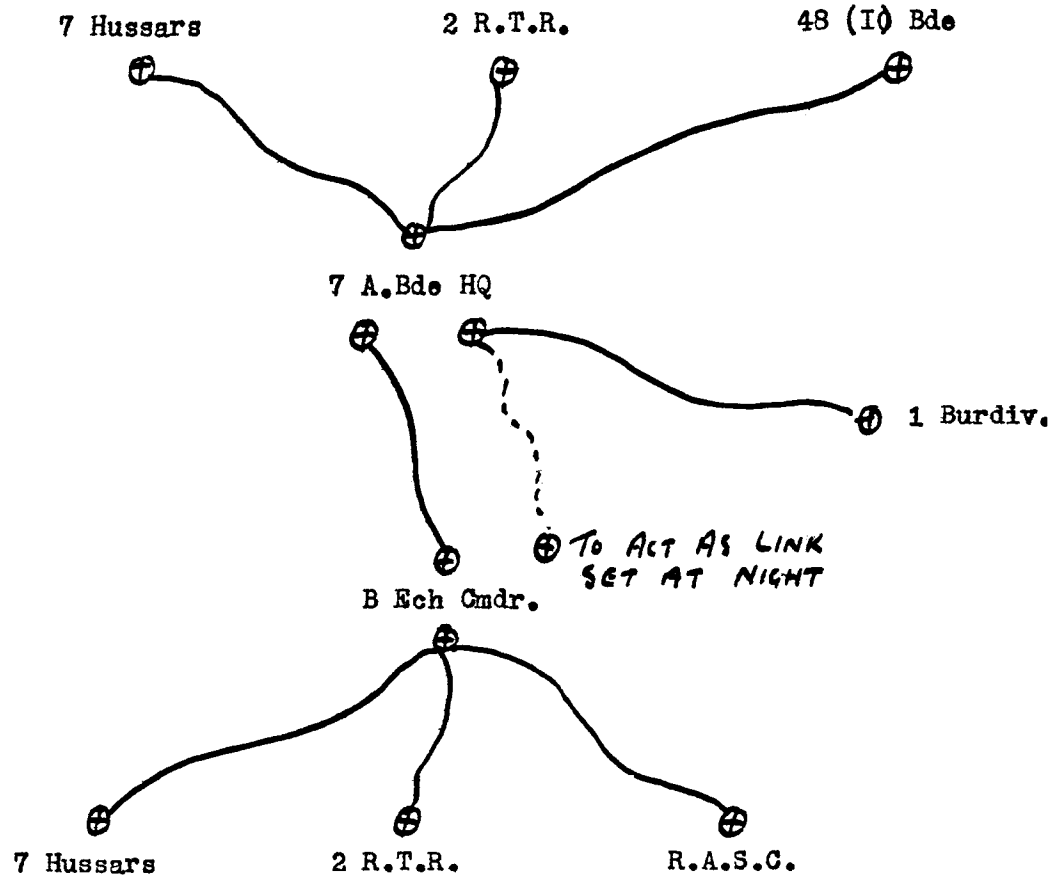

7th Armd. Bde Group Communications
as at 0001 hrs 17th April.42

Appendix "D"

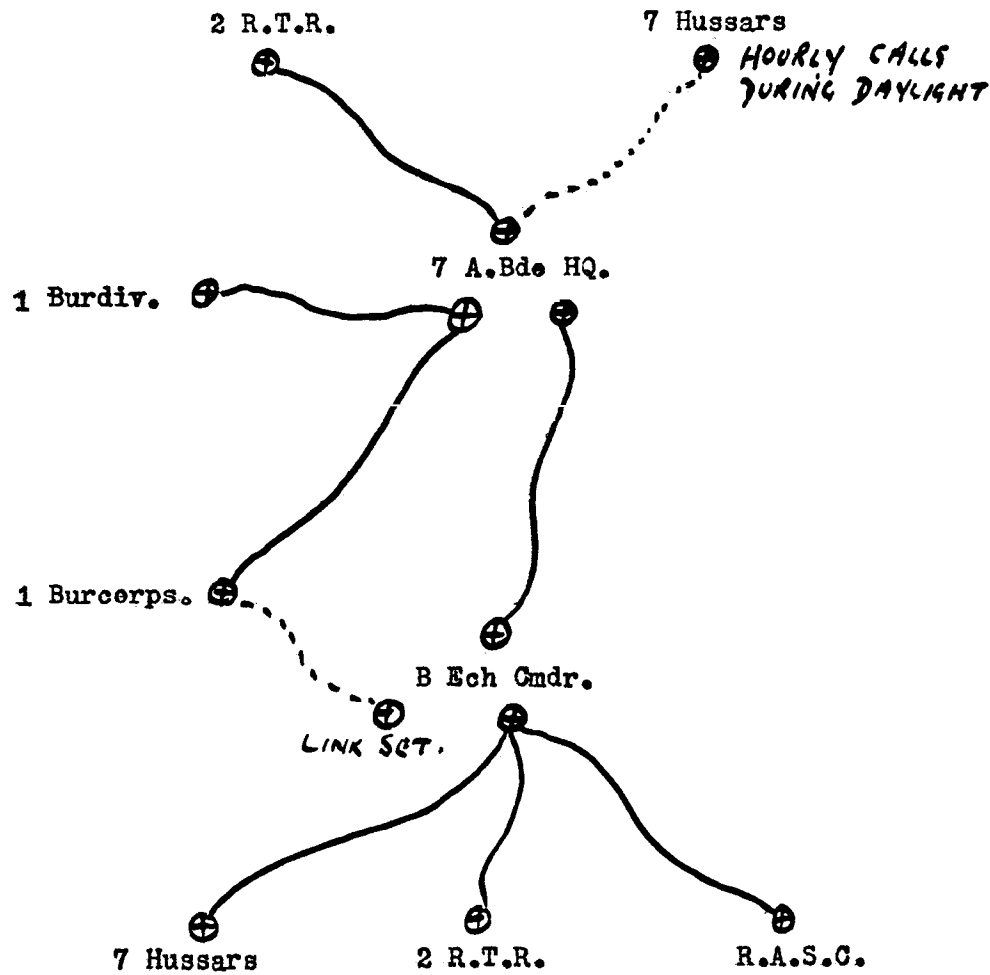

7th Armd. Bde. Communications
as on 24th April.42

Appendix "E"

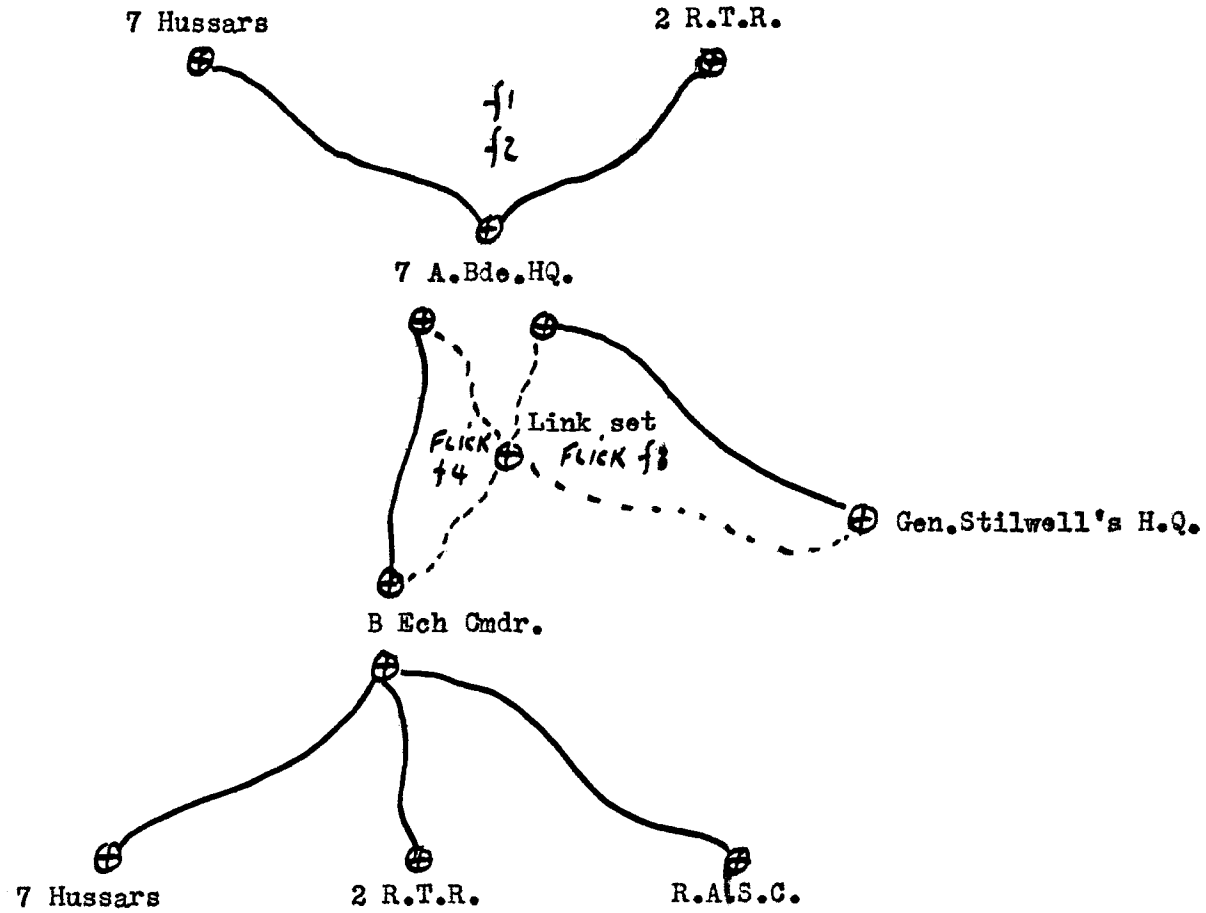

Note:- Ranges to rear now over 70 miles and link set necessary at night.

Communications 7th Armd. Bde Group
as on 30th April.42

Appendix "F"

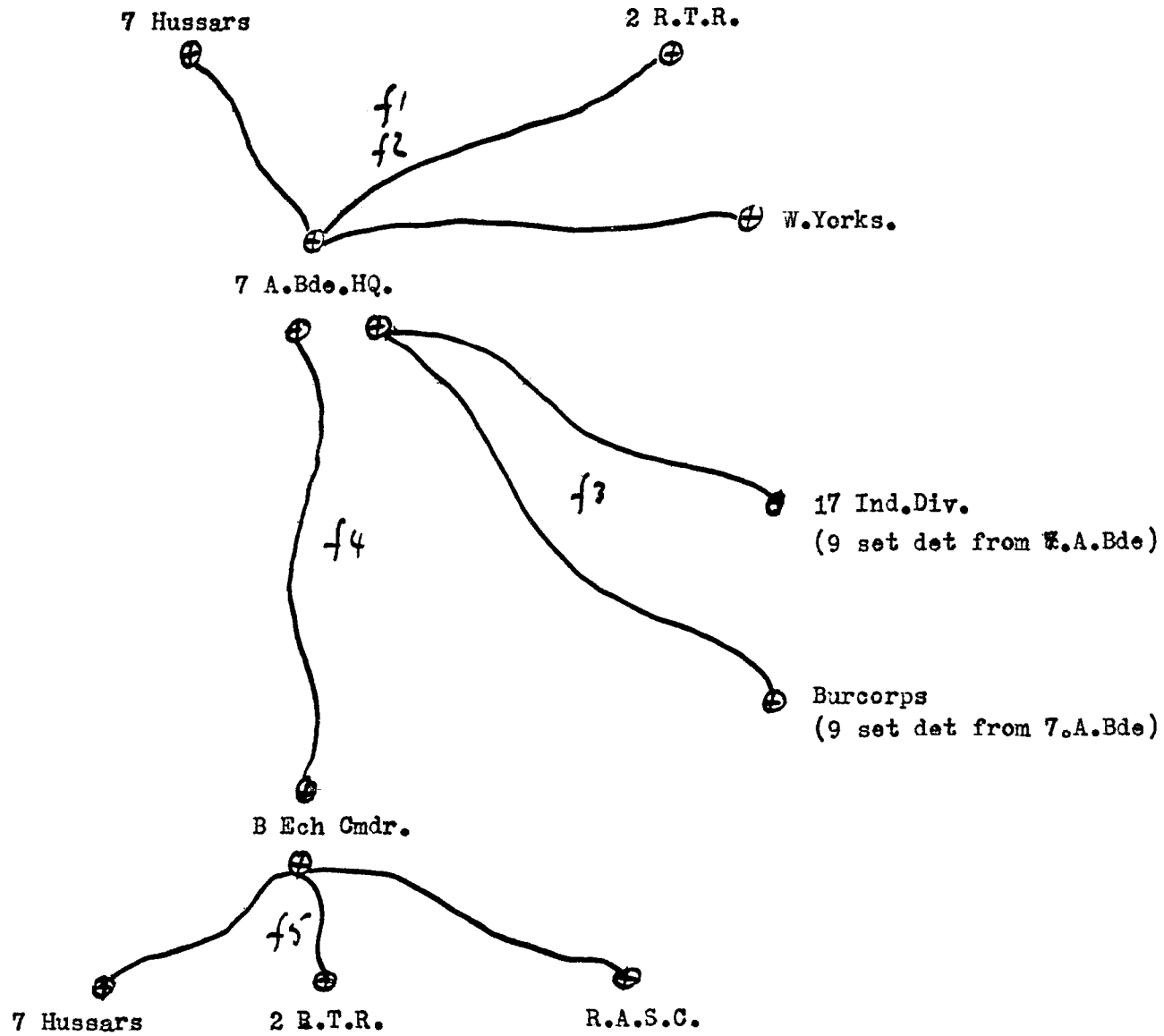

Communications 7th Armd. Bde Group
as on 2nd May.42.

Appendix  'A'

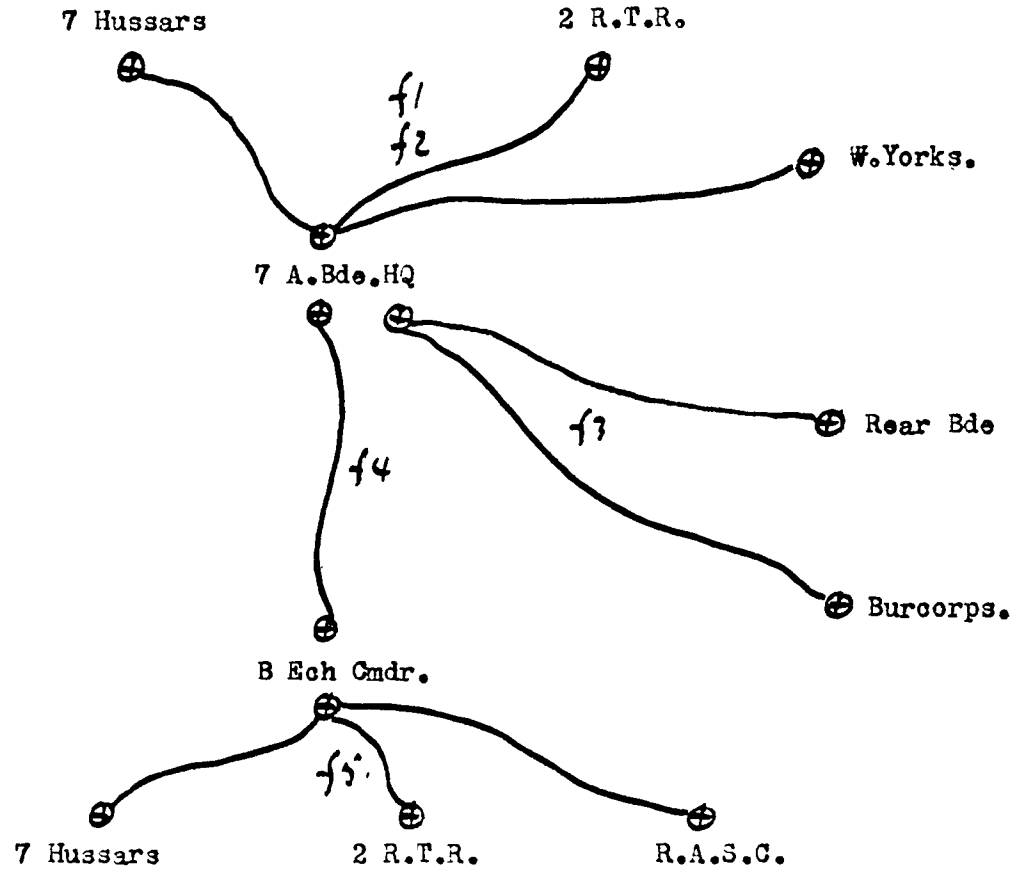

Communications 7th Armd. Bde Group
on 10th May.42.

Appendix ~~map~~ "B"

